

Home Project

Project Cost Estimator

Materials Description	Quantity	Cost
Posts (usually 125mm x 75mm)		
Rails (75mm x 50mm)		
Palings (100mm and/or 150mm wide)		
Concrete Mix		
Galvanised Nails:		
40mm x 2mm flat head		
50mm x 2.8mm flat head		
75mm x 3.75mm bullet head		
Scrap timber for bracing & stakes		
Timber Fence Finish		
Equipment		
String Line		
Spirit Level or Post Level		
Spade or Post Hole Digger		
Hammer		
Measuring Tape		
Circular Saw or Hand Saw		
Chisel Set		
Paint Brush		
Total		

All these materials you need for this job are available at Magnet Mart, your home improvement warehouse.

Build a Fence



- Easy to follow step-by-step guide
- Important and handy tips
- Materials check list
- Project Cost Estimator

Before you start, please read through this pamphlet carefully and estimate and assemble all the materials you will need for the project and gather your tools and equipment together. Refer to the checklist and estimating form on the back panel of the pamphlet to assist in this preparation.

YOU CAN – Build a Fence

Economical Timber Fencing

This brochure shows you how to build a long-lasting, economical timber fence with a minimum of fuss. Timber fences provide privacy, shelter and security for your family and pets, separating your property from your neighbour's or simply creating a divided space within your yard. With a little DIY skill and help from Magnet Mart, you can build a fence to last.

1. Laying Out the Fenceline

- If the fence is to delineate your property boundary, it is a good idea to ensure that the existing fence line is actually on the correct boundary. If you have any doubts, seek the assistance of your local building authorities before you replace the fence. Note that you may be able to share the costs of a boundary fence with your neighbour, depending on local council regulations.
- Once you are satisfied with the line of the fence, you can lay out the posts as explained below.

2. Setting the Posts

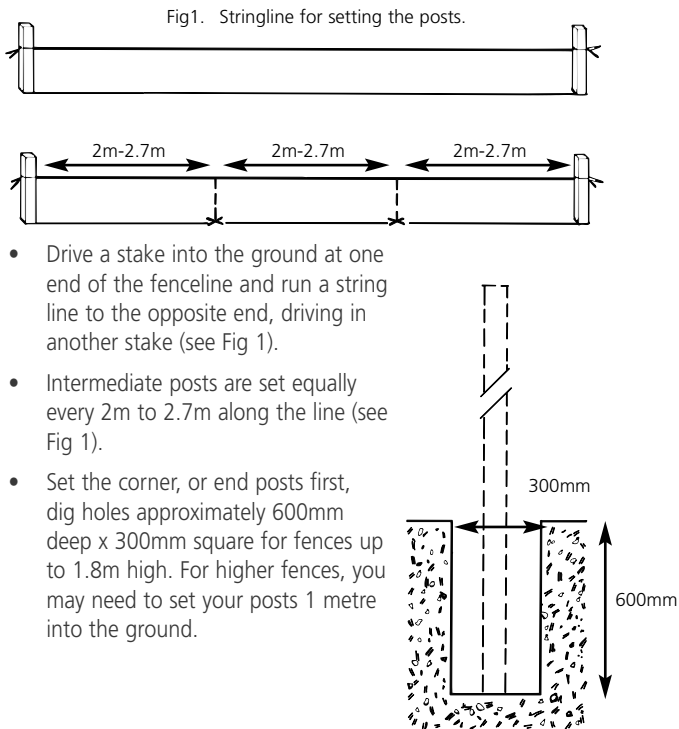

- Drive a stake into the ground at one end of the fenceline and run a string line to the opposite end, driving in another stake (see Fig 1).
- Intermediate posts are set equally every 2m to 2.7m along the line (see Fig 1).
- Set the corner, or end posts first, dig holes approximately 600mm deep x 300mm square for fences up to 1.8m high. For higher fences, you may need to set your posts 1 metre into the ground.

- Stand the post in the hole, attaching temporary bracing to hold it vertical and straight to the line. Use a spirit level or post level to check the post (see Fig 2).

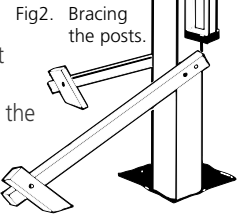

- Mix sufficient concrete to fill the post hole according to the manufacturer's instructions, fill the hole and smooth the surface, angling the concrete down from the sides of the post for drainage (see Fig 3).

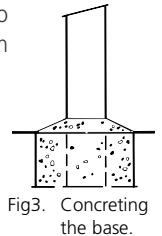

- Stretch a string line between the top of the two end posts (see Fig 4), it is a good idea to stretch a second line about mid-way down the height of the posts. Now set the intermediate posts every 2 to 2.7 metres using the procedure outlined above. Ensure the intermediate posts are level with the string lines and vertical (see Fig 5).

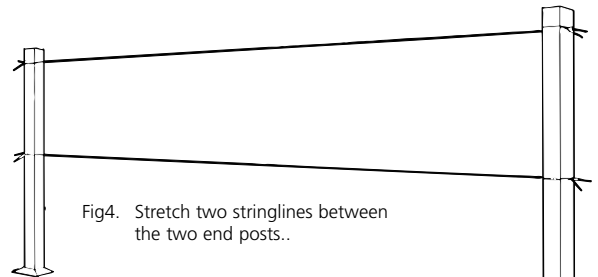

- You can fit two or three rails to the posts - a three rail fence is advisable for taller fences or where you may need an extra strong fence. Otherwise, a two rail fence is usually adequate up to 1.5 metres high.

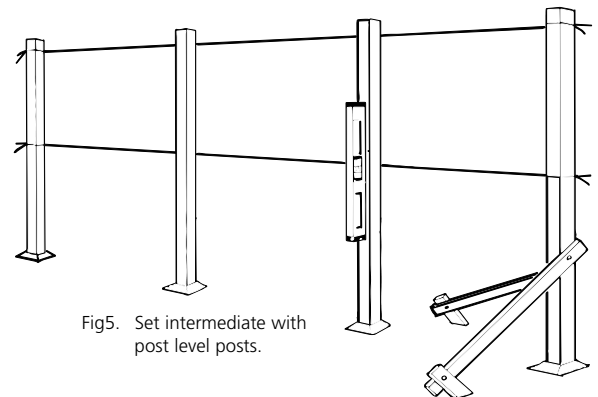

- Set the bottom rail approximately 300mm up from ground level and the top rail at a minimum of 75mm from the top of the posts (see Fig 6).
- Mark out the depth of the rail and cut notches in the posts for the rails (see Fig 7) using a saw to cut to the depth line and chisel to cut out the waste.
- Fix the rails into position and nail to the posts using 75mm x 3.75mm galvanised bullet head nails, ensure that joints are butted together in the centre of a post (see Fig 8). Stagger joints in the rails as shown in Fig 9.
- If you wish, fix a 150mm x 25mm hardwood board (a 'plinth') to the bottom of the fence, using a string line to make sure the plinth is straight. The plinth will assist in keeping the palings straight (see Fig 10). This step is optional.

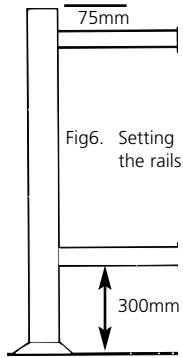

Fig7. Cut notch in the post for the rails.

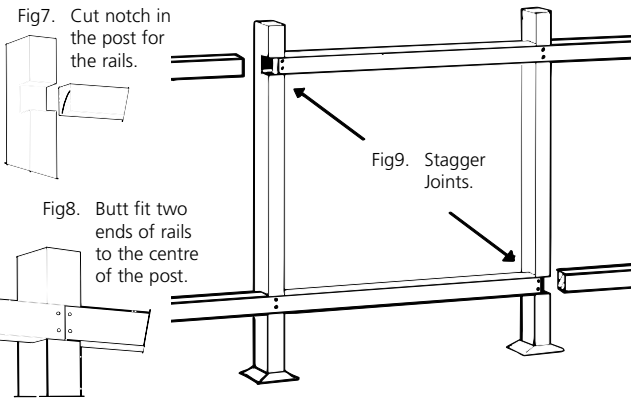

Fig8. Butt fit two ends of rails to the centre of the post.

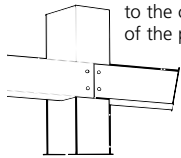

Fig9. Stagger Joints.

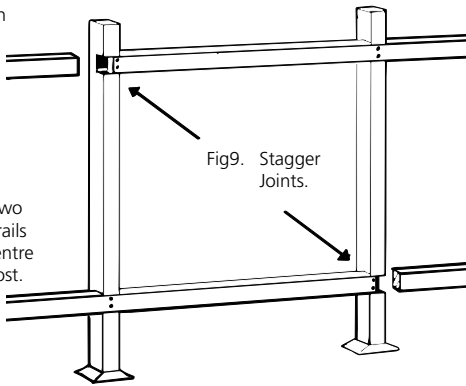
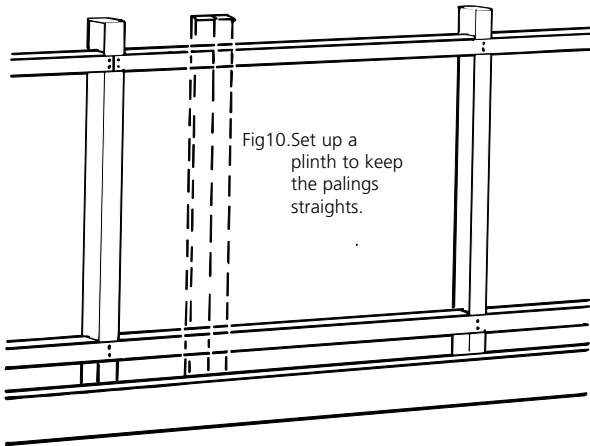

Fig10. Set up a plinth to keep the palings straight.



4. Fixing Palings

Butt Fixed Palings

- If you choose to simply butt the palings across the fence, commence at one end by first ensuring the paling is vertical (use a spirit level) and fixing it using two 40mm x 2mm galvanised nails to each rail.
- Butt the next paling against the first, ensuring it is vertical and fix to the rails. Proceed in this manner along the fence, periodically checking that the palings are vertical (see Fig 11).

Fig11 Butt fixing the palings.

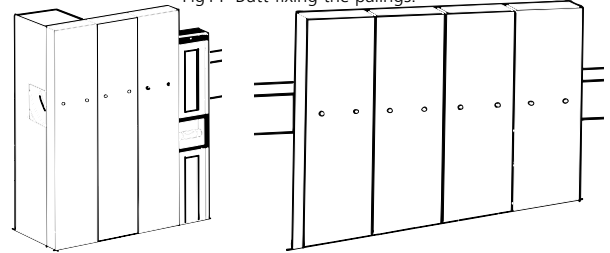

Overlapping Palings

- The best way to overlap palings is to use two different widths of paling, the first layer is made from 150mm wide palings while the covering palings are 100mm wide.
- First, fix the 150mm wide palings to the fence using two 40mm x 2mm galvanised nails in each rail, leaving a 50mm gap between each paling (see Fig 12). Ensure the palings are vertical as you go, checking with a spirit level.
- Now fix the 100mm palings over the spaces, overlapping the first palings by 25mm on each side (see Fig 13). Fix the top palings using 50mm x 2.8mm galvanised nails driven into the bottom palings, but not through them (see Fig 13). Ensuring the nails do not go through the bottom palings will reduce splitting as the timber shrinks.

Fig12 Leave 50mm gap between palings.

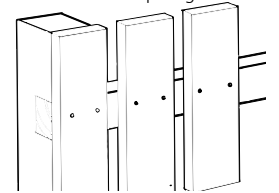
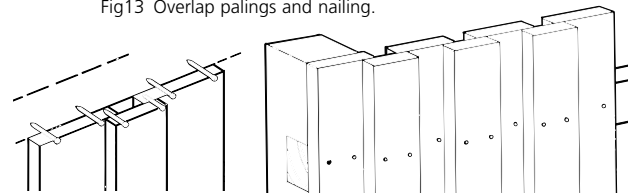
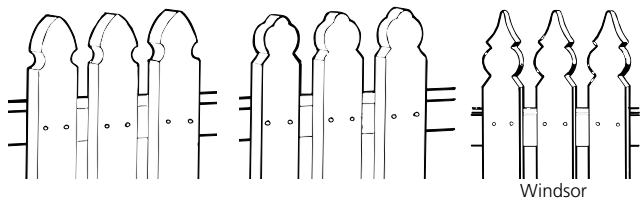

Fig13 Overlap palings and nailing.



- If you have decided on a picket fence, you will need to choose from the available profiles that best suit your needs. Usually pickets are cut from long lasting timbers such as Cypress Pine or Treated Pine, the most popular profile being the Windsor pattern.



Windsor

- For those who want a quick-fix picket fence, try the Cypress Pine picket fence panels available from Magnet Mart in lengths of 2740mm and either 1200mm or 1500mm high. These panels are simply fixed to posts (see Fig 14).

Fig14. Ready fixed fence panel.

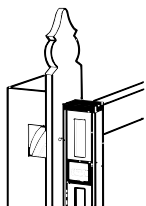
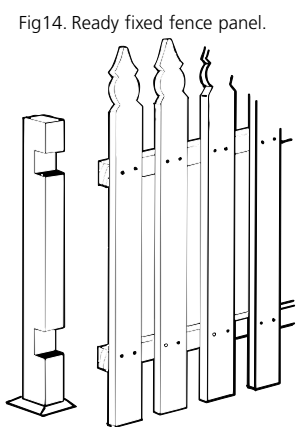
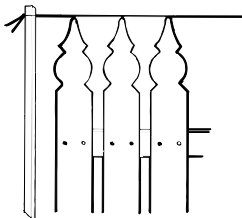

Fig15. Use a spirit level to ensure that picket is vertical. Use a string line to mark the height of the fence.



- To fix your own pickets, fix the first picket at one end of the fence, ensuring it is vertical using a spirit level (see Fig 15). Run a string line along the fence line that marks the height of the pickets (see Fig 15), ensure that every picket just touches the string line and you will have a neat fence.

- Choose a suitable gap, usually around 25mm, and fix the next picket to the rails. For an easy way to keep a constant gap between pickets, cut a piece of scrap timber to width and use it as a spacer (see Fig 16) and continue to fix the pickets to the rails.

Fig16. Keep constant gap between pickets with a piece of scrap timber.

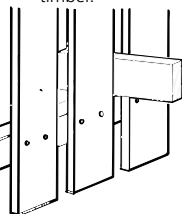

5. Topping the Fence

- Once all the palings are fixed to the fence, you will need to cut them all to the same height. This is easier using a power saw and a timber batten temporarily fixed to the back of the fence for the saw to run along (see Fig 17).

Fig17. Topping the fence.

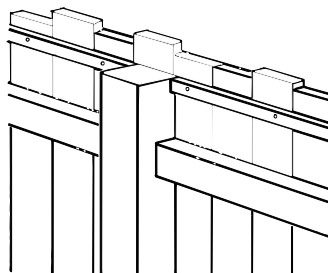

- Palings should be trimmed around 200mm above the top of the upper rail.
- Posts should be trimmed to paling height or just below, ensuring that you angle the top of the post to allow water to run off (see Fig 18).

- Palings may be fitted with a metal cap to prolong the life of the fence, special fence caps are available, or you can use 25mm aluminium channel (wider for overlapped palings), fixed with a screw every 500mm or so along the fence (see Fig 19).

Fig18 Angle post top for water run off.

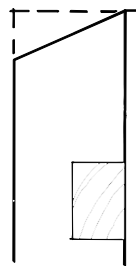
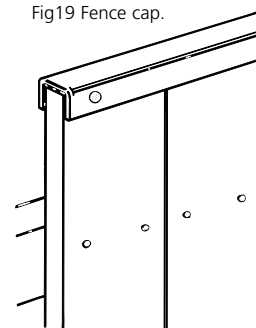

Fig19 Fence cap.



6. Fence Finish

- It is best to leave the fence for a few months prior to applying a fence finish. This gives the timber time to shrink. If you have used treated pine timber, you can apply a fence finish straight away.
- Talk to your local Magnet Mart store about the range of fence finishes available to protect and beautify your new fence.