

BUILD IT WITH
REDWOOD

Adirondack Chair



REDWOOD

- Naturally beautiful
- Easy to use
- Practical and economical
- Durable and stable
- Resistant to decay and insects

Adirondack Chair

The rounded wooden slats, oversized armrests and inviting slant-back design identify the classic Adirondack chair. Born a century ago in upstate New York, this chair quickly became a standard fixture at all lakeside retreats and summer camps.

To ensure that this casually elegant chair survives for generations to come, use one of the all-heartwood grades of redwood: Deck Heart or Construction Heart. These grades are naturally resistant to insects and decay.

BUILD THE CHAIR FRAME

For simplicity sake, this redwood chair is constructed almost entirely of 1x4s and 1x6s; the front legs are cut from 2x4s for maximum strength. You will start by assembling the frame of the chair, which includes the front and rear legs. Then you will finish by installing the slats that form the back and seat of the chair.

Use only corrosion-resistant screws to prevent staining. We recommend that you counterbore all visible surface screw holes with a $\frac{3}{8}$ -inch-diameter spade bit to a depth of about $\frac{1}{4}$ inch. Fill the holes with $\frac{3}{8}$ -inch-diameter redwood plugs, which you can make with a plug cutter.

Tools you will need Tape measure, combination square, cordless drill/driver or electric drill, power miter saw or hand saw, sabre saw with adjustable baseplate, assorted twist-drill bits, countersink bit, $\frac{3}{8}$ - and $\frac{7}{8}$ -inch-diameter spade bits, hammer, orbital sander or sanding block, $\frac{3}{8}$ -inch-diameter plug cutter and pencil compass. Optional: router with $\frac{1}{4}$ -inch-radius roundover bit.

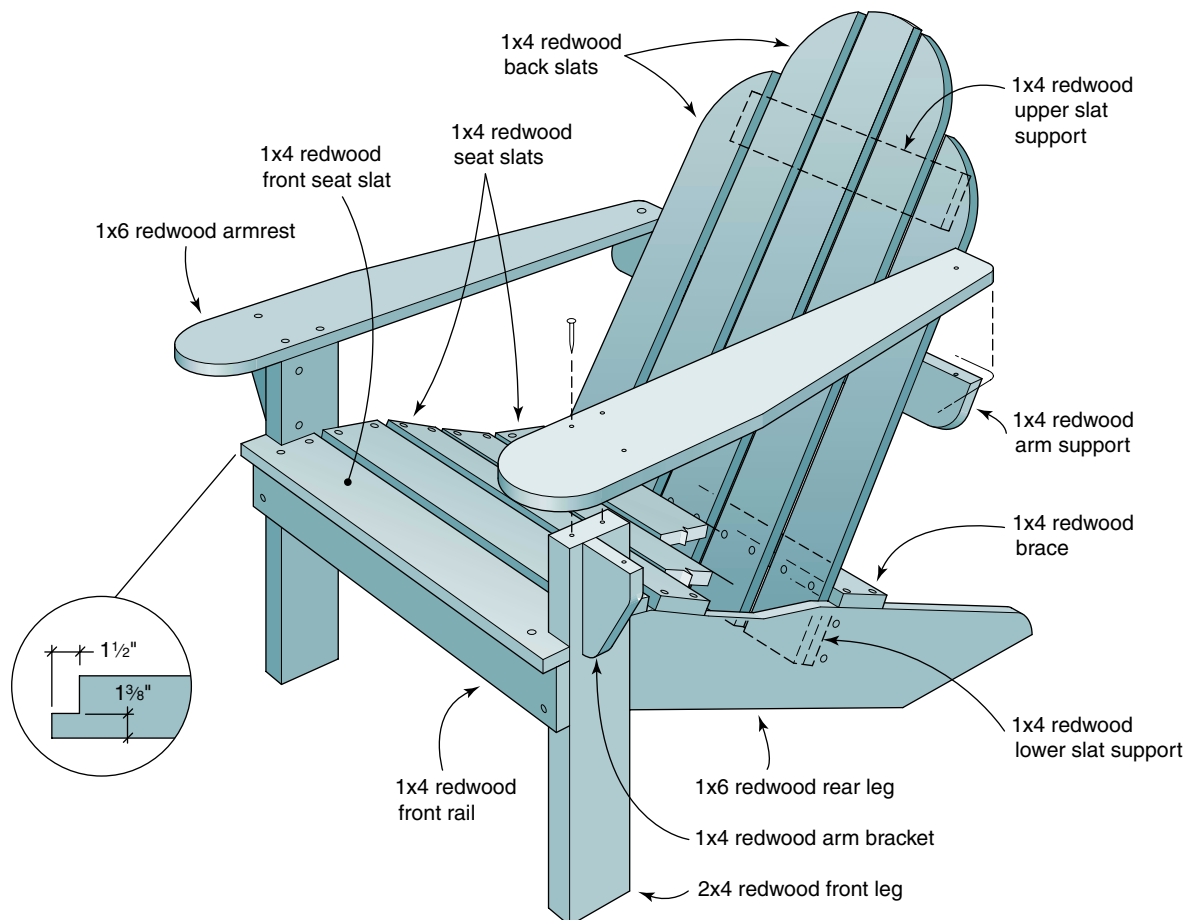

ASSEMBLE THE CHAIR

1. Legs Cut the two front legs from a 2x4, making sure that both ends of each leg are perfectly square. Next, cut two 36-inch-long pieces of 1x6 for the rear legs. Refer to the rear-leg pattern (shown below) and transfer the 2-inch square grid and other dimensions to the 1x6. Trim the first leg to its final shape using a sabre saw. Use this first leg as a template to cut the second leg to match.

Note that the ends of the legs are cut to a 25° angle and a portion of the upper edge is trimmed away to accept the five 1x4 seat slats. Round off the top, rear corner of the legs with the saw and then lightly sand the edges smooth.

2. Front rail, lower slat support and brace Cut to length the three 1x4 crosspieces that connect the right side of the frame to the left side. These pieces include the front rail, lower slat support and brace. Rip a 5° bevel along one edge of both the lower slat support and the brace. This accommodates the 85° slant of the back slats.

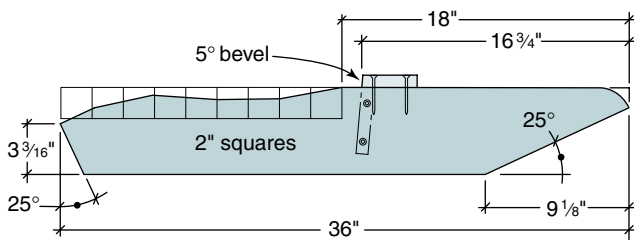

3. Assemble the legs Screw the front rail across the front legs, making sure that its top edge is 14 5/16 inch up from the bottom end of the legs. Next, place the rear legs against the inside surfaces of the front legs; align them flush with the top of the front rail. Attach each rear leg to the front leg with three 1 3/4-inch deck screws.

4. Complete the frame Install the brace 16 3/4 inches from the end of the rear legs and with its beveled edge facing toward the front of the chair. The 1x4 lower slat support will be installed later when assembling the chair back.

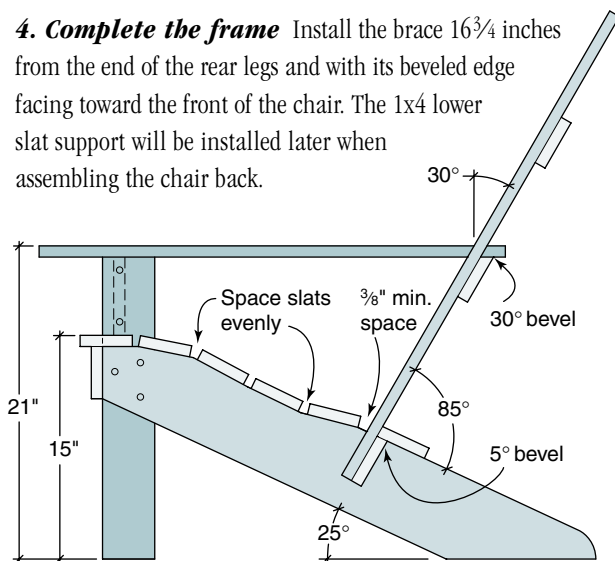

1. Back slats The seat and back of the chair are each made up of five 1x4 slats. For the chair back, cut the three center slats to 36 inches long and the two end ones to 30 inches. Also, cut to length the upper slat support and arm support, which get screwed across the rear of the slats. Note that the upper edge of the arm support must be bevel-ripped to 30°. Round off the bottom corners of the arm support to a 1 3/4-inch radius.

Lay out the five chair-back slats equally spaced on a flat surface and against a straight edge, such as a secured 2x4, to keep them aligned. Find and mark the centerline for the radius of the curved boards. From that point, use a pencil on a string or a compass to draw the radius across the tops of the three center slats.

Cut the rounded ends with a sabre saw, then sand them smooth with 120-grit sandpaper. Use one of the slats as a template to mark the radius onto the two 30-inch-long end slats.

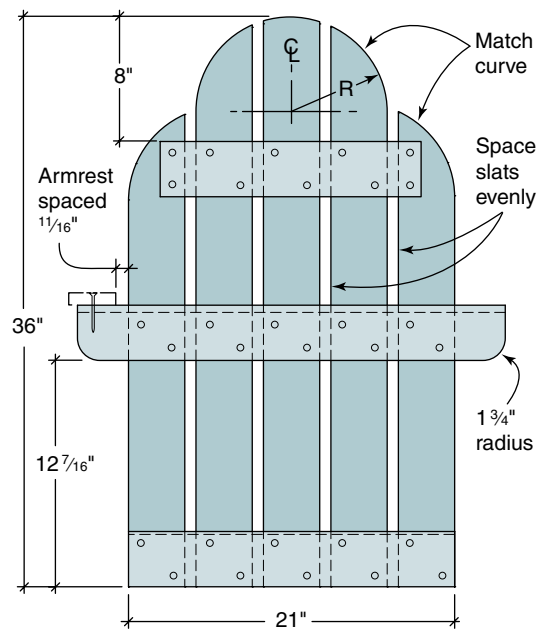

2. Assemble the chair back Again, lay out the chair-back slats, this time face down, on a flat surface. Secure or weight them so that they will stay aligned and square. Space them equally to 21 inches. Measure down eight inches from the top of the center slat and attach the upper slat support with two 1 1/4-inch screws per slat; do not overdrive or counter bore these screws or their sharp points will poke through the other side.

Attach the lower slat support across the bottom of the back slats, making sure its 5° bevel is facing up, toward the top of the chair back. Next, install the arm support across the slats making sure it extends beyond the slats an equal amount at each end and that its 30°-beveled edge faces up toward the top of the chair back.

ASSEMBLE THE CHAIR

3. Install the chair back Set the assembled chair back into the chair frame between the rear legs, pushed back against the brace. Lift up on the chair back so the top of the lower slat support butts tightly against the bottom of the brace. For now, secure the chair back to the brace with just two screws. Check the angle between the chair back and rear legs; it should be 85°. Installing the armrests next will hold the back at this angle allowing you to more easily finish its installation.

4. Armrests Cut the two 31³/₄-inch chair armrests from a 1x6 referring to the arm pattern to trim them to their final shape. Smooth the large round ends with 120-grit sandpaper. Use the orbital sander or the router to ease the top edges of the armrests for added comfort.

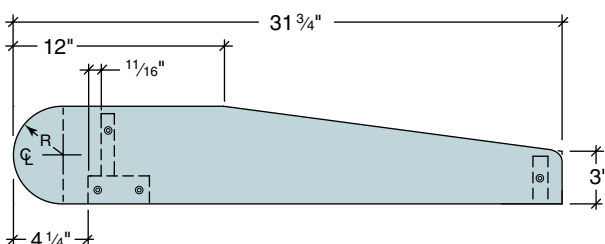

Cut the two short armrest brackets from a 1x4 and attach them flush with the tops of the front legs. Use two screws to secure each armrest on top of the front legs allowing a 4¹/₄-inch overhang. Finish attaching the armrests to the arm brackets and to the arm supports with one 1¹/₄-inch screw each.

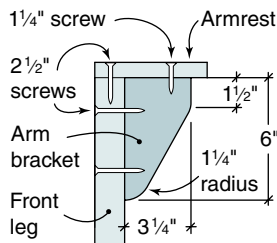

Once both armrests are installed, finish attaching the chair back to the brace by driving two 1¹/₄-inch screws through the end of each slat. Again, predrill pilot holes to prevent splitting the slats.

5. Seat slats Next, cut the five 1x4 slats for the chair seat. The front seat slat is longer than the other four slats because it wraps around the front legs. Cut a 1¹/₁₆ by 2¹/₈-inch notch into both ends of the front seat slat to allow it to fit around the front legs (see illustration). Use the router and roundover bit or orbital sander, if desired, to soften the top edge of the front seat slat.

6. Install the seat slats Install the seat slats onto the frame with equal spaces and with their ends flush to the outside of the rear legs. Leave a ³/₈-inch space between the last seat slat and the slats of the chair back to allow rain and debris to wash through to the ground and to not collect on the seat.

Finishing There are a variety of ways to finish the chair, depending on the look you desire. Refer to the Finishes section on the back of this brochure for finish formulas and their effects. You must first sand the wood smooth. Start with 100-grit sandpaper and sand all surfaces. Switch to 120-grit sandpaper for the final sanding.

Materials For Adirondack Chair

	Quantity	Size	Length
Legs and Framing			
Rear legs	2	1x6	36 inches
Front legs	2	2x4	20 ⁵ / ₁₆ inches
Front rail	1	1x4	26 inches
Brace	1	1x4	22 ³ / ₈ inches
Back			
Back slats	3	1x4	36 inches
Back slats	3	1x4	30 inches
Upper slat support	1	1x4	16 ¹ / ₂ inches
Lower slat support	1	1x4	21 inches
Arms			
Arm support	1	1x4	27 ⁷ / ₈ inches
Arm brackets	2	1x3 ¹ / ₄	6 inches
Armrests	2	1x6	31 ³ / ₄ inches
Seat			
Front seat slat	1	1x4	26 inches
Seat slats	4	1x4	22 ³ / ₈ inches
Deck screws	1 pound	1 ¹ / ₄ inches	
	¹ / ₂ pound	1 ³ / ₄ inches	
	¹ / ₂ pound	2 ¹ / ₂ inches	
Sandpaper	as needed	100, 120 grit	

Contact the California Redwood Association for more great publications containing redwood technical and building information. Call us toll free at 1-888-Cal-Redwood for a complete literature list or to ask for any of the titles listed here:

Other Construction Tipsheets

Deck Over Concrete	Mendocino Bench
Freestanding Deck	Lake Tahoe Gazebo
Calistoga Spa Surround	Petaluma Planters
Windsor Shade Shelter	Sonoma Picnic Table
Monterey Potting Center	Adirondack Swing

Also Available

Deck Construction	Deck Grades, Nails and Finishes
Fences for All Reasons	Landscape Architecture

Redwood

For beauty and performance, redwood is naturally superior to other woods. That's why it's the first choice for decks, fences and most outdoor projects. Redwood retains its beauty outdoors, shrinks and swells less than other woods and is less likely to warp, split, check or cup. With relatively little or no pitch, redwood is easy to drill, saw and shape. Redwood heartwood has natural durability and resistance to insects and will last longer outdoors than most woods.

Grades

The knotty garden grades of redwood are ideal for outdoor projects. These grades are beautiful, durable and economical.

Construction Heart/Deck Heart is all heartwood and contains knots; used for load-bearing applications near the ground. Deck Heart is graded for strength and is available in 2x4 and 2x6.

Construction Common/Deck Common contains sapwood and knots; used for decking and above-ground uses. Deck Common is graded for strength and is available in 2x4 and 2x6.

Merchantable Heart is all heartwood and contains larger knots than Construction grades; used near the soil.

Merchantable contains sapwood and larger knots; used for fence boards, rails and above-ground uses.

Finishes

Redwood accepts finishes better than most woods. Some heighten redwood's natural beauty, bringing out the color and the grain. Others help the wood harmonize or contrast with surrounding structures. Read the labels on all finish products before using.

No-finish option Redwood performs better than most woods if left unfinished. This no-maintenance option will result in redwood weather-bleaching to a soft driftwood gray

Clear water repellent finish is recommended to stabilize the color at tan.

Semitransparent stains in "redwood" shades tint the wood without hiding the grain.

Solid-color stains or paints should be applied over compatible oil-based primers.

Fasteners

Use only non-corrosive hardware such as aluminum, stainless steel or top quality hot-dipped galvanized screws or nails.

Ordinary nails and screws will cause stains.