

20

# SIX-DRAWER CHEST

*Curly Maple, Walnut*



## MAKING THE SIX-DRAWER CHEST

After the stock for the top, bottom and ends of the case has been thickened, ripped to width, and cut to length, each must be given a 1/4" X 5/16" rabbet that will later receive the back panel. At this time, cut the through dovetails at each corner. *The rabbet complicates this process, but there are a couple of easy choices you can make here: (1) miter the material that will house the rabbet, or (2) use a Jap joint in which the rabbets on the case's top and bottom simply lap the rabbets on the ends.*

After fitting the dovetails, lay out and cut the dadoes for the partitions between drawers. Then glue-up the case.

After the glue on the dovetails has cured, slide the partitions into place with a bit of glue spread in the dadoes. Drive brads through the top, sides and bottom of the case to help hold these partitions.

Fit the tenons at the top of each leg into mortises drilled into the bottom of the case, and affix the back panel in its rabbet using 1/2" no. 6 wood screws passing through oversized holes (to allow for wood movement as the panel expands and contracts in response to seasonal changes in humidity) in the panel.

Except for the big, fat dovetail at each corner, drawer construction is conventional. Plough a 1/4" X 1/4" groove on each drawer side and on the back of the front. These will receive the 1/4"-thick drawer bottom. The back of the drawer is not as high as the sides; it extends down only as far as



Partially open drawers reveal the fat dovetails.

the top of the drawer bottom. Nail through the drawer bottom, up into this drawer back.

For a larger, weight-carrying drawer, the single dovetail at each corner would be a poor choice, but for such a tiny drawer, one that will never carry more than a few ounces of load, the single dovetail provides a joint offering a fair amount of mechanical resistance to forward pull and a fair amount of glue surface.

Turn the drawer pulls from walnut and fasten them in place with a thin tenon fit into a mortise drilled into the drawer front.

---

## BUILDING THE DRAWERS

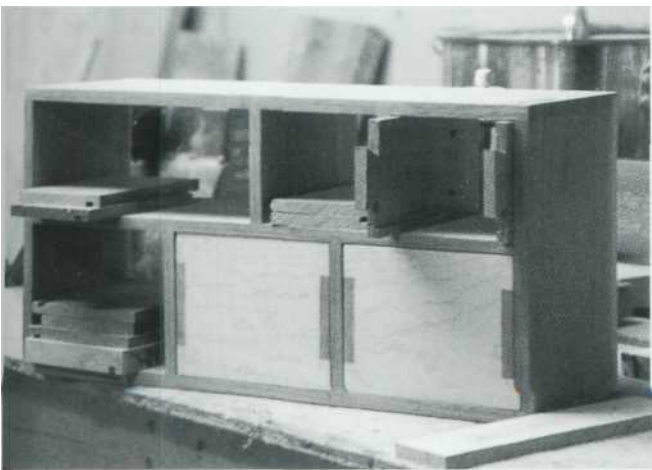

Each drawer is custom-fit into its opening. First, plane the sides to the right height—one that permits them to slide into their openings with the least amount of clearance.



**2** Cut dovetails using a backsaw and a coping saw. Use a parting chisel to achieve final fit.

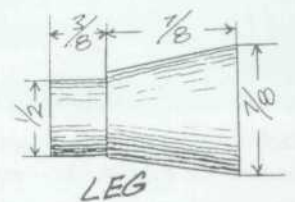
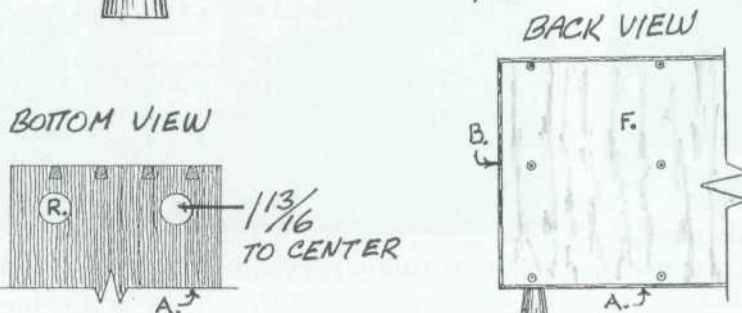
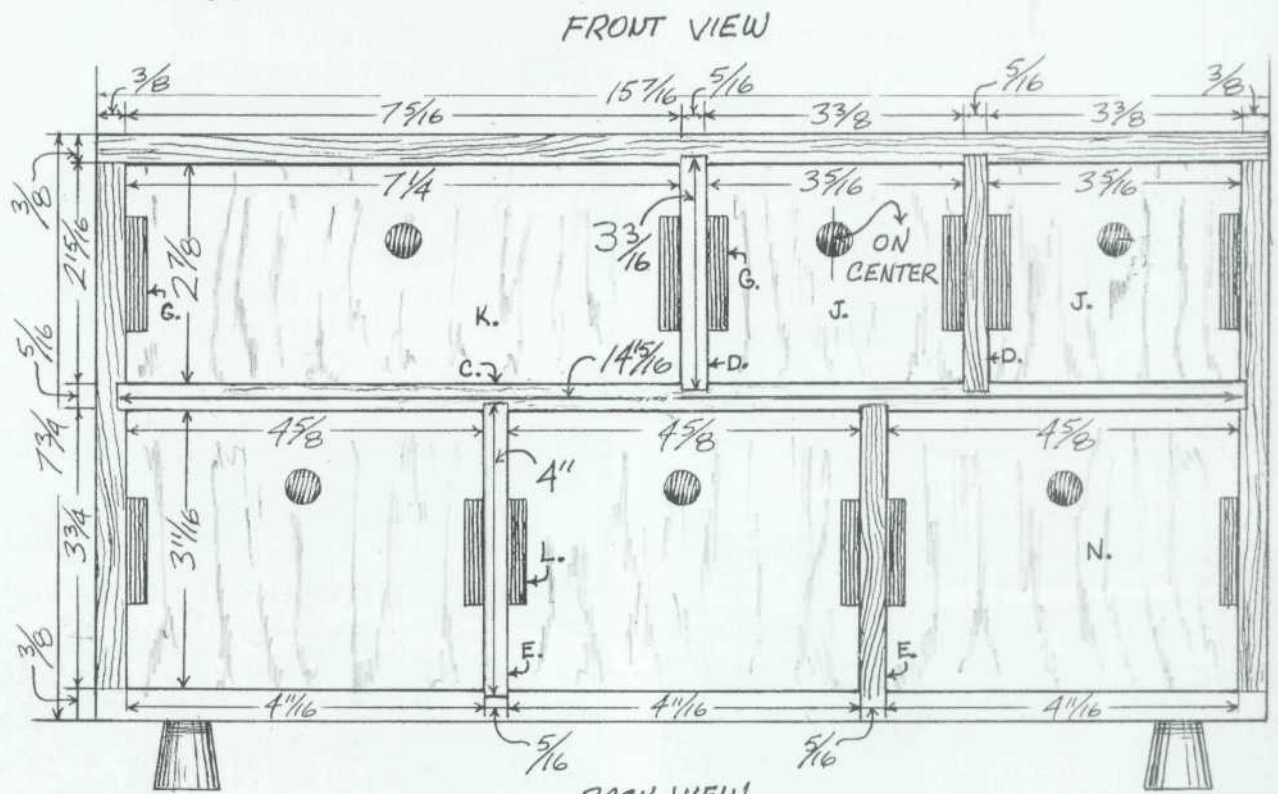
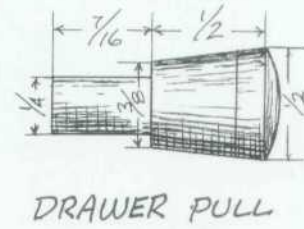
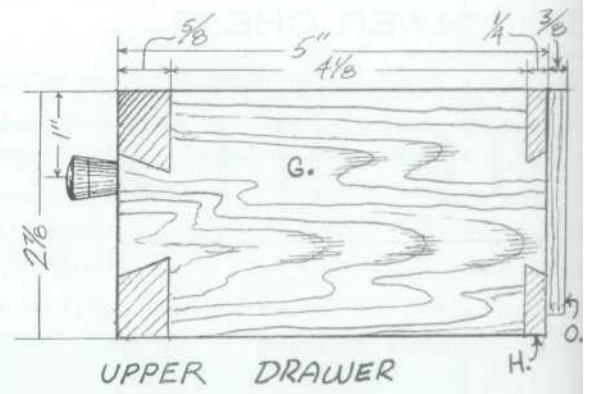
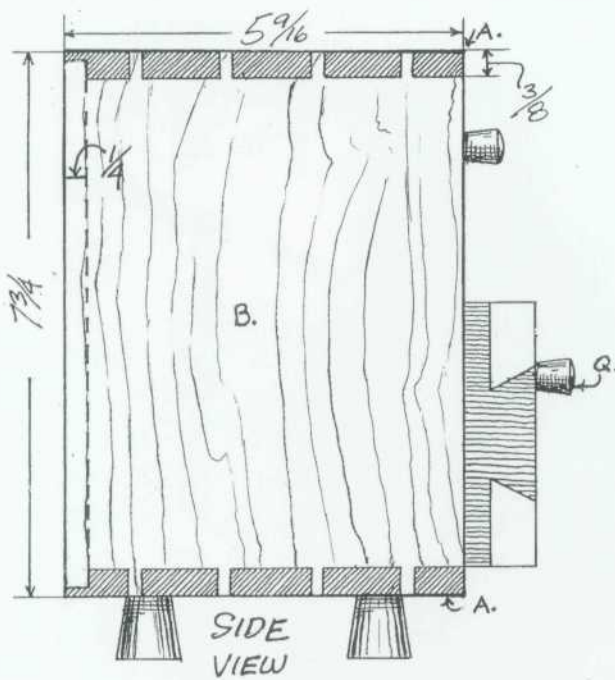

## BUILDING THE DRAWERS

<CONTINUED>

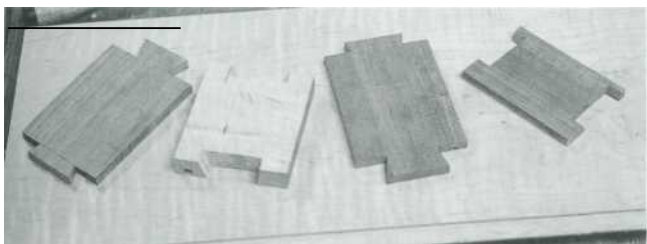

**3** After its parts have been cut and fit, the drawer is ready to assemble. Brads help the glue hold the drawer sides in place.

**4** Note the surplus length at each corner.

This is ground off with a belt sander

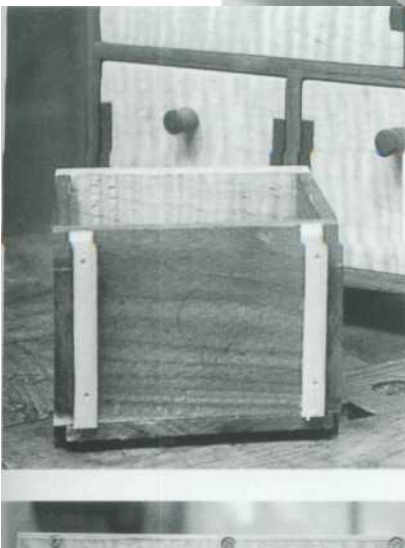
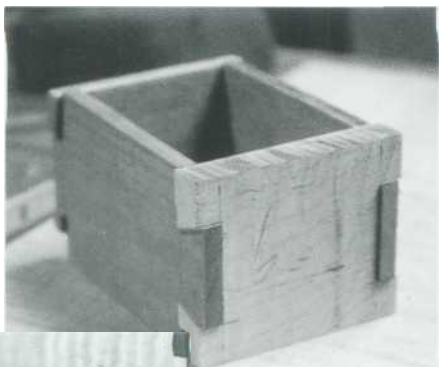

**5** After sanding the sides and the front of the drawer, slide the bottom into place and fasten with brads. Plug the holes at the ends of the grooves on both sides of the drawer front. Plane thickness from the two strips of softwood tacked to the back of each drawer to achieve final fit.

**CHEST BACK** The back is unglued, fastened with screws to the case's top, bottom and central partitions.

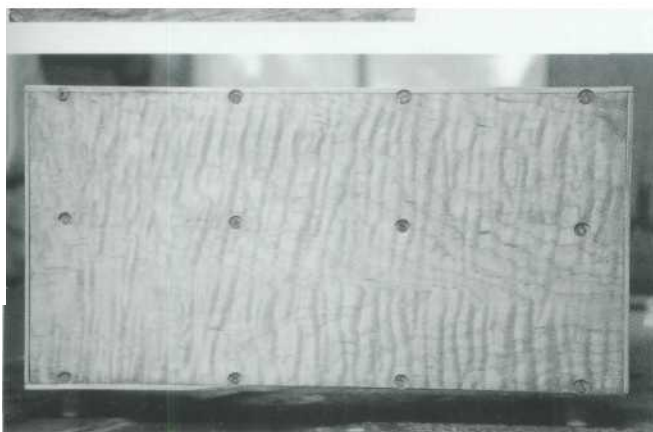

**BACK RABBET** This photo shows the lapped rabbet corner at the back of the case

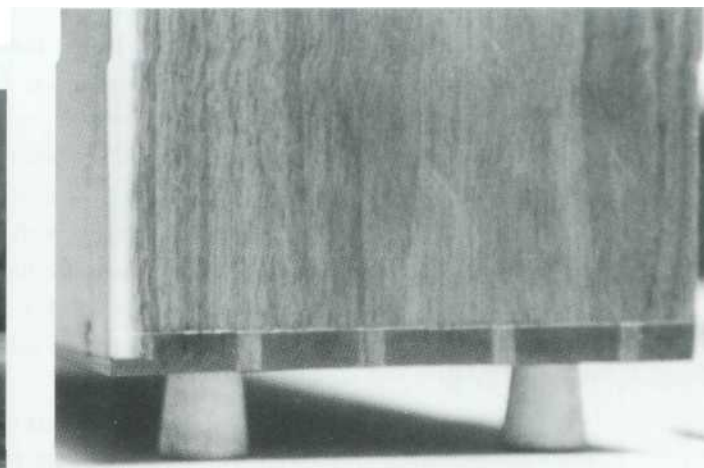

### MATERIALS LIST

#### Case

A	Top and bottom	2 pcs.	$\frac{3}{8} \times 5\frac{5}{16} \times 15\frac{7}{16}$
B	End	2 pcs.	$\frac{3}{8} \times 5\frac{5}{16} \times 7\frac{3}{4}$
C	Central partition	1 pc.	$\frac{3}{16} \times 5\frac{1}{4} \times 14\frac{1}{16}$
D	Upper partition	2 pcs.	$\frac{3}{16} \times 5\frac{1}{4} \times 3\frac{3}{16}$
E	Lower partition	2 pcs.	$\frac{3}{16} \times 5\frac{1}{4} \times 4$
F	Back panel	1 pc.	$\frac{1}{4} \times 7\frac{1}{2} \times 15\frac{3}{16}$

#### Upper Drawers

G	Side	6 pcs.	$\frac{1}{4} \times 2\frac{7}{8} \times 5$
H	Short back	2 pcs.	$\frac{1}{4} \times 2\frac{3}{8} \times 3\frac{3}{16}$
I	Long back	1 pc.	$\frac{1}{4} \times 2\frac{7}{8} \times 7\frac{1}{4}$
J	Short front	2 pcs.	$\frac{3}{8} \times 2\frac{7}{8} \times 3\frac{3}{16}$
K	Long front	1 pc.	$\frac{3}{8} \times 2\frac{7}{8} \times 7\frac{1}{4}$

#### Lower Drawers

L	Side	6 pcs.	$\frac{1}{4} \times 3\frac{1}{16} \times 5$
M	Back	3 pcs.	$\frac{1}{4} \times 3\frac{3}{16} \times 4\frac{3}{8}$
N	Front	3 pcs.	$\frac{3}{8} \times 3\frac{1}{16} \times 4\frac{3}{8}$

#### Miscellaneous

##### Softwood fitting strip

O	Upper drawer	6 pcs.	$\frac{1}{4} \times \frac{3}{8} \times 2\frac{3}{8}$
P	Lower drawer	6 pcs.	$\frac{1}{4} \times \frac{3}{8} \times 3\frac{3}{16}$
Q	Pull	6 pcs.	$\frac{1}{2} \times 1$ (this includes tenon length)
R	Leg	4 pcs.	$\frac{7}{8} \times 1\frac{1}{4}$ (this includes tenon length)

\*These are net measurements. A surplus should be added to dovetailed parts to allow them to be sanded flush.

\*Opening measurements are given for drawer width and height. I subtract  $\frac{1}{16}$  from both dimensions. This gives me  $\frac{1}{32}$  clearance on all four sides of drawers.