

HOW-TO BOOKLET #3110

BASIC DECKS



TOOL & MATERIAL CHECKLIST

- Deck Lumber, Fasteners
- Hangers
- Hammer/Saw/Level
- Carpenter's Square
- Shovel/Trowel
- Cement
- Chalkline
- Tape Measure
- Drill/Drill Bits
- Adjustable Wrench
- Safety Glasses
- Marking Pencils

Read This Entire How-To Booklet for Specific Tools and Materials Not Noted in The Basics Listed Above

Think of a deck as a floor structure. It has joists to support the flooring material (decking) and posts to hold the unit up off the ground—slightly elevated or higher.

The lumber can be redwood, cedar, cypress, or pressure treated fir, hemlock, spruce. The footings should be concrete, and any support posts 6X6-inches square. You can use 4X4-inch posts up to about 6 feet of deck height; the larger size is recommended just to make sure the support is always adequate. Refer to the beam, post, and span tables included.

The deck design can be square, rectangular, and, perhaps, somewhat free-form or two-level. Plan and design the deck before buying any tools and materials. By doing so, you will eliminate many mistakes and save time and money throughout the project.

This booklet is about building basics only. It does not address deck design in any detail.

NOTE: You may need a building permit to construct a deck in your community. Check with the Building Department authority in the community. The usual procedure is to submit a drawing of the proposed deck structure to the building inspector in the Building Department. Any changes to meet local codes and requirements will be indicated. If okay, you will be issued a building permit usually for a fee. The permit may be time limited—probably not to exceed 3, 6, 9, or 12 months.

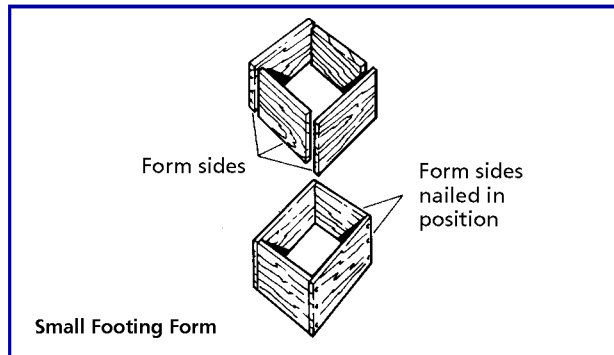

While you're building the deck, an inspector may visit to examine various parts of construction. Two vital points will be the foundation or piers and the completed structure. The procedure varies widely from community to community. It is important that you check before starting any building procedures. Keep in mind that the codes are there to protect you. Another good idea is to let your neighbor know that you're building a deck (or a fence structure to go with the deck). You may need the neighbor's cooperation, especially if site access is needed by trucks.

BUILDING BASICS

Most decks have 8 building elements: concrete footings; concrete piers; posts; a ledger support strip; beams; joists; rim (skirt) joists; decking. There are three options: railings, benches, and stairs (see How-To Booklet #3111).

There are 11 deck building procedures. In order: design the deck; obtain the necessary building permits; buy the materials; prepare the site; layout the footings; set the footings; set the posts and beams; install the joists; nail on the decking; trim the decking; install any options such as railings and benches.

CONCRETE FOOTINGS

The building codes in your community will be very specific about this deck component (usually). However, here are several rules of thumb for planning purposes:

If possible, footings should be placed on undisturbed soil or rock. The footings must extend below frost line in your area, which ranges from 24 inches minimum to 48 inches maximum. You can find out the frost line depth in your area by phoning the National Weather Service. If this agency is not conveniently reachable, your local Building Department will know the frost line depth.

Footings usually are placed concrete in rectangular, square, or circular shapes depending on the post connection. Most footings extend 2 to 6

MINIMUM BEAM SIZES AND SPANS

SPECIES GROUP 1	SPACING BETWEEN BEAMS, FT.									
	Beam size	4	5	6	7	8	9	10	11	12
	4x6" x	6	6	6						
	3x8" x	8	8	7	7	6	6	6		
	4x8" x	10	9	8	7	7	6	6	6	
	3x10" x	11	10	9	8	8	7	7	6	6
	4x10" x	12	11	10	9	9	8	8	7	7
	3x12" x		12	11	10	9	9	8	8	8
	4x12" x			12	12	11	10	10	9	9
	6x10" x					12	11	10	10	10
	6x12" x						12	12	12	12
SPECIES GROUP 2										
	4x6" x	6	6							
	3x8" x	7	7	6	6					
	4x8" x	9	8	7	7	6	6			
	3x10" x	10	9	8	7	7	6	6	6	
	4x10" x	11	10	9	8	8	7	7	7	6
	3x12" x	12	11	10	9	8	8	7	7	7
	4x12" x		12	11	10	10	9	9	8	8
	6x10" x			12	11	10	10	9	9	9
	6x12" x				12	12	12	11	11	10
SPECIES GROUP 3										
	4x6" x	6								
	3x8" x	7	6							
	4x8" x	8	7	6	6					
	3x10" x	9	8	7	6	6	6			
	4x10" x	10	9	8	8	7	7	6	6	6
	3x12" x	11	10	9	8	7	7	7	6	6
	4x12" x	12	11	10	9	9	8	8	7	7
	6x10" x		12	11	10	9	9	8	8	8
	6x12" x			12	12	11	11	10	10	8

Beams are on edge. Spans are center to center distances between posts or supports. Grade is No. 2 or Better; No. 2 medium grain Southern pine.

Species Group 1: Douglas fir, larch, Southern pine.

Species Group 2: Hemlock fir, Douglas fir, south.

Species Group 3: Western pines and cedars, redwood, spruces. **Example:** If the beams are 9 feet 8 inches apart and the Species is Group 2, use the 10 foot column; 3X10 up to 6 foot spans, 4X10 or 3X12 up to 7 foot spans, 4X12 or 6X10 up to 9 foot spans, 6X12 up to 11 foot spans.

inches above ground (grade) level; if posts will be embedded into concrete, the posts must be treated for rot and insect resistance (such as termites).

READY THE SITE

Clean away all trees, shrubs, grass, big rocks, and other debris BEFORE you order material.

The ground should slope away from the house slightly for adequate drainage.

If a lot of soil must be moved to provide this slope, it is recommended that you have the soil moved professionally. The cost may not be as prohibitive as you might think. It's worth a check and three bids.

STAKE OUT THE DECK

With wooden stakes and chalkline, square the deck to the house. By doing this, you also have created the shape of the deck with string.

Take your time with this task. Getting it correct at this point can save you plenty down the line. The stake-out will be used to determine all other deck dimensions as you proceed.

STAKE OUT THE FOOTINGS

Using the stakes again, locate the footing positions. Most posts are set back from the leading edge of the deck by 18 to 24 inches.

If the footing location happens to coincide with an underground utility, you may get the utility moved, or you will have to relocate the deck.

The size and number of footings are determined by the size of the deck and its expected load. Generally, for most decks, footings are placed on 5-foot centers, front, middle, and back. If there will be lots and lots of weight on the deck, the footings can be 4 foot on-center for support. Don't skimp. It's better to overdo it slightly than underdo it.

When you have determined position, stake the position so the stakes are "on-center" within the footing area. An auger or clamshell type posthole digger can be used to dig the footing holes.

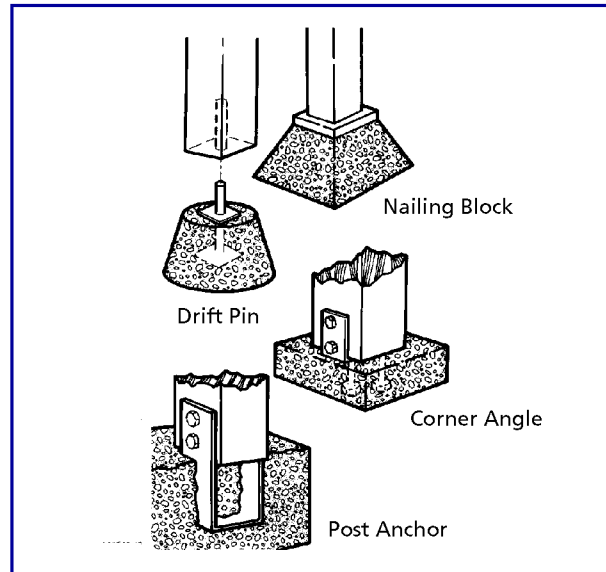

However, it is suggested that you contract this work—especially if there are lots of holes for you to dig.

If the footings are circular, you can buy a forming material called Sona Tube. The tube is set in the footing hole, concrete is placed in the tube, and the top leveled. When the concrete has hardened, the tubes can be stripped quickly and easily. If the foundation will be square, you will have to form the top of the hole with 2X4s to create this configuration. After the concrete has hardened in the form for at least 5 days, the forms may be removed. Let the work set longer if possible.

SETTING POSTS & BEAMS

If posts are embedded in concrete footings, square them in the footing when the concrete is placed. If a drift pin, nailing block, post anchor, or corner angle is used for post support, all are positioned on or into the footing at the time the concrete is placed. These fasteners must be level and plumb; double check them to be sure.

Posts are now attached to post-seats with bolts, excepting drift pins. As the post-fastening takes place, use scrap framing lumber to brace the posts.

Attach the beams to the posts. The most efficient way is to tack-nail one beam to the outposts within a row. To do this, first attach the beam closest to the house. It must be level and at the right height. Continue to attach the rest of the beams the same way, leveling them to the first beam installed.

Once the beams are up, select a very straight 2X4 and lay it over the beams. Level it. Check the diagonal level as well. Make any adjustments, and then lag screw all the beams to the posts. Use washers and three or four lags per connection.

Repeat the sequence with another set of beams. Install these on the inside of the posts. Level them and fasten with lags the same way as you did the first set. Double check level.

Now, measure from a constant point on the deck to the beam cutoff at the end of each set of beams. Verify this by using a chalkline from one end to the other end to make sure all beam ends will be cut at the same point.

INSTALLING THE JOISTS

Joists are set on the beams. Simplify the job by installing the skirt joists first.

Toenail them to the beams and where they cross all other beams. On the inside of the skirt, put down the joist pattern (usually on 24-inch centers) if your plan calls for it. Then put down one joist. The distance from the center of that joist to the next one will be 24 inches.

Start at one end of the deck and work to the opposite end. Don't be upset if the last two joists have less space than 24 inches. If your decking pattern will be zig-zag, herringbone, or diamond, use blocking between joists. Sight down each joist and set it so the "crown" is facing up.

The joists are nailed to the skirts and at the beams, where possible, and the blocking is nailed to the

joists, at 2 and/or 4 foot, intervals. It is recommended that you use 16d hot-dipped galvanized nails to assemble the deck. You also can use metal connectors to attach or support joists at beams. See drawings.

DOWN WITH THE DECKING

Once the joists are in position, the decking goes down. Make sure that the curved end grain of the wood faces downward to eliminate cupping.

Make the nailing pattern uniform. First lay a chalkline along each joist span. Drive two nails at each joist, along the line. The butt joints of the decking should line up over the joist and be centered. After you nail the first deck board, leave 1/8- to 1/4-inch space between each board. Use 16d hot-dipped galvanized casing nails; the nails also can be used to space between decking boards since they're about 1/8-inch "thick."

If you find the deck boards are not exactly parallel, don't try to correct all of the problem by adjusting the next board. Adjust gradually over the next two, three boards. Keep checking dimensions, based on the first board; chances of misalignment will be much less.

When you're about 6 feet from finishing, plan how to make the last piece of decking fit flush with the skirt. Space the remaining boards to coincide with the edge of the skirt.

If in doubt, lay out the boards to fit the skirt before nailing them down. You are now ready to trim the deck to final dimensions. See the drawing at bottom far right.

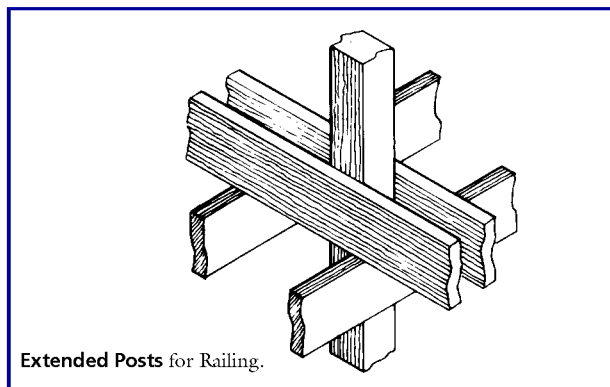

TRIMMING THE DECKING

Check all dimensions TWICE before you start the trimming procedures. Trim from the house out.

When you saw, try to keep the saw away from the skirt, unless the deck boards will overlap the skirt. A chalkline will help you see the cut line. To cap the end of the cut decking, as well as to provide an edging strip, you can install a molding piece around the edge of the deck boards.

Railings, steps, and benches are usually added after the deck is completed. If a railing is planned, it can be attached to the skirting or joists—and sometimes the beams. It also can be part of the post structure, but plan it this way at the start.

