

Camp Chair Plans

These plans are based upon several designs used by scouts in our council. Some people call this a scissors chair. The chair is composed to two pieces: the seat and the back. The two pieces slip together and require no fasteners when used. When carried the seat stows between the sides of the back for a very compact package.

Note: the legs are cut out of larger pieces so they can be curved.

Materials List:

- Seat Legs(2) - 3/4"x4.5"x33.75"
- Back Legs(2) - 3/4"x6"x37.75"
- Back Slats(11) - 3/8"x1.5"x19"
- Seat Slats(7) - 3/8"x1.5"x19"
- Seat Supports(2) - .75"x1.5"x18"
- Seat Spreader(1) - .75"x1.5"x13"
- Back Spreader(1) - .75"x1.5"x15"

All pieces are cut from a strong hardwood like oak. The Seat Legs and Back Legs are cut from these pieces to formed curved pieces. The Seat Leg is 2" wide. The Back Legs are 2.5" wide except for regions that taper to 3" wide to form 1/2" backstops for seat supports. See the seat support detail.

If a softwood or plywood is used it is best to increase thickness of the legs from .75" to 1" and increase the thickness of the slats from 3/8" to 1/2". All parts are glued with water-proof glue and fastened with 4d galvanized finish nails or rust resistant screws.

Assembly Views:

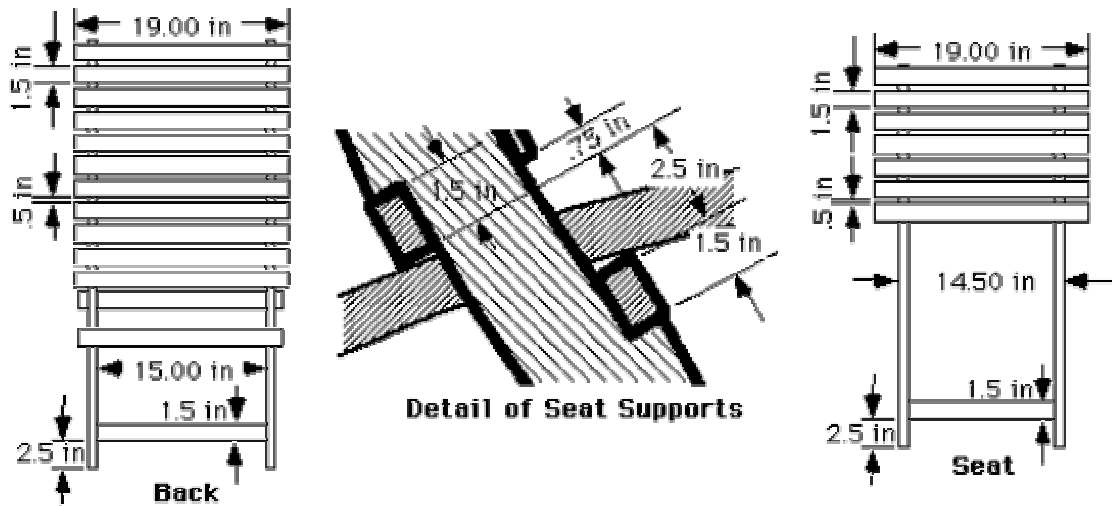

Assembly Notes:

1. Choose strong pieces of wood for the chair.
2. The slats for the back and seat are 3/8" (actual dimension) material mounted on 2" centers.
3. The other pieces are 3/4" (actual dimension) material.
4. The back has 1/2 inch notches as shown in seat support detail to back up the two seat supports.
5. Sand all pieces to prevent splinters.
6. Use rust-resistant screws and water-proof glue.
7. Use water-proof glue and screws to fasten the seat supports and spreaders to the legs.
8. Use water-proof glue and 4d galvanized finish nails to fasten the slats in place.
9. Finish with a nontoxic penetrating exterior finish.

For a lighter version:

- Seat Legs(2) - 3/4"x4.5"x33.75" - 10.5" apart on outside to outside.
- Back Legs(2) - 3/4"x6"x37.75" - 11" apart inside to inside
- Back Slats(11) - 3/8"x1.25"x15" - spaced on 2" centers
- Seat Slats(7) - 3/8"x1.5"x15" - spaced on 2" centers
- Seat Supports(2) - .75"x1.5"x14"
- Seat Spreader(1) - .75"x1.5"x9"
- Back Spreader(1) - .75"x1.5"x11"