

Patrol Table Plans

- **Perspective View and Front View**
- **Materials List and Cutting Guides**

These plans are based upon several designs used by troops in our council.

Note: the materials list shows how to cut all of the pieces out of one 4' x 8' sheet of 5/8" plywood. The plywood should be exterior grade with one smooth sanded surface. All cut edges need to be sanded. The cleats should be fastened with waterproof glue and rust resistant screws. A good penetrating oil finish will further prevent splinters and improve the life of the table.

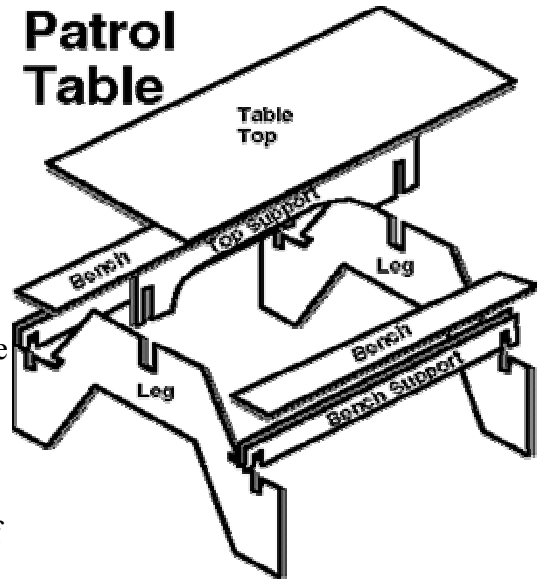

Return to top.

Materials:

- 4'x8' sheet of 5/8" exterior plywood with one smooth sanded surface.
- Exterior penetrating finish
- 1" Rust resistant screws
- Waterproof glue

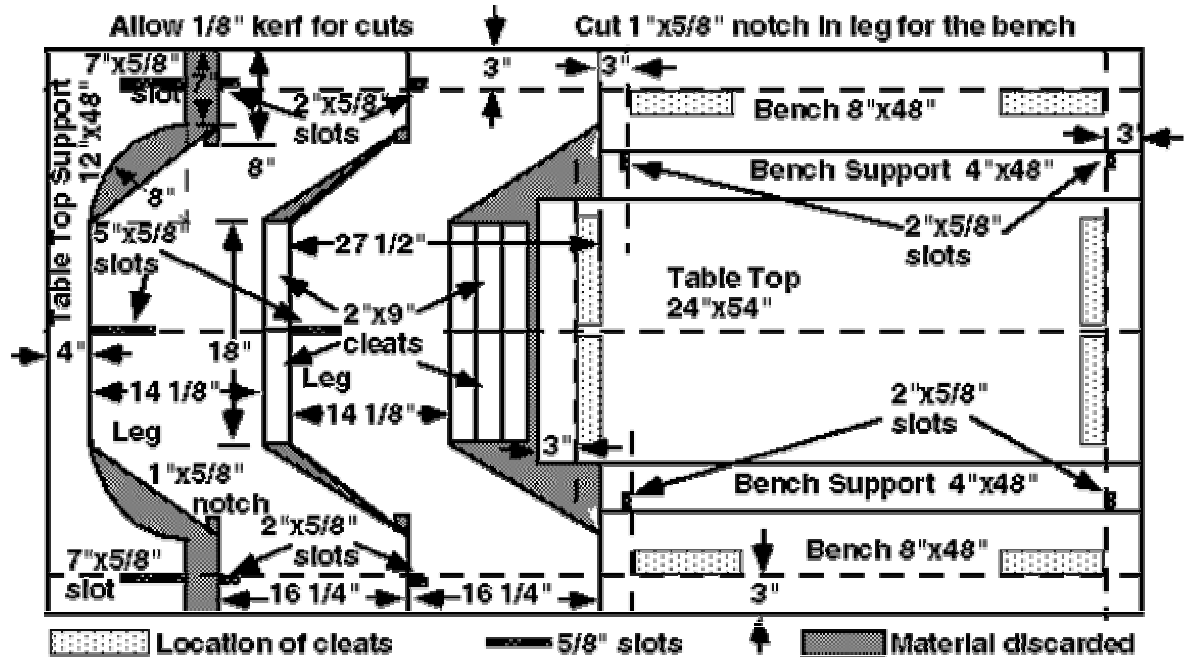

Notes:

1. When cutting top support you may use an 8 inch radius for the curved section.
2. Bench Supports have a 2"x5/8" slot for legs centered 2 11/16" from each end.
3. Legs have a 2"x5/8" slot for bench supports centered 2 11/16" from each end.
4. Legs have a 5"x5/8" slot for the top support centered in top.
5. Top support has 7"x5/8" slot for legs centered 2 11/16" from each end.
6. Legs have a 1"x5/8" notches to lock the benches in place.
7. The cleats are positioned to keep benches and top from sliding.
8. Fasten the cleats in place with rust-resistant screws and water-proof glue.
9. Finish with a nontoxic penetrating exterior finish.