

# Corner Door Computer Desk

## 1. Introduction

You can make a classic modern American desk by simply placing a door on the top of two two-drawer filing cabinets. It is large, simplicity itself to make, and easy to move. It has been a favorite with American students for 40 years.

Unfortunately the most common design for this desk has a number of shortcomings that make it unsatisfactory for a low-stress computer desk. The surface is much too high for a keyboard. The desk is too big for most dorm rooms. The filing cabinets are expensive, take up leg room, and who needs two anyway.

This design addresses these problems so that any student -- yes that means you -- can make a good, low-stress desk. This fifth version fits into the corner of a room and can be made any length to suit your floor space. It has simple-to-make legs so you have lots of leg room.

## 2. Sketches

### 1. Corner Door Computer Desk (above)

At the start of this note is a drawing of the fifth version of this desk. It shows the front and the underside of the door with wooden legs and the keyboard drawer. You can trim the door to any length to fit your room.

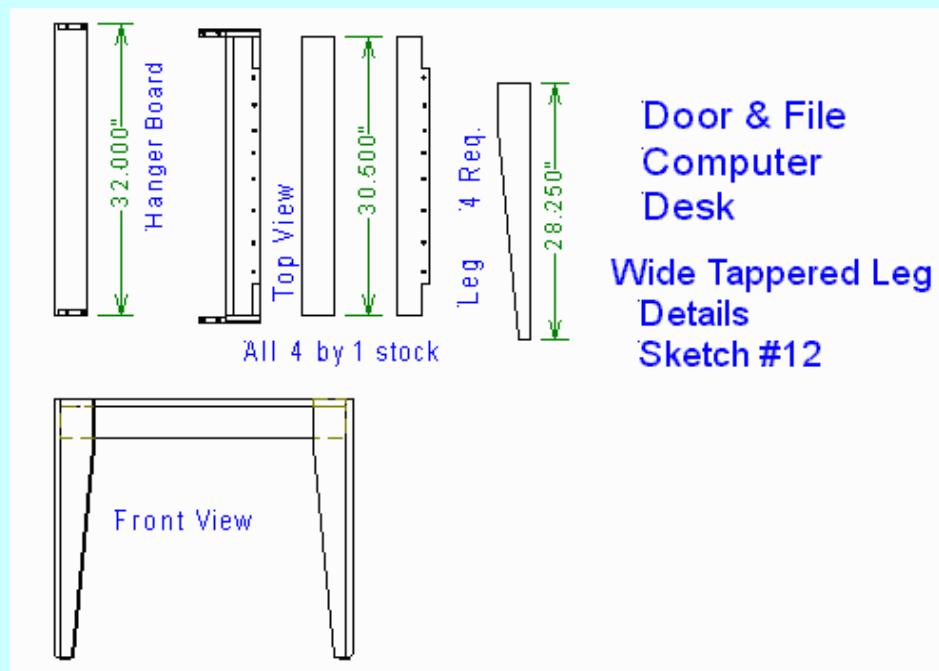

### 2. Wide Tapered Leg Details, Sketch #14

This sketch show the parts to build the legs. All the parts are easily cut from 1 by 4 stock.

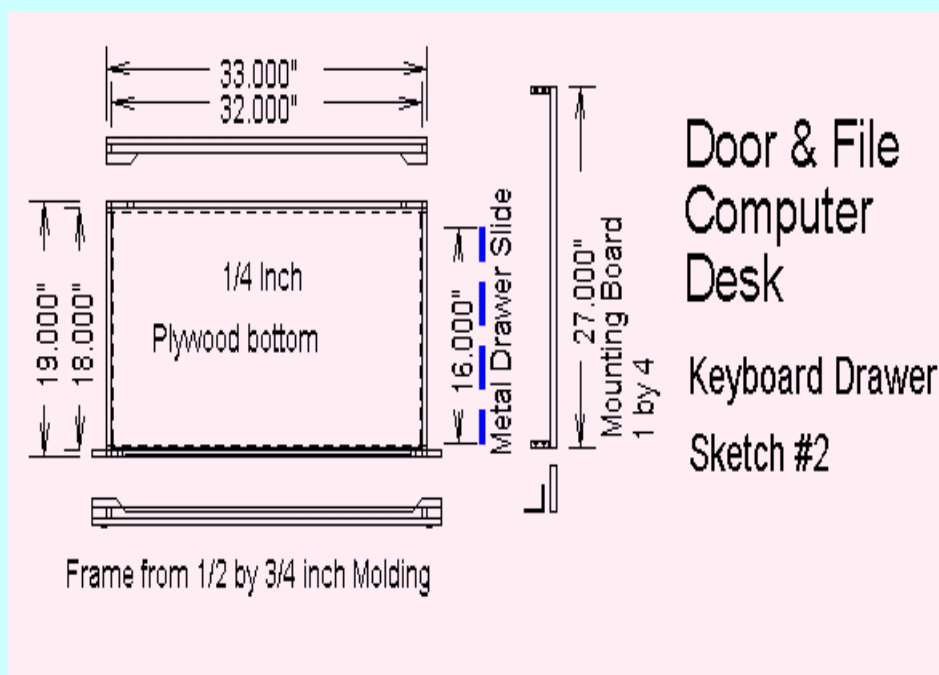

### 3. Keyboard Drawer, Sketch #2

The keyboard drawer is large enough for an ergonomic keyboard with the mouse pad beside it. It is a simple shallow drawer mounted on metal drawer glides and hung below the desk top.

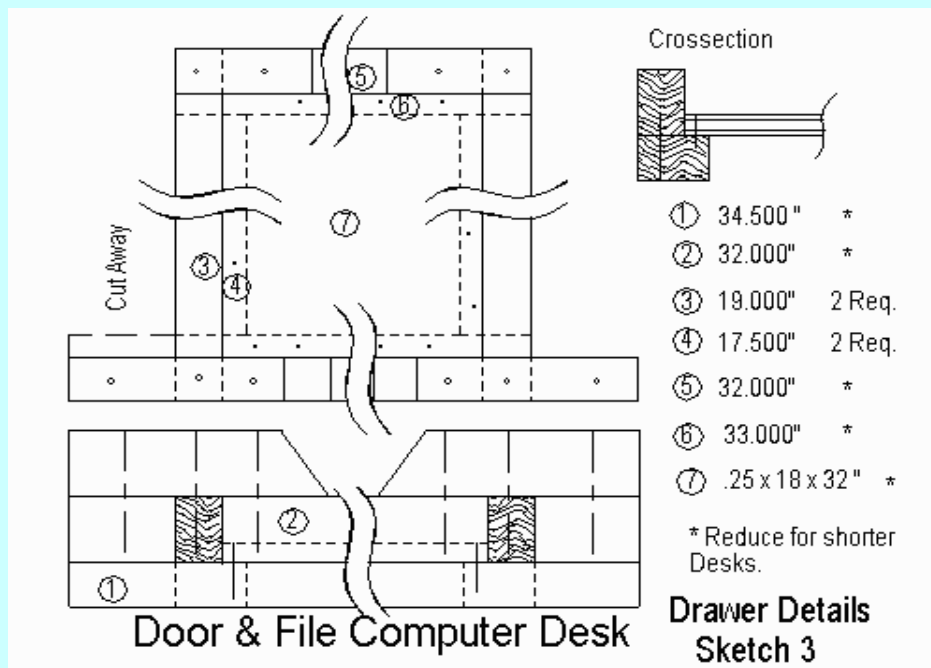

### 4. Drawer, Sketch #3

This sketch shows details of the construction of the keyboard drawer. It is simply made by cutting 5. by .75 inch molding with a hand miter box. The piece lengths are given for this

desk.

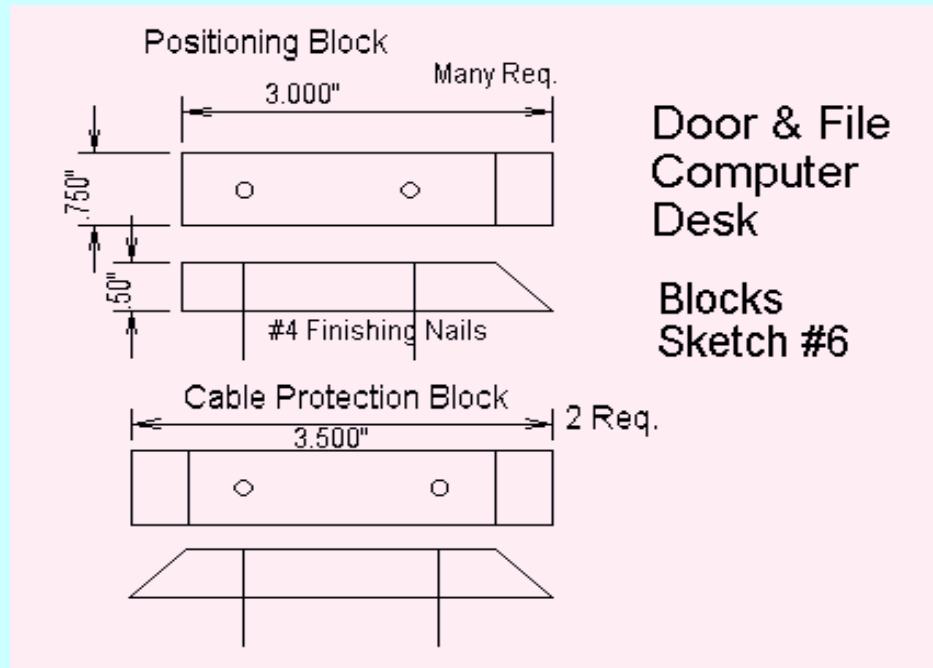

### 5. **Blocks, Sketch #6**

The blocks are cut from .5 by .75 inch rectangular molding with a hand miter box. Eight Positioning Blocks are needed for this desk.

## 3. **Materials**

You can build this desk with the following inexpensive materials:

### 1. **Wood**

- Solid Core Door, 80 by 28 inches, 1 ----- \$ 44.00
- .5 by .75 inch wooden Molding, 26 feet, \$.32/foot -- \$ 10.00
- 1 by 4 pine boards, \$.65/foot ----- \$ 32.00
- 1/4 inch plywood, 18 by 32 inches ----- \$ 4.00

### 2. **Hardware**

- 4 d finishing nails, 1 pound ----- \$ 1.50
- 1-1/4 inch #8 flat head screws, 16 -- \$ 1.50
- 5/8 inch brads, 1 box ----- \$ 1.50
- 3 inch angle braces, 4 ----- \$ 7.00
- Heavy duty Drawer Guide, 1 set ----- \$ 16.00

- Feet, set of 4 ----- \$ 3.00
- Eye Screws, package ----- \$ .75
- 3/4 inch #6 pan head screws, 8 ----- \$ .75

### 3. **Other Materials**

- Wood Glue 8 oz. ----- \$ 3.00
- Stain ----- \$ 8.00
- Polyurethane Varnish ----- \$ 9.00

### 4. **Omissions and Contingencies**

- Allow %15 for tax, sandpaper etc. -- \$ 21.50

### 5. **Total -- \$ 160.00**

The secret is to get a good price on the filling cabinet.

## 4. **Tools Required**

You will need the following tools:

### 1. **Saw and Miter Box**

A small hand saw and miter box are needed. The cost new is about \$20.00.

### 2. **Drill**

This can be a hand drill or a small power drill. You can use cut off nails for the bits.

### 3. **Screw Driver**

The angle brackets and drawer guides usually have Phillips head screws.

### 4. **Hammer**

You need a common claw hammer. A small point nail set also helps.

## 5. **Square**

You need a simple square.

## 5. **Construction Notes**

### 1. **Cutting the Molding**

You use .5 by .75 inch molding to position the filing cabinets, keep the desk top from crushing the cable against the wall, and to frame the drawer. It is commonly available as it is used in sash windows. Using this material means you do not have to have any kind of power saw to make this desk.

The molding is easiest cut with a miter box and small hand saw. These cost about \$10.00 each new. All the cuts are either 90 degree or 45 degree. Be careful to note if the 45 degree cuts are on the .5 inch or the .75 inch side.

### 2. **Door**

The door normally used for this desk is a 'Solid Core' door. These cost about \$20.00 more and are much heavier than the 'Hollow Core' door but you can saw them off at the required angles. The sawn edge will be end-grain and may have gaps.

You can also get these doors either covered in inexpensive hardwood or masonite. The hardwood is bland but looks nice if stained and varnished.

### 3. **Cutting the Door**

Decide how big you want the desk. The drawing shows it at about the maximum length. You can make it smaller by cutting more desk off. If you make the desk too small you will have problems fitting a decent keyboard drawer.

You can often have this cut made at the place where you buy the door but you must know the exact length of desk you want before you go to buy the door. Also they may not be able to cut the 45 degree angles.

This cut is best done with a power saw running against a straight edge. You must use a

plywood blade with many teeth. The blade should just come through the door. To reduce splintering try placing masking tape on both sides of the door, then marking on it, and cutting through it.

#### 4. **Legs**

The leg pieces can be cut to length with the miter box and hand saw. One piece needs to be notched. The inside board serves to mount one side of the keyboard drawer guide. The length of the four leg pieces may need to be adjusted to exactly suit your table top. Be sure to consider the feet in making your measurement. The leg assembly is held together with nails and glue.

#### 5. **Drawer**

If you are cutting the door off to fit your floor space, you may need to size the keyboard drawer to fit. The piece sizes shown in Sketch #3 are for a full size drawer. The easiest thing to do is to cut the pieces to the lengths shown then shorten pieces 1, 2, 5, 6, and 7.

Install two angle brackets to the inside of the leg assembly and two to one separate hanger board. The brackets should be only a 1/4 inch in from the edge so that they will catch good wood.

Stand the leg assembly on the door about 1/4 inch in from the good end. Trial fit the drawer slide and back drawer piece (5) between the hanger board and the leg assembly. Determine if you need to cut it off. Trim pieces 1, 2, 6, and 7 by the same amount. Be careful to cut the bottom square.

Pre-drill nail holes in the pieces. Glue and nail the front, back, and two sides into the 'L' shape shown in the cross section. The paired pieces are not the same length but the short one should always be centered on the longer one.

Cut the four short beveled pieces about 3 inches long. These look like the position blocks but they are cut with the 45 the other way. Pre-drill these blocks too.

Assemble the four sides around the plywood base. Be careful to make the drawer square. The Bottom is held in with glue and brads. The short beveled pieces lock the four corners of the frame.

Trim the front of the drawer to cover the guides but not hit the leg assembly or the hanger board.

## 6. Hanging the Drawer

We suggest you spend some money for a good drawer guide. These have steel balls and do not have plastic wheels. Cheap guides work badly. The good ones are called 'Medium' or 'Heavy' duty and cost about \$8.00 more. You can make a guide out of the same wood molding as the drawer but it does not work as well.

After the drawer glue is dry. Attach the drawer guides to its sides. First use a few screws in slotted holes. Only after adjustment will you add more screws in the round holes.

Attach the drawer slides at the lower edge of the hanger board and the leg assembly. You may have to take the guide apart to do this.

Reassemble the drawer slides and position the drawer and leg piece exactly where you want it on the door. The front of the drawer should line up with the front edge of the door. Drill holes for the back angle bracket screws and install them. Carefully mark the front of the leg piece and remove the drawer from the slide. Check the position of the hangers and install the front bracket screws.

## 7. Adjusting the Drawer

Turn the whole desk over for the first time. Reinstall the drawer into its guides. Check that it runs smoothly and is parallel to the bottom of the door. Tighten all the existing guide screws and add more in round holes. A few extra screws here will keep the drawer running smoothly for a long time. This is particularly important for the Leg Piece where you do not have much material to grip with any one screw.

You will want to cut a 1-by piece of wood the size of your mouse pad to put under it. This brings the mouse up to a more comfortable height.

## 8. Cable Protection Blocks

The two Cable Protection Blocks are cut from the same molding as the Positioning Blocks but have two beveled ends. Pre-drill and nail them to the back edge of the door. These prevent the door from crushing the computer cables against the wall.

If you like, you can add some eye hooks along the back edge of the door. These allow you to tie the computer cables up out of the way.

## 9. Finish the Desk

Hand sand all sharp edges. Spend some time on the front edges of the keyboard drawer so that the edges feel comfortable in you hand. Round the four door corners a little too.

The door is usually simply hand sanded, stained, and covered with two coats of polyurethane varnish. Several applications of stain may be needed to get the edges of the door to be as dark as the top.

Everything below the desk top is usually stained or painted a dark color.

## **Conclusion**

Congratulations, you have complete a good, low-stress computer desk. The desk you made could easily be in use by a series of students for many years.