

37 CORNER CABINET



Skills needed include using a circular saw. Definitely not one for beginners! Remember to allow for the room's skirting board – the top section of the cabinet will be set further into the corner than the bottom. Our cutting diagram (Figure I) allows for this

THE BOTTOM CABINET

1. Mark out the plan or template as shown in Figure I (diagram 1). It's essential to be accurate with the complex angles that occur. As you proceed, check all the components against this plan. Glue and screw all the joints.
2. Screw the two backs together at the rear corner. Position the cabinet floor in place, 90mm up from the bottom, using its 90-degree corner to set the backs at the same angle relative to one another.
3. The top rail is made of three pieces screwed together to negotiate the front corners (see Figure I, diagram 1). Making this is the most complex section of the project. Notches are cut out of the front corners to accommodate the vertical hinging rails. The top rail is screwed into place, checking that the structure remains square. The second purpose of the top rail is to make the cabinet structurally sound, without its two side panels. This makes the installation procedure simpler and allows you to shape the side panels into the wall, allowing the cupboard to be a perfect fit regardless of irregularities in the wall surface.
4. Cut out the hinging rails, noting that they stop at the cupboard bottom. Use 42mm x 19mm radiata pine with a 67-degree chamfer, where they abut the sides. Check the top and bottom hinges; screw them in place. Add a 67-degree chamfer to the corner edge of the sides before screwing them in place temporarily.
5. Screw down through the floor into the bottom rail which is a single timber component mitred to the sidewall angle at each end.
6. Position the top using angle brackets, screwed in place from the inside and hinge the doors in place.

THE TOP SHELVES

7. Screw the two backs together and brace them against one another, using one of the triangular shelves as the top.
8. Include another fixed shelf halfway down the backs. These two will be sufficient bracing and all other shelves will be adjustable.
9. Screw the side fascias in place.

Materials for bottom cabinet:

Component	Material	Length/size
Back (1 of each size)	18mm thick MDF	882mm x 800mm 882mm x 782mm
Bottom: shelf (2) sides (2)	18mm thick MDF	960mm right-angle triangle 882mm x 200mm
Rails: top/bottom (2) side (2)	45 x 35mm pine	850mm 250mm

Hinging cleats (2)	42 x 19mm pine	754mm
Skirting: sides (2)	90 x 19mm pine	225mm
front (1)		850mm
Top (1)	18mm thick MDF	1060mm right-angle triangle
Doors (2)	9mm thick MDF 13mm thick lining boards	755mm x 390mm

Materials for top shelving

Component	Material	Length/size
Backs (1 of each size)	16mm thick MDF	1740mm x 665mm 1740mm x 649mm
Shelves/top (3)	18mm thick MDF	645mm right-angle triangle
Fascia (2)	18mm thick MDF	1740mm x 150mm
Cornice (1)	78mm pine cornice moulding	1100mm

Other materials: 50mm particle-board screws; wood glue; 35mm brass butt hinges (4); magnetic door catches (2); 19mm scotia for trimming.

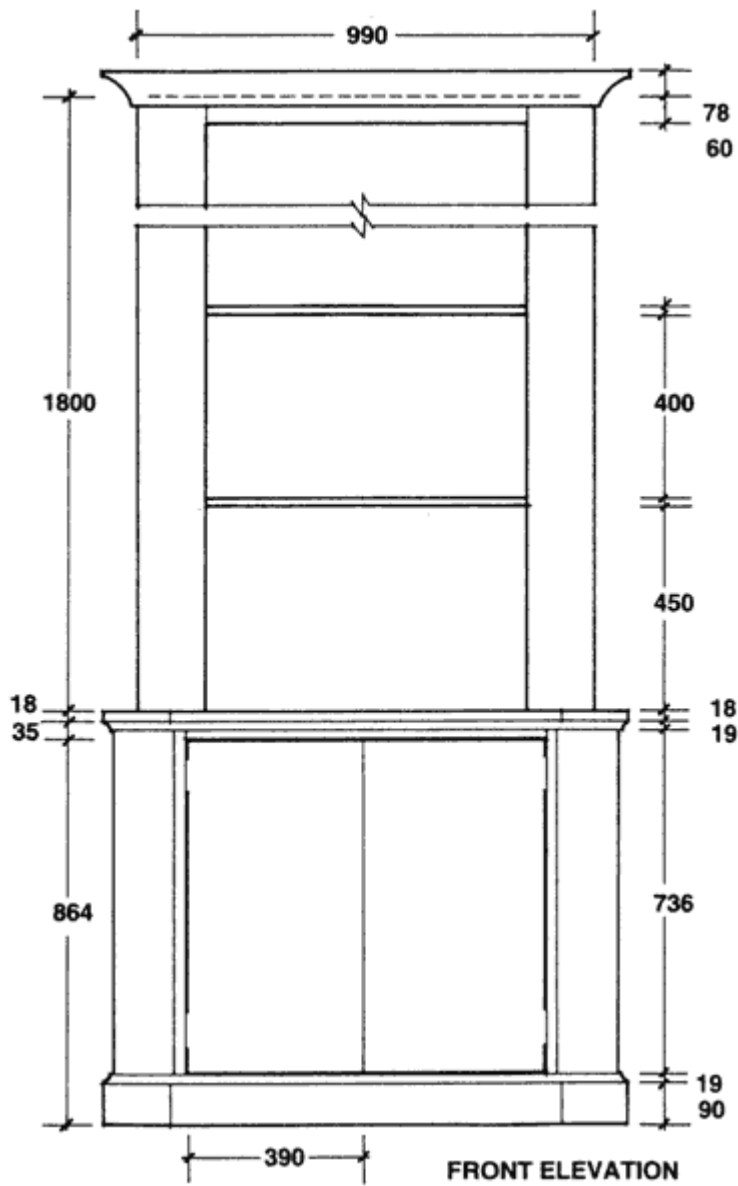

DIAGRAM 1 (cutting diagram)

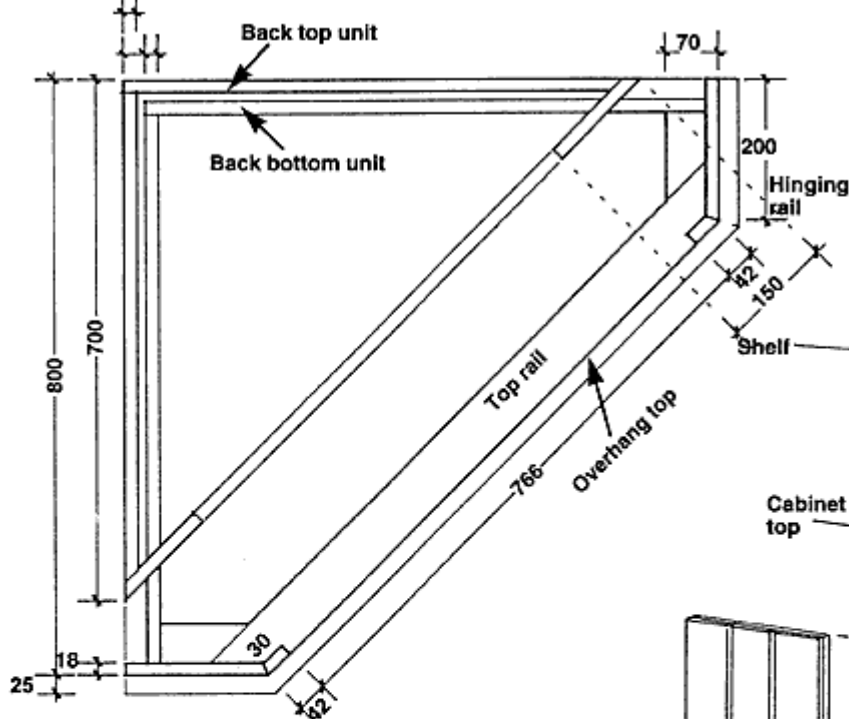
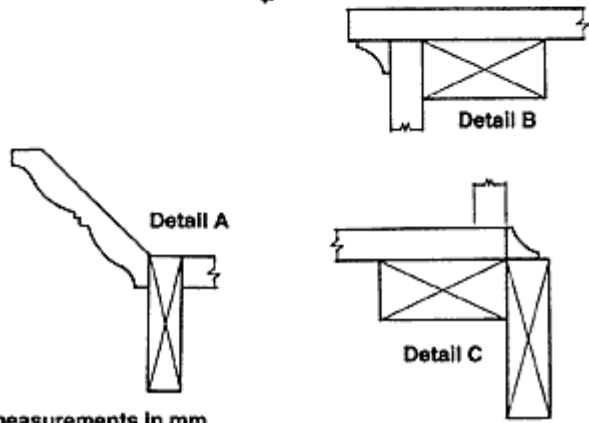
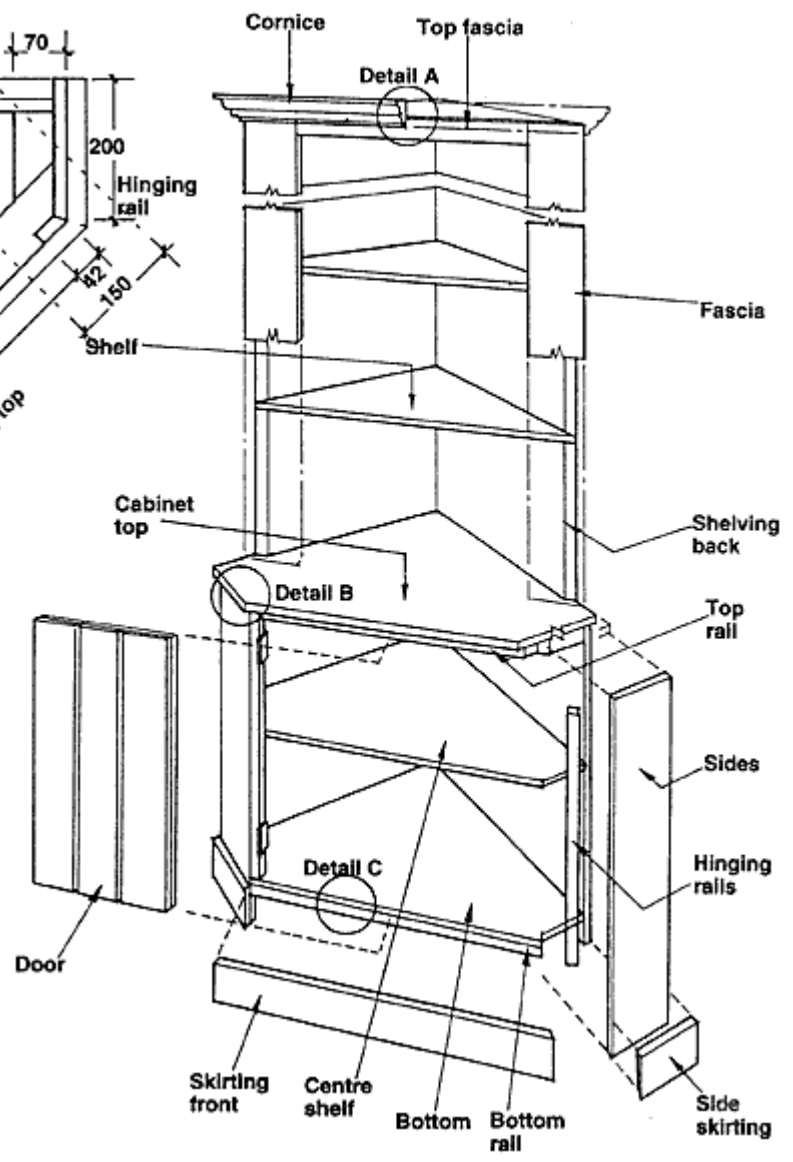

DIAGRAM 2



All measurements in mm