



Wow! I Made It.com

## Occasional Table

*Everyone can use an extra table somewhere in the house, and because this occasional table is only 21" high and about 24" square, it will fit almost anywhere, too. If you have enough space, make a couple of these tables and place them side-by-side to create a good-looking coffee table.*



## **Special Tools and Techniques**

- Bar clamps
- Mitering

## **Materials and Supplies**

- 18 linear feet of 1 x 4 pine
- 7 linear feet of 1 x 6 pine
- 1 piece of laminated pine, 17" x 17"
- 4 table legs, each 20" long

## **Hardware**

- Approximately 40 #6 x 1-1/4" flathead wood screws
- Approximately 8 # 10 x 3" flathead wood screws

## **Cutting List**

Code	Description	Qty.	Material	Dimensions
A	Center Top	1	Laminated pine	17" x 17"
B	Top Trim	4	1 x 4 pine	24" long
C	Long Base	2	1 x 6 pine	24" long
D	Short Base	2	1 x 6 pine	13" long
E	Leg	4	Purchased	20" long
F	Rail	4	1 x 4 pine	Cut to fit, (approx. 16-3/4" long)
B	Corner Support	4	1 x 4 pine	10" long

## **Notes on Materials**

The center top (A) of this occasional table is made from laminated pine boards. Most building-supply stores sell sections of wood that have already been laminated. You can laminate the boards yourself, of course, but we don't recommend doing so unless you're an experienced woodworker and own the necessary tools. The monetary savings aren't that significant, and you'll save a lot of time by purchasing the laminated pine.

If you don't have a lathe or don't want to turn the legs yourself, just purchase four turned legs from a building-supply store. The shape of the legs isn't important, but the four faces at the top of each one must be flat in order to provide proper connections for the rails that abut them.

## Constructing the Table Top

1. Cut one 17" x 17" center top (A) from laminated pine.
2. Cut four 24"-long top trim pieces (B) from 1 x 4 pine.
3. Set each top trim piece (B) on its face and miter each end of all four pieces at a 45-degree angle, as shown in *Figure 1*. When you're finished, one edge of each top trim piece should be 17" long and the opposite edge should be 24" long.
4. Glue and clamp the top trim pieces (B) to the edges of the table top (A) and leave the assembly undisturbed for at least 24 hours. The framed top should measure 24" x 24".

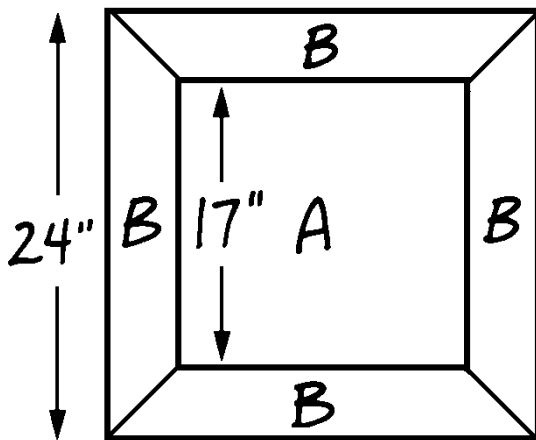

Figure 1

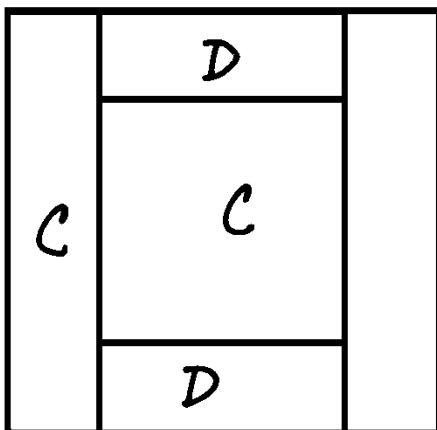

Figure 2

## Constructing the Base Frame and legs

1. Cut two long base pieces (C) from 1 x 6 pine, each 24" long.
2. Cut two short base pieces (D) from 1 x 6 pine, each 13" long.
3. To assemble the base frame, place the two long base pieces (C) on a level surface, parallel to each other and 13" apart. Place the two short base pieces (D) between the long base pieces (C) to form a 24" x 24" square, as shown in *Figure 2*. Glue and clamp the four pieces together. Leave the assembly undisturbed for at least 24 hours.
4. To add the four 20"-long legs, you must first center each one in a corner of the base frame. To locate the center point for a leg, draw a line across a long base piece (C) 5-1/2" from the end, as shown in *Figure 3*, to form a 5-1/2" x 5-1/2" square. Then draw two lines to connect that square. The intersection of these two lines is the center point for the leg.
5. Most purchased legs come with a metal screw in the center of the top of the leg. At the marked center point on the long base (C), drill a

hole slightly smaller in diameter than the metal screw. Apply glue to the meeting surfaces and hand-screw the leg (E) into the drilled hole. Make certain that the leg is positioned so that the flat faces at its top are parallel to the edges of the table.

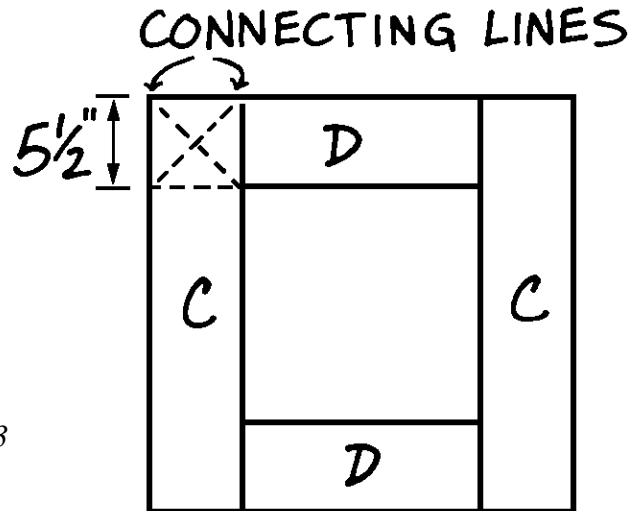

Figure 3

6. Repeat Step 5 to attach the remaining three legs (E) to the other three corners of the base frame.
7. Make certain that all four legs (E) are perfectly straight. Then let the assembly dry overnight until the glue sets.
8. To reinforce the leg joints, turn the base assembly right-side up. Insert two 3" screws through each long base (C) and into each leg (E).

### **Adding the Rails**

1. Before cutting the four rails (F) from 1 x 3 pine, measure the distance between each set of table legs. This measurement will vary, depending upon the diameter of the legs you purchased. Then cut each rail piece (F) to that length.
2. Glue one rail (F) between each set of two adjacent legs (E), as shown in *Figure 4*. Then insert 1-1/4" screws, spaced 6" apart, through the long bases (C) and short bases (D) and into the edges of the rails (F).
3. Cut four 10"-long corner supports (G) from 1 x 4 pine. Set the corner supports on their faces and miter the ends of each one at 45-degree angles.
4. To further reinforce the rails (F) and legs (E), glue a corner support (G) between each set of two rails (F), as shown in *Figure 4*. Insert 1-1/4" screws through the corner support and into the base frame.

## Adding the Table Top

1. Place the center top (A) and attached trim pieces (B) upside down on a level surface.
2. Center the base assembly over the top assembly, so that the sides of the assemblies are exactly flush (see *Figure 4*). Glue the assemblies together and insert 1-1/4" screws, spaced 6" apart, through the long and short base pieces (C and D) into the top assembly.

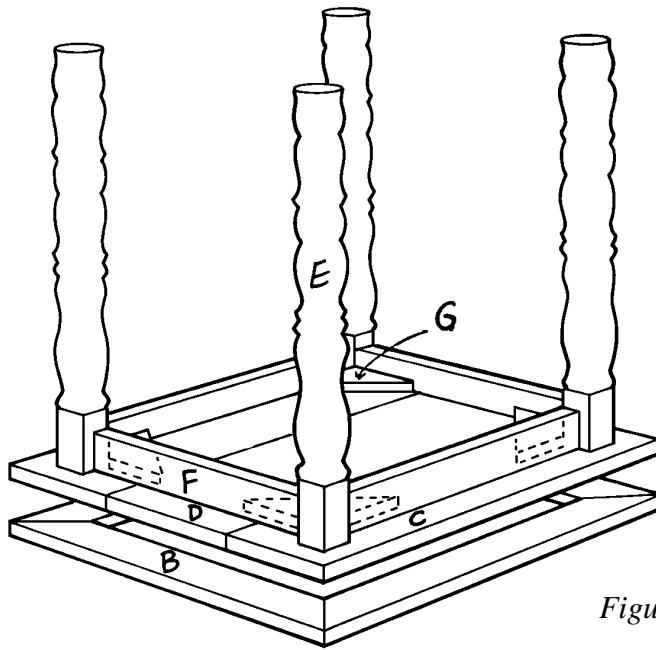

Figure 4

## Finishing

1. Fill any cracks, crevices, or screw holes with wood filler. Then sand all surfaces of the occasional table thoroughly.
2. Paint or stain the completed project the color of your choice.



Try other indoor and outdoor projects from [\\_\\_\\_\\_\\_](#) !