

PLEASE READ THROUGH ENTIRELY
 THESE PLANS ALLOW YOU TO BUILD ON
 A CONCRETE SLAB, A WOODEN FLOOR
 SUPPORTED BY CONCRETE PIERS, OR A WOODEN
 FLOOR SUPPORTED ON SKIDS SEE OUR FREE ON
 LINE CONSTRUCTION GUIDE FOR MORE DETAILS

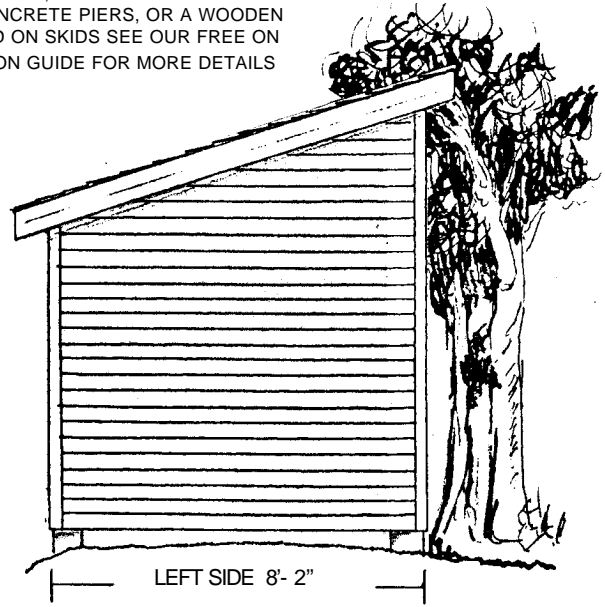

WALL AND FLOOR
 HEIGHT 8'-8"

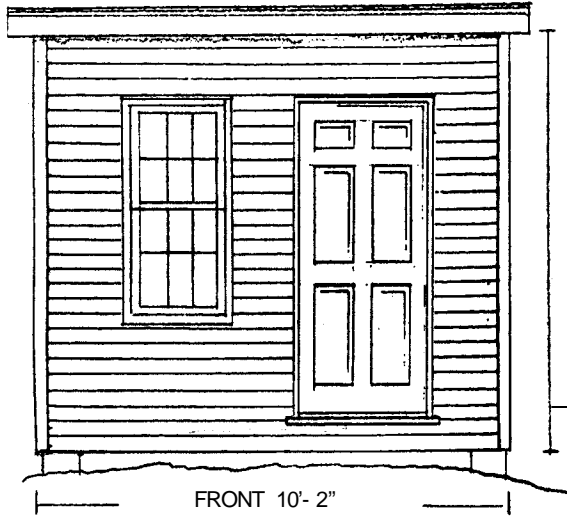
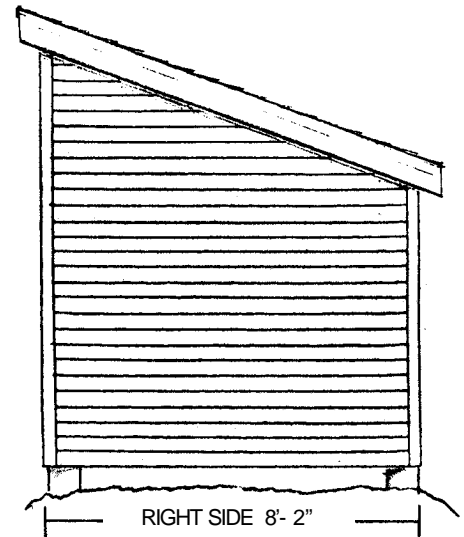

WALL AND FLOOR
 HEIGHT 6'-0"

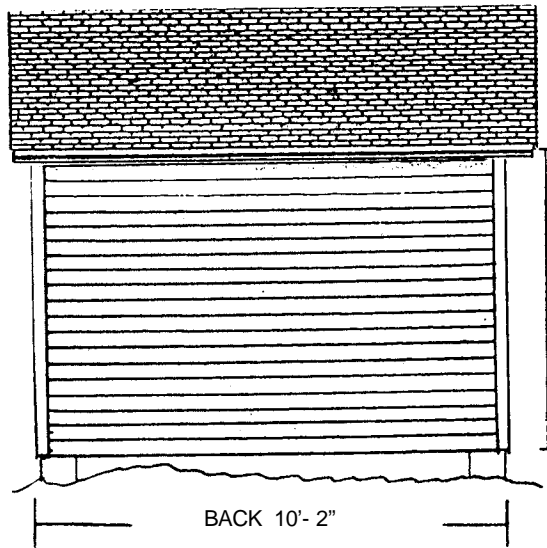

CONTENTS

PAGE 1	ELEVATIONS
PAGE 2	CROSS SECTION 1
PAGE 3	FLOOR PLAN
PAGE 4	CONCRETE PAD
PAGE 5	SKID FOUNDATION
PAGE 6	CROSS SECTION 2
PAGE 7	LEFT WALL DETAILS
PAGE 8	RIGHT WALL DETAILS
PAGE 9	FRONT WALL DETAILS
PAGE 10	BACK WALL DETAILS
PAGE 11	RAFTER PLACEMENT
PAGE 12	RAFTER CUTTING
PAGE 13	SPECIFICATIONS
PAGE 14	MATERIAL LIST
PLUS 2	TEMPLATES

SOME E-MAIL SOFTWARE MAY
 CHANGE SCALES SLIGHTLY

**THESE PLANS ARE FOR
 PERSONAL USE ONLY**

© 2002 Just Sheds Inc.
 All rights reserved

ELEVATIONS
 SCALE
 $\frac{1}{4} = 1'-0"$
 DRAWN
 JUNE 2005
 SIZE
10'X8'
PLAN
FREE

3/8" PLYWOOD SHEETING
SUPPORT EDGES WITH H CLIPS
2"X 4" ROOF RAFTERS 16" O. C.

4/12" ROOF PITCH

3-TAB ASPHALT
ROOF SHINGLES

METAL CAP FLASHING

2"X 5" FASCIA BOARD
6" VINYL FASCIA

VENTED SOFFIT ALL AROUND

6" UNIFORM ROOF
OVERHANG

FRONT
WALL
HEIGHT
8' - 0"

4" VINYL SIDING

15 ASPHALT PAPER OVER-
LAPPED
TO SHED WATER

NOTE
FILLING THE CONCRETE
BLOCKS BELOW WILL
HELP PREVENT WATER
FROM COLLECTING
AND DAMAGING THE
BLOCK DURING ANY
FREEZE THAW CYCLES

7/16" ASPENITE INTERIOR SHEETING
WALL SHEETS WILL SUPPORT THE
EDGES OF CEILING SHEETS WHEN
INSTALLED AS SHOWN

5/8" TONGUE AND
GROOVE PLYWOOD

2"X 4" WALL STUDS 16" O.C
7/16" ASPENITE SHEETING OVER

2"X 8" FLOOR JOIST 16" O.C.
USE JOIST HANGERS AS SHOWN
USE DOUBLE JOIST UNDER
SIDE WALLS

3-PC 2"X 8" BUILT UP BEAM

3" STEEL SADDLE ANCHOR

FILL ANY SPACE UNDER
BEAM OR DOUBLE JOIST
WITH MORTAR

SIDING TO COVER
CONCRETE BY 1/2"

KEEP ALL WOOD AT LEAST 6 INCHES ABOVE GRADE

8" CONCRETE BLOCK FILLED
WITH CONCRETE OR 10"X 12"
SOLID CONCRETE PIER

RECOMMENDED FOUNDATION
25"X 25"X 6" CONCRETE
FOUNDATION INSTALLED ON
UNDISTURBED SOIL BELOW
KNOWN FROST PENETRATION

CROSS
SECTION 1
1" = 1'- 0"
SIZE
10'X8'
PLAN
FREE

ANCHOR BOLTS
 IF YOU CHOOSE TO BUILD ON A CONCRETE PAD PLACE 1 ANCHOR BOLT NEAR EACH END OF THE RIGHT AND LEFT WALLS AND 3 EACH IN THE BACK & FRONT WALLS (TOTAL OF 10 BOLTS)

TYPICAL 25"X 25"X 6" CONCRETE FOUNDATION
 8" BLOCK, 3" SADDLE ANCHOR, 3-PC 2"X 8" BUILT UP BEAM

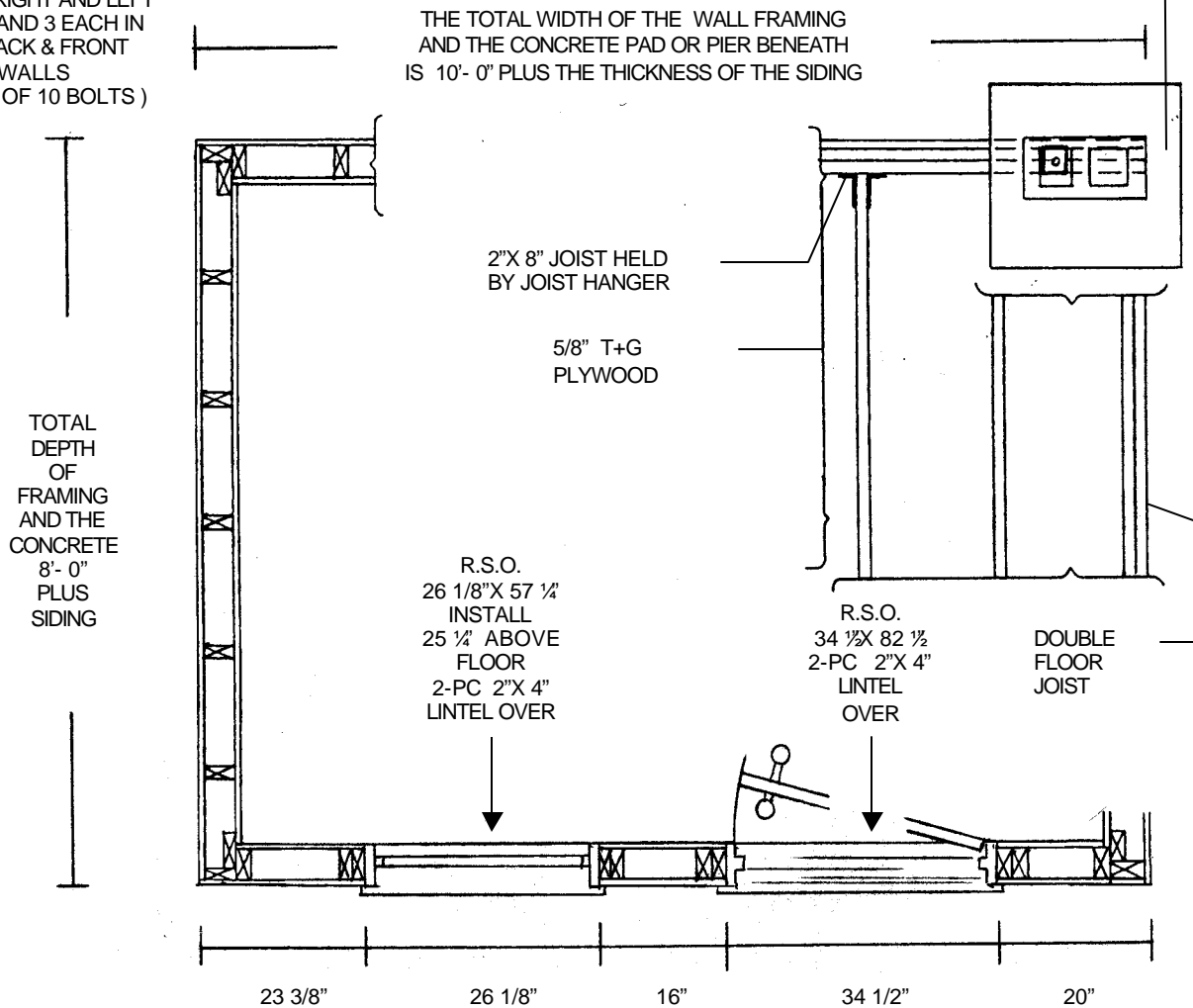

LUMBER CUTTING LIST FOR THIS FLOOR

DESCRIPTION	SIZE	LENGTH	QUAN	NOTES
3 PC. BEAM	2X8	119 1/8"	6	USE 3 PC. FOR EACH SIDE
JOIST	2X8	86 1/8"	11	

For more information on cutting lumber see section 4 of our Construction Guide.

NOTE

2X8 floor joists are recommended for this shed to achieve a 40 lbs live load rating. Which is similar to homes.

Whether you need a shed for growing plants, a place for youngsters to play and build lifelong memories or just a place for the lawn equipment; we have the plans for you. With all our styles and sizes combined, we have over 120 plans to choose from. Whether the shed captures the charm of New England or one that utilizes maintenance-FREE materials, when you need more space think of us and visit our family of web sites.

FLOOR PLAN SCALE 1/2" = 1'- 0" SIZE 10'X8' PLAN FREE

We have the world's largest collection of shed plans.

Some common words and phrases used in our plans and specifications may be unfamiliar to you in your area. This is because of different trade names used by different manufacturers. Suppliers in your area will know of a similar and equivalent product.

See the Glossary of Terms in our online free Construction Guide for more details.

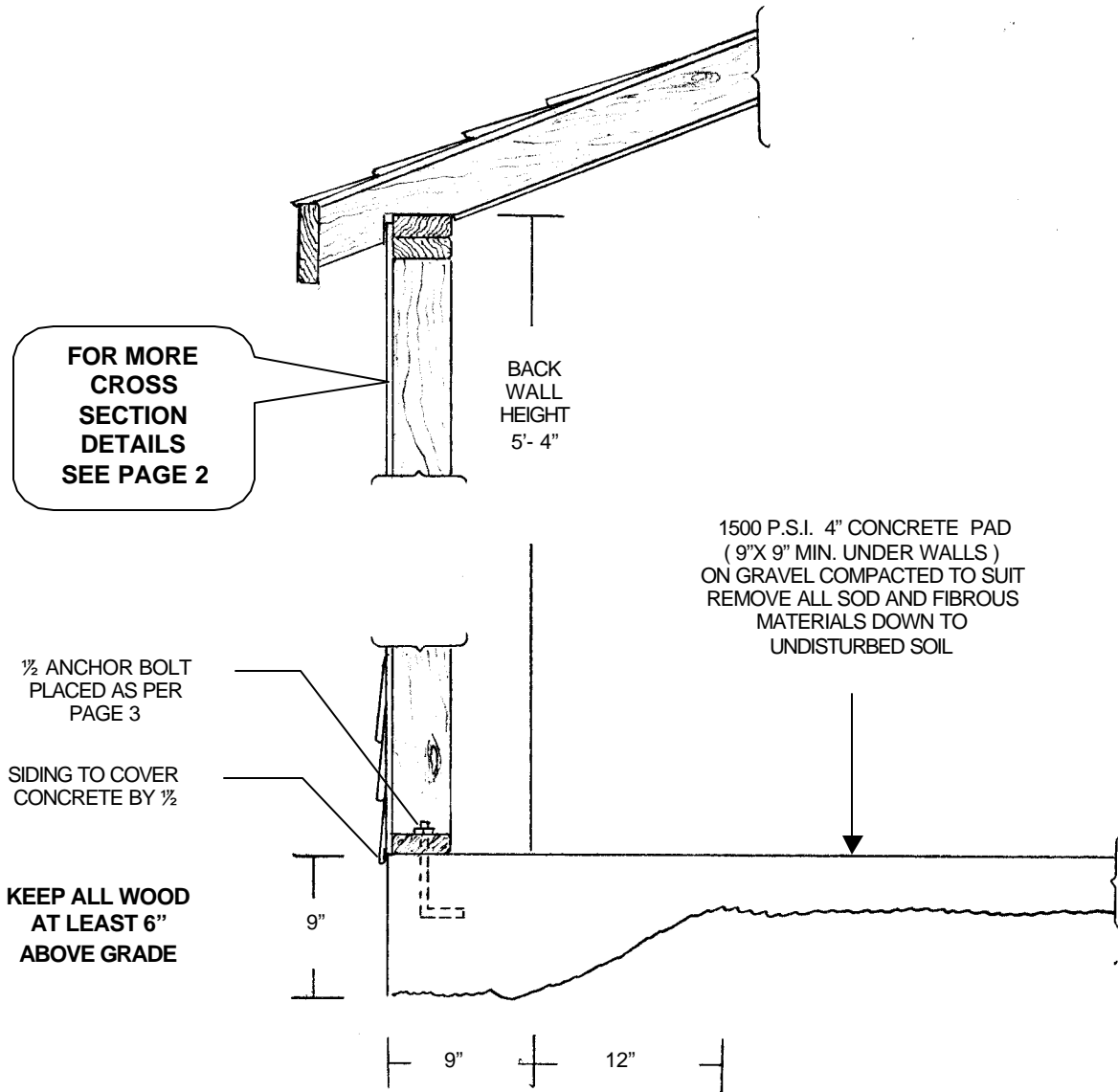

Choosing to build your shed on a concrete pad will change the appearance. Compared to the wooden-floor version shown on page 1, the version shown here uses about 8 inches of siding less than the other.

*We appreciate and
Thank you for all
Your referrals*

**CONCRETE
PAD
1" = 1'- 0"
SIZE
10'X8'
PLAN
FREE**

FREE CONSTRUCTION GUIDE

Use our easy to read, printable free Construction Guide designed for the do-it-yourselfer.

It was written exclusively for all of our shed plans.

With text and lots of illustrations it deals with interesting professional wood framing techniques, the three kinds of foundations that many of our plans use and much more.

Check it out and...

DISCOVER WHAT WE WILL HELP YOU BUILD.



NOTE

WHEN THE REQUIRED 7/16" WALL SHEETING IS INSTALLED OVER THE JOIST FRAMING IT BECOME THE SIZE AS SHC THE FLOOR PLAN

MAKE THE TOTAL DEPTH OF FLOOR JOIST FRAMING 7'-11 1/8"

MAKE THE TOTAL WIDTH OF FLOOR JOIST FRAMING 9'-11 1/8"

TYPICAL 2X6 FLOOR JOIST INSTALL 16" O.C. NAILED TO EACH 6X6 SKID AND TO THE HEADER JOIST AT EACH END USING 3, 3 1/2 NAILS AS OUTLINED IN THE SPECIFICATIONS ITEMS 12, 13 AND 16. BEFORE INSTALLING THE PLYWOOD MOVE A SKID BACKWARDS OR FORWARDS SO THAT THE FRAME IS COMPLETELY SQUARE

TYPICAL 6"X6" WOODEN PRESSURE TREATED SKID LAID ON LEVEL COMPACTED GRAVEL BED (SEE CROSS SECTION 2) CUT SKID 3" SHORTER THAN JOIST FRAMING. INSTALL 1 1/2" IN AT THE SKIDS' END AND 6" IN FROM IT'S SIDE

NOTE

Here the shorter joist span calls for 2X6 floor joists to achieve a 40 lbs live load rating. Which is similar to homes.

TYPICAL 2X6 HEADER JOIST

2X6 SOLID BRIDGING STAGGER FOR EASIER NAILING

TYPICAL DOUBLE 2X6 FLOOR JOIST AT EACH END

LUMBER CUTTING LIST FOR THIS FLOOR

DESCRIPTION	SIZE	LENGTH	QUAN	NOTES
BEAM	6X6	116 1/8"	2	
HEADER JOIST	2X6	119 1/8"	2	
JOIST	2X6	92 1/8"	11	
BRIDGING	2X6	14 1/2"	7	
BRIDGING	2X6	?	1	CUT THE LAST ODD PIECE TO SUIT

For more information on cutting lumber see section 4 of our Construction Guide.

SKID FOUNDATION SCALE
3/8" = 1'-0" SIZE
10'X8' PLAN FREE

**KEEP ALL UNTREATED WOOD AT
LEAST 6 INCHES ABOVE GRADE**

THE ROOF RAFTER ENDS MUST REST ON
THE WALLS THAT HAVE THE 6" X 6" SKID 6"
AWAY. NOT ON THE WALL WITH THE
DOUBLE FLOOR JOISTS UNDER THEM

TYPICAL 2X6 FLOOR JOIST
5/8" PLYWOOD OVER

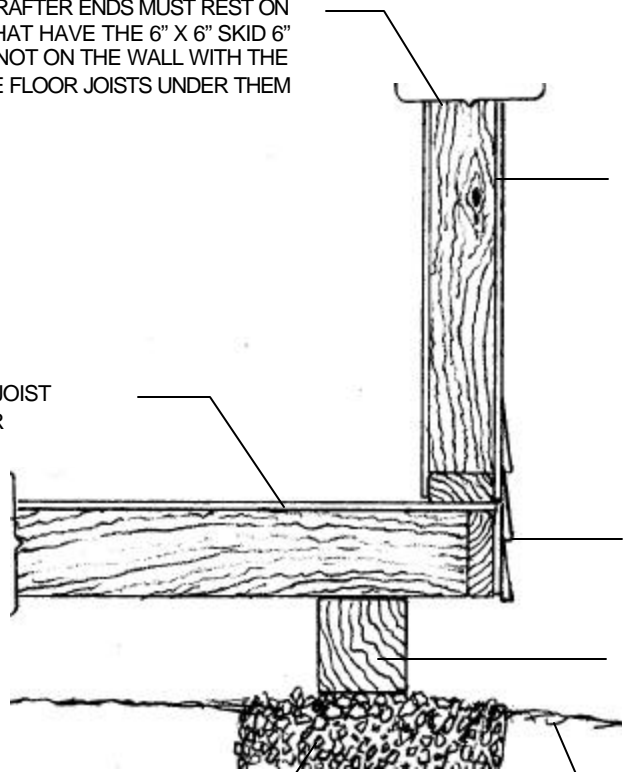

2"X 4" WALL STUDS 16" O.C
7/16" ASPENITE SHEETING OVER

HORIZONTAL OR VERTICAL VINYL
SIDING AS SHOWN ON PAGE 1

TYPICAL 6"X6" WOODEN
PRESSURE TREATED SKID
LAID ON LEVEL COMPACTED
GRAVEL BED 6" IN FROM WALL

MINIMUM 6" X 18" LEVEL COMPACTED
GRAVEL BED. REMOVE ALL SOD AND
FIBROUS MATERIALS DOWN TO
UNDISTURBED SOIL

TYPICAL GRADE.
GRADE SO THAT ALL WATER
DRAINS AWAY FROM SHED.



Join the tens of thousands who have used
our shed plans throughout the world.



Visit our family of web sites to get your free catalog of shed plans

**CROSS
SECTION 2
SCALE
1" = 1'- 0"
SIZE
10'X8'
PLAN
FREE**

STEPS FOR WALL FRAMING AND LUMBER CUTTING

- 1ST Cut and layout at 16" O.C. the BP1 for studs starting from the right.
- 2ND Cut and layout TP1 for studs at 16 7/8" O.C. starting at S9
- 3RD Cut and nail all of the studs to BP1.
- 4TH Nail TP1 to the studs in place, install wall sheathing as advised in the Construction Guide and finish nailing as per specifications

NOTE! The 90° angle cuts needed are not listed in the angle column. The lengths mentioned here, when there is an angle cut, are always measured at the longest points. When there is a second figure in the angle column, it is for the bottom or the right end that needs to be cut.
 For more information on cutting lumber see section 4 of our Construction Guide.
 FOR CLARITY ON ANGLE CUTTING ORIENTATION SEE THE RAFTER CUTTING PAGE

DESCRIPTION	CODE	USE	CUT LENGTH	QUAN.	ANGLE	NOTES
BOTTOM PLATE	BP1	2X4	95 1/8"	1		
TOP PLATE	TP1	2X4	101 1/4"	1	19°/19°	Cut as shown
WALL STUD	S1	2X4	60 3/8"	1	19°	Cut as shown
WALL STUD	S2	2X4	61 1/2"	1	19°	Cut as shown
WALL STUD	S3	2X4	65"	1	19°	Cut as shown
WALL STUD	S4	2X4	70 5/8"	1	19°	Cut as shown
WALL STUD	S5	2X4	76 1/8"	1	19°	Cut as shown
WALL STUD	S6	2X4	81 3/4"	1	19°	Cut as shown
WALL STUD	S7	2X4	87 1/2"	1	19°	Cut as shown
WALL STUD	S8	2X4	92 1/2"	1	19°	Cut as shown
WALL STUD	S9	2X4	93 1/8"	1	19°	Cut as shown



TYPICALLY SPACED WALL STUDS 16 7/8" O.C. ALONG THIS ANGLED TOP PLATE, WHICH WILL ALIGN WITH 16" O.C. ON THE BOTTOM PLATE

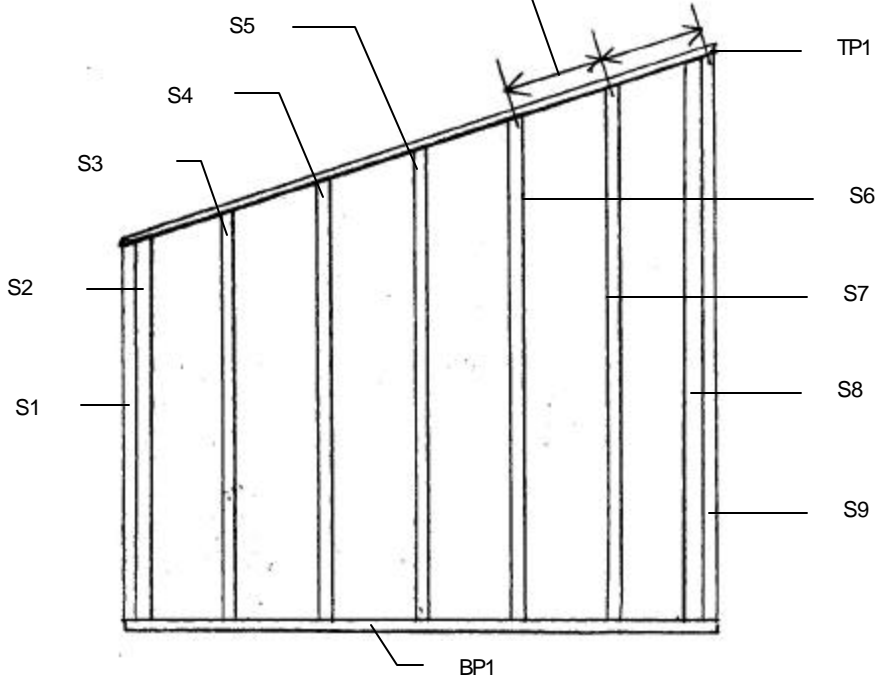

WALL BUILDING STEP # 1

THE SECTION OF WALL SHOWN HERE IS WITHOUT SHEETING TO AID IN ILLUSTRATION. FOR THIS SHED PLAN IT IS RECOMMENDED THAT IT BE BUILT ON THE FLOOR FIRST AS BUILDING STEP NUMBER 1 OF 4 PUT ASIDE AND INSTALLED LATER AS INSTALLATION STEP NUMBER 2 OF 4. WITH SHEETING IT WILL WEIGH ABOUT 110 LBS.

**LEFT SIDE
WALL DETAILS**
 SCALE
 3/8" = 1'- 0"
 SIZE
10'X8'
 PLAN
FREE

STEPS FOR WALL FRAMING AND LUMBER CUTTING

- 1ST Cut and layout at 16" O.C. the BP1 for studs starting from the left.
- 2ND Cut and layout TP1 for studs at 16 7/8" O.C. starting at S9.
- 3RD Cut and nail all of the studs to BP1.
- 4TH Nail TP1 to the studs in place, install wall sheeting as advised in the Construction Guide and finish nailing as per specifications.

DESCRIPTION	CODE	USE	CUT LENGTH	QUAN.	ANGLE	NOTES
BOTTOM PLATE	BP1	2X4	95 1/8"	1		
TOP PLATE	TP1	2X4	101 1/4"	1	19°/19°	Cut as shown
WALL STUD	S1	2X4	60 3/8"	1	19°	Cut as shown
WALL STUD	S2	2X4	61 1/2"	1	19°	Cut as shown
WALL STUD	S3	2X4	65"	1	19°	Cut as shown
WALL STUD	S4	2X4	70 5/8"	1	19°	Cut as shown
WALL STUD	S5	2X4	76 1/8"	1	19°	Cut as shown
WALL STUD	S6	2X4	81 3/4"	1	19°	Cut as shown
WALL STUD	S7	2X4	87 1/2"	1	19°	Cut as shown
WALL STUD	S8	2X4	92 1/2"	1	19°	Cut as shown
WALL STUD	S9	2X4	93 1/8"	1	19°	Cut as shown

2

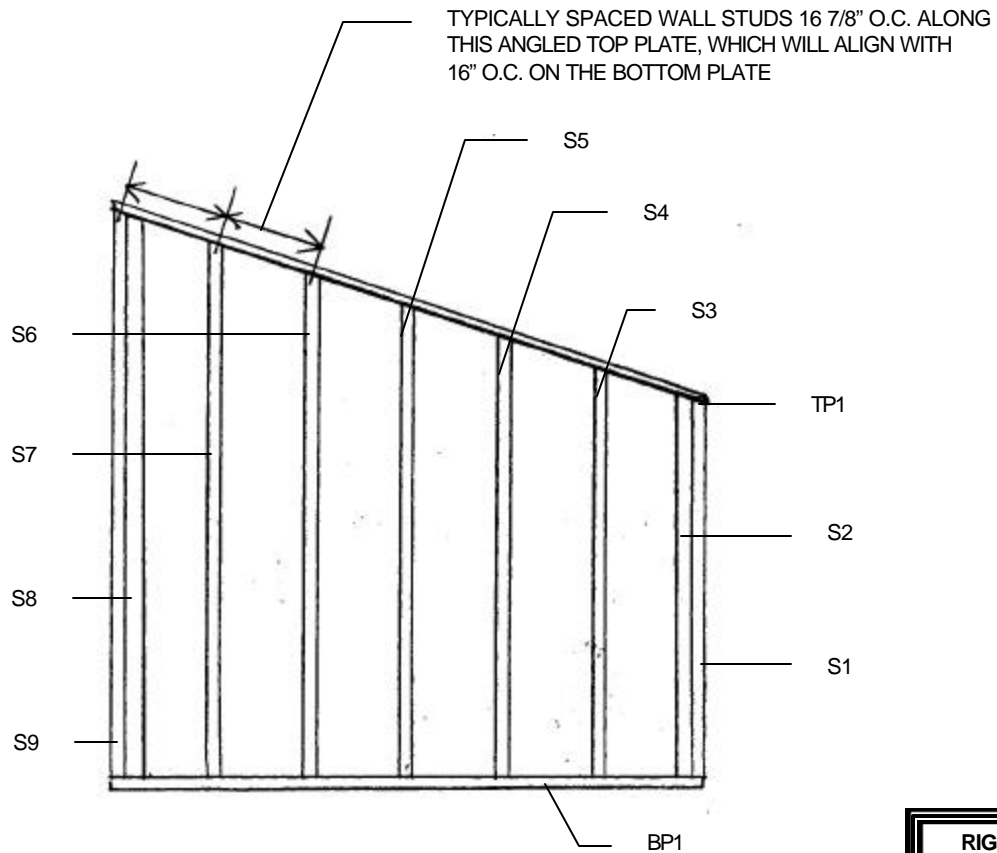

WALL BUILDING STEP # 2

THE SECTION OF WALL SHOWN HERE IS WITHOUT SHEETING TO AID IN ILLUSTRATION. FOR THIS SHED PLAN IT IS RECOMMENDED THAT IT BE BUILT ON THE FLOOR AS BUILDING STEP NUMBER 2 OF 4 PUT ASIDE AND INSTALLED LATER AS INSTALLATION STEP NUMBER 4 OF 4. WITH SHEETING IT WILL WEIGH ABOUT 110 LBS.

**RIGHT SIDE
WALL DETAILS**
SCALE
3/8" = 1'- 0"
SIZE
10'X8'
PLAN
FREE

STEPS FOR WALL FRAMING AND LUMBER CUTTING

- 1ST Cut and layout BP1 and TP1, for studs and trimmer studs at opening locations (shown on the floor plan) at 16" O.C.
- 2ND Cut and nail studs and trimmer studs to BP1 and then nail the studs to TP1. Cut remaining lumber.
- 3RD Nail in DL1 and WL1 on top of trimmer studs and WS1 in between the window's TS2. Nail on the STP1.
- 4TH Nail the rest of the studs in place, install wall sheathing as advised in the Construction Guide and finish nailing as per specifications page.

DESCRIPTION	CODE	USE	CUT LENGTH	QUAN.	ANGLE	NOTES
BOTTOM PLATE	BP1	2X4	9'-4 1/8"	1		
TOP PLATE	TP1	2X4	9'-4 1/8"	1		
SECOND TOP PLATE	STP1	2X4	9'-4 1/8"	1		
WALL STUD	S1	2X4	91 1/2"	6		
TRIMER STUD	TS1	2X4	81"	2		
TRIMER STUD	TS2	2X4	81"	2		
DOOR LINTEL	DL1	2X4	37 1/2"	2		
WINDOW LINTEL	WL1	2X4	29 1/8"	2		
WINDOW SILL	WS1	2X4	26 1/8"	1		One 2x4 install on the flat side
CRIPPLE STUD	CS1	2X4	7"	3		
CRIPPLE STUD	CS2	2X4	22 1/4"	1		

3

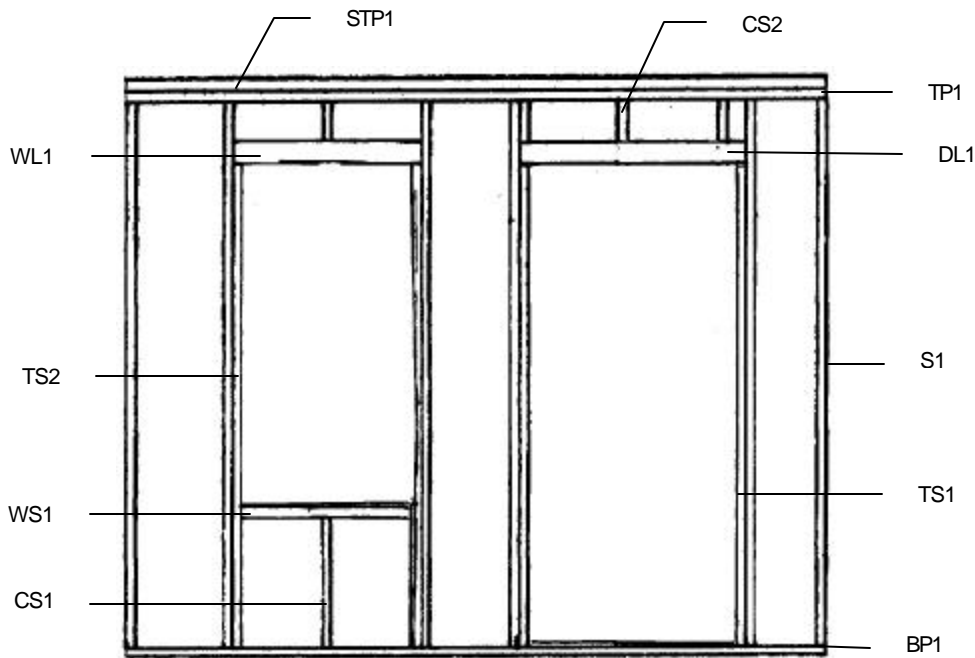

WALL BUILDING STEP # 3

THE SECTION OF WALL SHOWN HERE IS WITHOUT SHEETING TO AID IN ILLUSTRATION. FOR THIS SHED PLAN IT IS RECOMMENDED THAT IT BE BUILT AS BUILDING STEP NUMBER 3 OF 4 AND INSTALLED AS INSTALLATION STEP NUMBER 1 OF 4. WITH SHEETING IT WILL WEIGH ABOUT 110 LBS.

**FRONT WALL
DETAILS**
 SCALE
 3/8" = 1'- 0"
 SIZE
10'X8'
 PLAN
FREE

STEPS FOR WALL FRAMING AND LUMBER CUTTING

- 1ST Cut and layout at 16" O.C. the BP1 and TP1 for studs starting from the right.
- 2ND Cut and nail studs to BP1 and then nail to TP1 and then cut and nail STP1.
- 3RD Install wall sheeting as advised in the Construction Guide and finish nailing as per specifications.

DESCRIPTION	CODE	USE	CUT LENGTH	QUAN.	ANGLE	NOTES
BOTTOM PLATE	BP1	2X4	9'-4 1/8"	1		
TOP PLATE	TP1	2X4	9'-4 1/8"	1		
SECOND TOP PLATE	STP1	2X4	9'-4 1/8"	1		
WALL STUD	S1	2X4	59 1/2"	8		

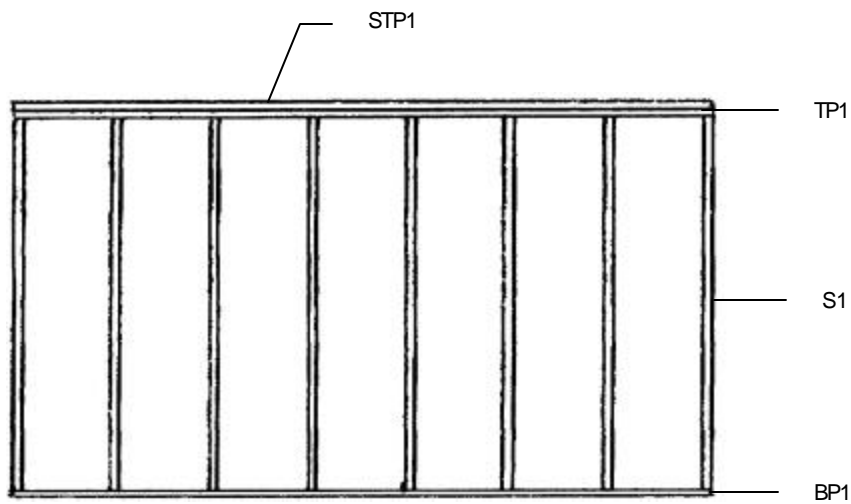

4

WALL BUILDING STEP # 4

THE SECTION OF WALL SHOWN HERE IS WITHOUT SHEETING TO AID IN ILLUSTRATION. FOR THIS SHED PLAN IT IS RECOMMENDED THAT IT BE BUILT AS BUILDING STEP NUMBER 4 OF 4 AND INSTALLED AS INSTALLATION STEP NUMBER 3 OF 4. WITH SHEETING IT WILL WEIGH ABOUT 90 LBS.

**BACK WALL
DETAILS**
SCALE
3/8" = 1'- 0"
SIZE
10'X8'
PLAN
FREE

LUMBER CUTTING INFORMATION FOR ROOF SECTION

DESCRIPTION	SIZE	LENGTH	QUAN	ANGLE	NOTES
RAFTERS	2X4	CUT IN AN AMOUNT AND AS SHOWN ON THE RAFTER CUTTING PAGE			
FRONT & BACK FASCIA	2X5	132"	2		CUT OR TRIM TO FIT AFTER IT IS INSTALLED
SIDE FASCIA	2X5		2	19°/19°	MEASURE AND CUT TO LENGTH
LOOKOUT RAFTERS	2X4	14 1/2"	12		6 FOR EACH SIDE WALL

NOTE! The 90° angle cuts needed are not listed in the angle column. The lengths mentioned here, when there is an angle cut, are always measured at the longest points. When there is a second figure in the angle column, it is for the bottom or the right end that needs to be cut. For more information on cutting lumber see section 4 of our Construction Guide.

5

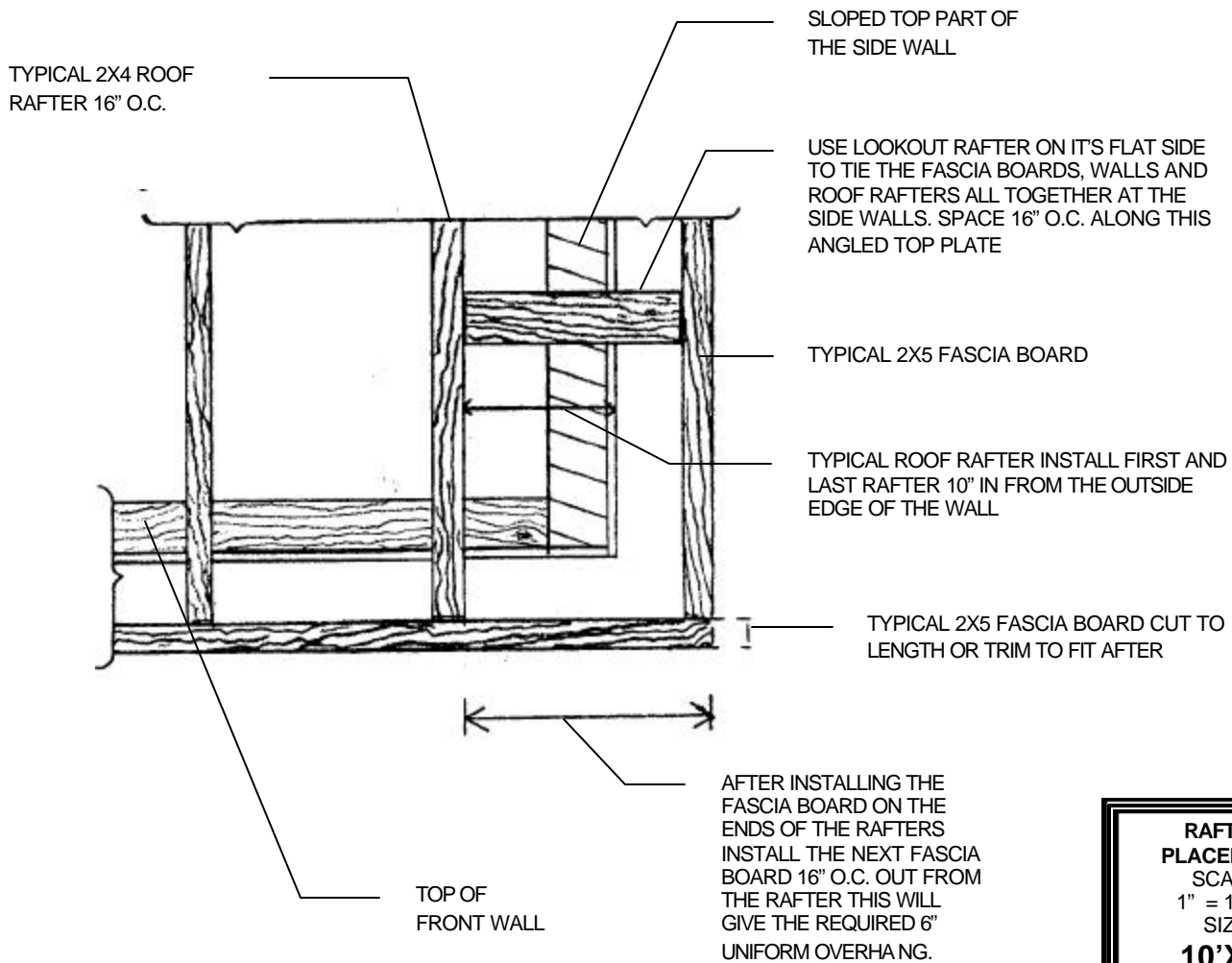

**RAFTER
PLACEMENT
SCALE
1" = 1'-0"
SIZE
10'X8'
PLAN
FREE**

CUT 7 RAFTERS EACH OF THEM 112 1/2 LONG
 THEN CUT THE BIRDS MOUTH AND
 THE 19 ° ANGLES AT EACH END AS SHOWN
 (19 ° IS THE ANGLE USED FOR A 4/12 ROOF PITCH)

TYPICAL 2"X 5"
 FASCIA BOARD FOR
 THE FRONT, BACK
 AND BOTH SIDES

19° ANGLE

TYPICAL 2"X 4"
 SUPPORTING WALL
 WITH 7/16" ASPENITE
 SHEETING

BIRDS MOUTH
 CAREFULLY CUT OUT
 4" FOR THE TOP OF THE
 SUPPORTING WALLS AND
 THEN CUT DOWN FOR THE SIDE

TYPICAL
 4 1/2
 FRONT
 AND
 BACK

NOTE

WHEN CUTTING RAFTERS IT IS BEST
 TO CUT 1 FIRST AND THEN PLACE IT ON
 THE WALLS TO BE SURE IT FITS PROPERLY
 THEN USE IT AS A TEMPLATE TO CUT THE
 REMAINING RAFTERS NEEDED

**RAFTER
 CUTTING
 LAYOUT
 SCALE
 3" = 1'- 0"
 SIZE
 10'X8'
 PLAN
 FREE**

THE START-UP

1. Once you have your plans and know where you are going to place your new shed contact your local public utilities. They will inform you about any pipes or cables that are buried in the ground in the area where you want to build. This is usually a FREE service. It can help avoid costly disruptions in the event that you cause damage to their lines.
2. Know or find out exactly where your property lines are.
3. Contact your local building department and inquire about the required distance needed for side and rear yard set backs if any and about any building permits that you may require.
4. It's a good building practice to take the material list that comes with our plans to your local supplier and review the in stock availability of the materials needed.

FOUNDATIONS

5. If you choose to build your shed using a foundation that is a concrete pier style (rather than a slab-on-grade) then the height of the pier above grade should not be any higher than 3 times the smallest width of the pier.
6. They should also be placed so they will resist any soil or water pressure that acts against them such as that which may take place when building on the side of a steep hill.
7. When building on a concrete pad (slab-on-grade) place anchor bolts no further than 7'-0" apart.
8. All concrete should be at least 1500 P.S.I. in strength. It should be reinforced with wire mesh or re-bar when these plans require or in areas where soil conditions are poor or where earthquakes can occur. Your local building department can advise you on this in your area.
9. Place a moisture barrier (polyethylene plastic sheet; it can be purchased in big rolls or you can use scraps of such plastic if you like) between all concrete and wood or treat that wood with wood preservative.
10. Grade around the shed so that all water drains away from the building to protect it and the contents from water damage.

WOOD FRAMING

11. Where termites are known to exist, wood that they can reach should be treated with a recommended chemical that is toxic to termites.
12. The long nails can be 3 1/2" common or 3 1/4" spiral "Ardox", but must be long enough so that not less than 1/2 their length penetrates into the second member.
13. Nails should be staggered so as to minimize splitting the wood and kept well in from the edges.
14. Use 2" nails to nail all sheeting, spaced 5 7/8" O.C. along the edges of the sheets and 11 1/2" O.C. in-between.
15. Nail structural members as specifically stated on the plans and generally as required in item # 16 of the specifications.
16. Nail framing members using 3 1/4" spiral nails so that not less than 2 nails are used for the ends of each wall stud, ceiling joist, each side and at the end of every lintel. Toe nail rafters to the ridge pole if there is one and to the top of the walls using 3 nails at the end of each rafter. Nail the top 2X4 sill plate and/or the walls to the floor joist at 23" O.C. Nail the double studs at openings and in the corners with nails placed 23" O.C. Use 2 nails wherever the 2X5 fascia boards meet the ends of the rafters. Fill all nail holes with nails in the saddle anchors and joist hangers. The double floor joist and the pieces of built up wood beams shall be nailed together with a double row of nails not more than 18" apart.
17. Use only tongue and groove plywood subflooring or support the edges of the sheets with solid backing underneath.
18. Install all floor and roof sheeting at right angles to the rafters and floor joists.

ATTIC VENTILATION, ROOFING AND SIDING

19. The proper attic ventilation should be obtained by using only vented soffit and the roof vents as called for on the plans.
20. Roofing and siding should be installed in strict accordance with the manufacturer's instructions, including the recommended starter strips and all recommended trim.

WINDOWS AND DOORS

21. Using windows and doors other than those called for will not affect the building provided they are the same size, function in the same way and they should have the same appearance and be of equal quality.
22. Quality caulking should be applied around all openings so as to prevent water from coming into your new shed.

OPTIONS

23. Owners choosing to add options to their sheds such as heating, plumbing and an electrical service should consult area trades people regarding their needs.

GENERAL

24. In spite of these plans, specifications and or advice and construction guides provided by Just Sheds Inc. it becomes by building, the owner's sole responsibility to apply for all required permits, to build so that it is in accordance with all required skill, standards and in a safe and skillful manner that suits the intended purpose in that area.

Please Always work safely



No.	QUAN	SIZE	DESCRIPTION AND USE	NOTES
1	2	6" X 6" X 10'	Cedar or pressure treated wood (USE ONLY FOR SKID FOUNDATION)	1,2,3
2	8	2"X 6"X 16'	Solid bridging, floor and header joists (USE ONLY FOR SKID FOUNDATION)	1,2,7,3
3	4	3"X 3"	Steel saddle anchors (or 10 anchor bolts if concrete pad is used)	
4	6	2"X 8"X 10'	3-pc built up beam at the front and back	1,2,7,3
5	11	2"X 8"X 8'	Single and double floor joist as shown on the plans	2,7,3
6	14	2"X 8"	Single joist hangers (install before plywood)	7
7	3	4'X 8' X 5/8"	Tongue and groove plywood	7
8	9	2"X 4"X 16'	When cut will give 1 bottom and 2 top plates for all walls plus misc. needs	1,3
9	20	2"X 4"X 14'	When cut will give the needed studs of various lengths	1,3,5
10	9	4'X 8'X 7/16"	Aspenite wall sheeting	
11	4	2"X 5"X 12'	Fascia boards all around	3,4
12	9	2"X 4"X 10'	Roof rafters	
13	4	4'X 8'X 3/8"	Spruce plywood roof sheeting	
14	24	3/8"	H clips or use scrap wood to support roof sheeting edges	
15	110	Sq. ft.	Asphalt roof shingles (includes starter strip)	
16	11	Linear ft.	Metal cap flashing	
17	1		Andersen window "NARROLINE" # 2046	6
18	1		Therma-tru door # CS210 (outswing is another option)	6
19	1		Locking door knob (check with door supplier regarding size, set back etc.)	
20	12	4'X 8'X 7/16"	Aspenite sheeting for interior walls and ceiling	
21	12 lbs	3 1/4"	Ardox or spiral framing nails	5
22	12 lbs	2"	Ardox or spiral framing nails	5
23	9 lbs	1 1/4"	Roofing nails; use for shingles, asphalt paper, vinyl siding and trim	5
24	300	Sq. ft.	# 15 asphalt paper	
25	36	Linear ft.	Vinyl siding starter strip	
26	4	3/4" X 3"X 10'	Vinyl siding outside corner post	
27	30	Linear ft.	J channel	
28	40	Linear ft.	F channel (wall mounted to hold soffit material)	
29	22	Sq. ft.	Vented soffit	
30	44	Linear ft.	Under sill trim; use under window and on the top edge of the vinyl fascia	
31	44	Linear ft.	6" vinyl fascia	
32	6	Linear ft.	Vinyl door and window cap	
33	270	Sq. ft.	Double 4" vinyl siding	
34			Misc. caulking and paint for the door	

Pride will result when adding labor to the above.

NOTE: PLEASE READ ALL NOTES AND SPECIFICATIONS BEFORE ORDERING ANY MATERIALS OR BUILDING

- 1 When cut in two or to the required size one piece will yield the needed amount.
- 2 Cedar or pressure treated wood is recommended. Use cut end treatment if treated wood is used.
- 3 Grade numbers 1 and 2 spruce is the specified lumber for this project.
- 4 2"X 5" lumber is recommended because it suits the 6" vinyl fascia best.
- 5 Consider ordering a few more of these items or others as it is common to use more because of working style, waste or mistakes.
- 6 Always confirm the size of the unit and the rough stud opening (R.S.O.) from the supplier before ordering or building.
- 7 Delete these items and 18 sq. ft. from no. 33 if you choose to build your shed on a concrete pad.
- 8 Not knowing your site or soil conditions prevents us from estimating any of your concrete needs.
- 9 It is the owner's responsibility to apply for all required permits and to build with the necessary skill and in accordance with all required standards.



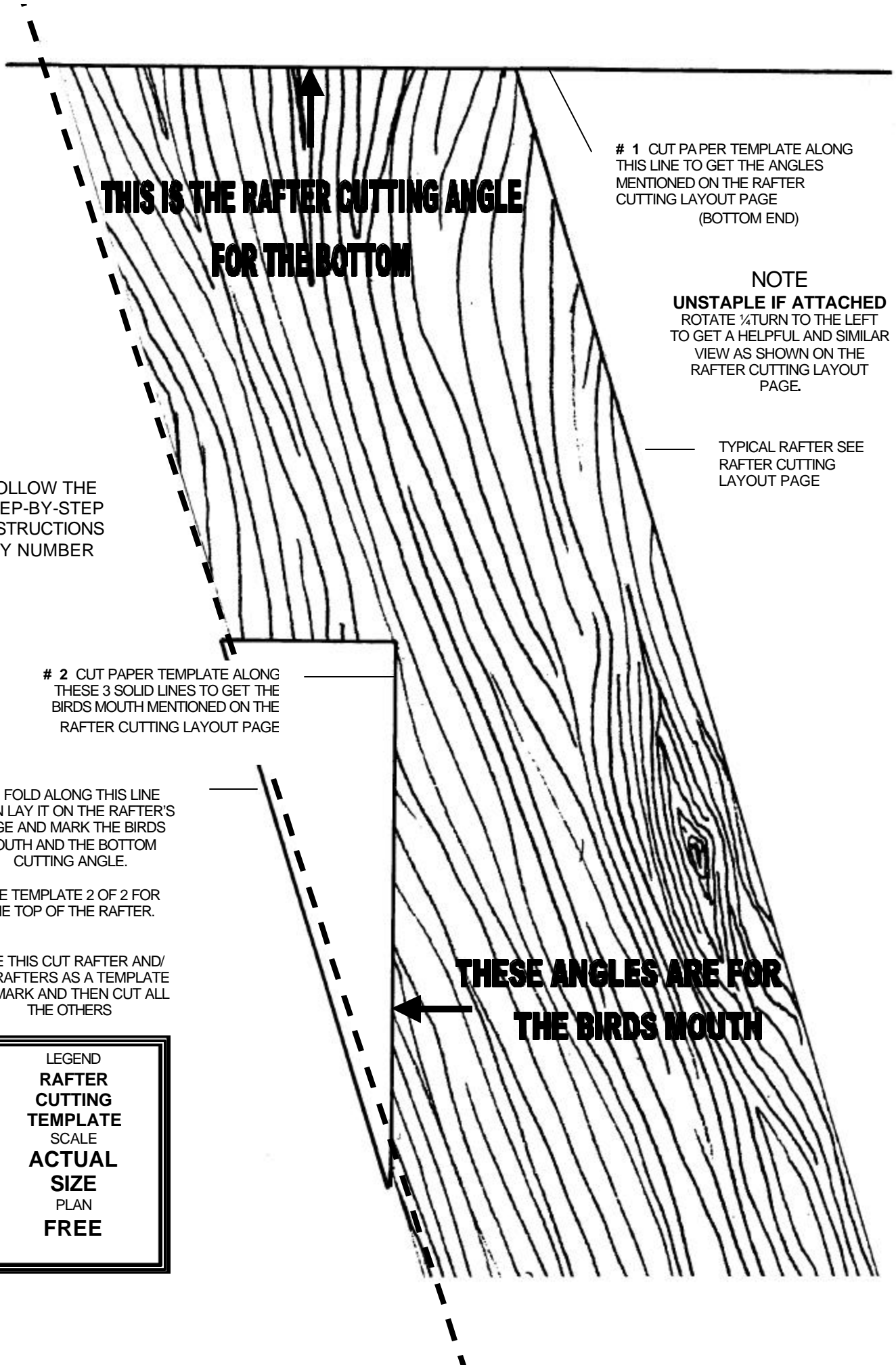

1 CUT PAPER TEMPLATE ALONG THIS LINE TO GET THE ANGLES MENTIONED ON THE RAFTER CUTTING LAYOUT PAGE (BOTTOM END)

NOTE
UNSTABLE IF ATTACHED
ROTATE ¼TURN TO THE LEFT TO GET A HELPFUL AND SIMILAR VIEW AS SHOWN ON THE RAFTER CUTTING LAYOUT PAGE.

TYPICAL RAFTER SEE RAFTER CUTTING LAYOUT PAGE

FOLLOW THE STEP-BY-STEP INSTRUCTIONS BY NUMBER

2 CUT PAPER TEMPLATE ALONG THESE 3 SOLID LINES TO GET THE BIRDS MOUTH MENTIONED ON THE RAFTER CUTTING LAYOUT PAGE

3 FOLD ALONG THIS LINE THEN LAY IT ON THE RAFTER'S EDGE AND MARK THE BIRDS MOUTH AND THE BOTTOM CUTTING ANGLE.

USE TEMPLATE 2 OF 2 FOR THE TOP OF THE RAFTER.

USE THIS CUT RAFTER AND/OR RAFTERS AS A TEMPLATE TO MARK AND THEN CUT ALL THE OTHERS

LEGEND
RAFTER CUTTING TEMPLATE
SCALE
ACTUAL SIZE
PLAN
FREE

**THIS IS THE RAFTER CUTTING ANGLE
FOR THE TOP**

1 CUT PAPER TEMPLATE ALONG THIS LINE TO GET THE ANGLES MENTIONED ON THE RAFTER CUTTING LAYOUT PAGE (TOP END)

NOTE
UNSTAPLE IF ATTACHED
ROTATE 1/4 TURN TO THE RIGHT TO GET A HELPFUL AND SIMILAR VIEW AS SHOWN ON THE RAFTER CUTTING LAYOUT PAGE.

TYPICAL RAFTER SEE RAFTER CUTTING LAYOUT PAGE

**THESE ANGLES ARE FOR
THE BIRDS MOUTH**

FOLLOW THE STEP-BY-STEP INSTRUCTIONS BY NUMBER

3 FOLD ALONG THIS LINE THEN LAY IT ON THE RAFTER'S EDGE AND MARK THE BIRDS MOUTH AND THE TOP CUTTING ANGLE AT THE LENGTH MENTIONED ON THE RAFTER CUTTING LAYOUT PAGE USE TEMPLATE 1 OF 2 FOR THE BOTTOM OF THE RAFTER.

USE THIS CUT RAFTER AND/OR RAFTERS AS A TEMPLATE TO MARK AND THEN CUT ALL THE OTHERS

2 CUT PAPER TEMPLATE ALONG THESE 3 SOLID LINES TO GET THE BIRDS MOUTH MENTIONED ON THE RAFTER CUTTING LAYOUT PAGE

LEGEND
RAFTER
CUTTING
TEMPLATE
SCALE
ACTUAL
SIZE
PLAN
FREE