

52

CHILDREN'S BUNKHOUSE LOFT



Children's bedrooms are frequently the smallest rooms in the house. And, as the youngsters grow, their space seems to become smaller. One way to lessen this problem is to go vertical, as in building a loft.

The loft we've constructed was made from 12 simple 2x6s in 8'

lengths. We used standard yellow pine, but did spend a few minutes at the lumberyard trying to pick out the best looking wood without large knots, twists or terribly mangled edges.

Even having been picky with our lumber, we still felt more comfortable ripping and planing the boards

to 1 1/2" x 5" to remove the factory edges and to make sure the material was uniform.

Once your boards are ready, pick the straightest ones and cut the five long rails to length. Work through the cutting list from longest to shortest, getting your shortest lengths from the worst lumber.

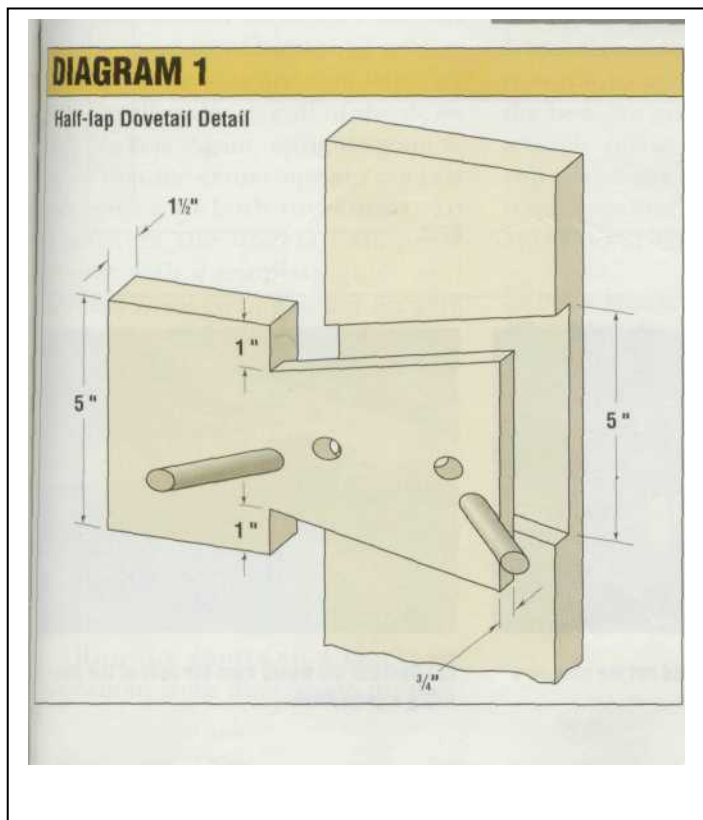

### Loft Frame Cutting list

	No.	Size
Posts	5	1 1/2" x 5" x 60"
Face frame rails	4	1 1/2" x 5" x 82 1/4"
Face frame rail	1	1 1/2" x 5" x 61 1/2"
End rails	4	1 1/2" x 5" x 41"
Step rails	4	1 1/2" x 5" x 26"
Mattress support	1	3/4" x 40 3/4" x 75 1/2"

### Bookcase Cutting list

	No.	Size
Shelves	6	3/4" x 8" x 39 1/2"
Ends	4	3/4" x 8" x 30"
Backs	4	3/4" x 6" x 39 1/2"
Shelf supports	12	3/4" x 1 1/4" x 39 1/2"
Cleats	12	3/4" x 1 1/4" x 4 1/2"

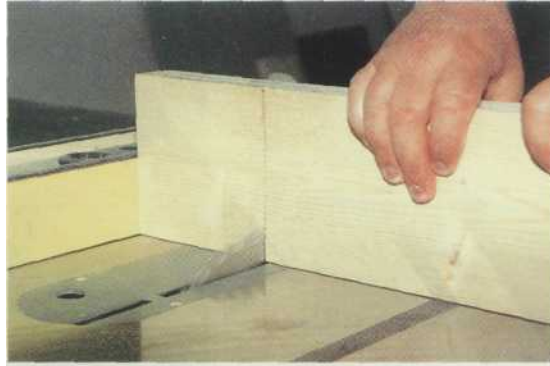

**1** The shoulder of the pin is cut on the table saw, 5" in and 1"

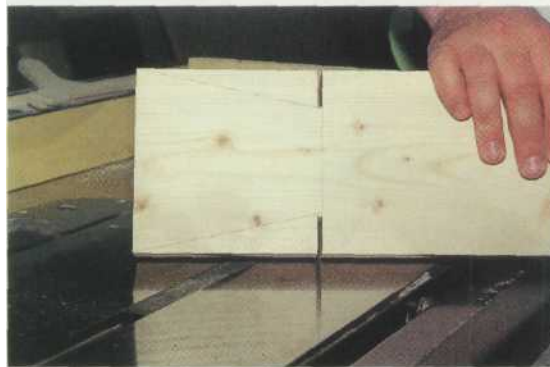

**2** Flip the board and make the same cut on the opposite side. Note the angle for the dovetail.

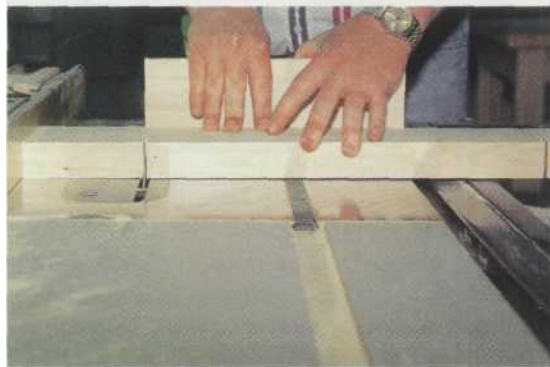

**3** Lower the blade to 3/4" and run the backside of the pins to form the joint's cheek.

You're now ready to cut the half-lap dovetails which will provide aesthetics, as well as stability and strength, to the loft (diagram 1). Start by separating the lumber into vertical (posts) and horizontal (rails) piles. All of the horizontal pieces (the five longer rails and the steps) will receive the pins for the dovetails.

The first cut, to form the shoulder of the pin, was accomplished on the table saw using the rip fence as a guide set at  $4 \frac{7}{8}$ " (5" with the kerf) (photo 1). We chose to work with a  $12^\circ$  angle for the dovetails, and marked the board to use the entire width. Photo 2 shows the defined shoulder and the pin as marked.

Without changing the rip fence setting, lower the blade height to  $\frac{3}{4}$ ". Then run the back side of each pin to form the cheek of the joint (photo 3). Take note, we had all the dovetails' joints visible to the front of the bed, including those on the rear frame.

To form the pin itself, move to the

## DIAGRAMS 2 & 3

Diagram 2 Front Frame Layout

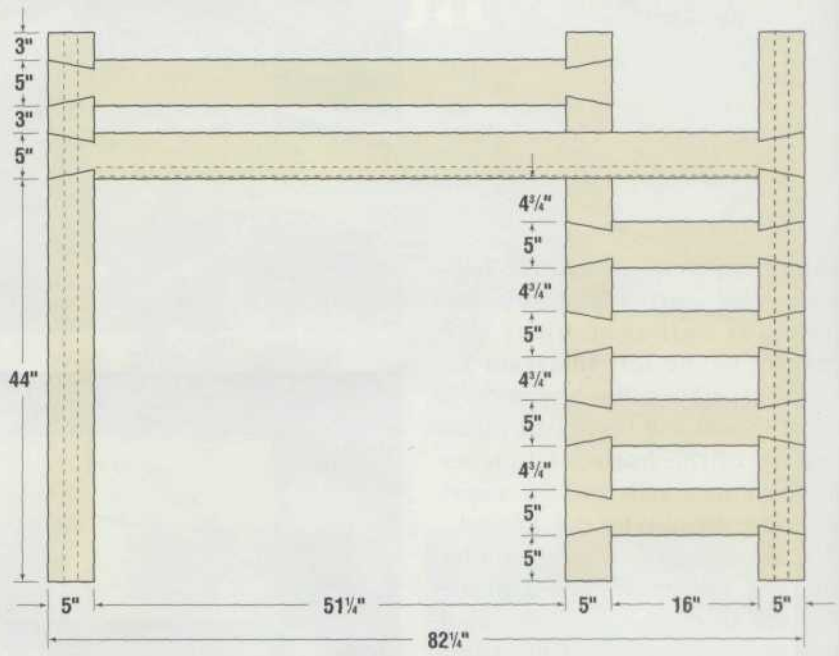

band saw and follow your 12° marks, cutting from the front side (photo 4). We freehanded the cuts since the overall finish of the piece is intended to be rustic. If you choose, a sled jig can be made to cut the tails in a more exact manner.

The final step in forming the pin is to remove the waste from the rear to form the half-lap. After considering a number of methods of per-

Diagram 3 End and Rear Frame Layout

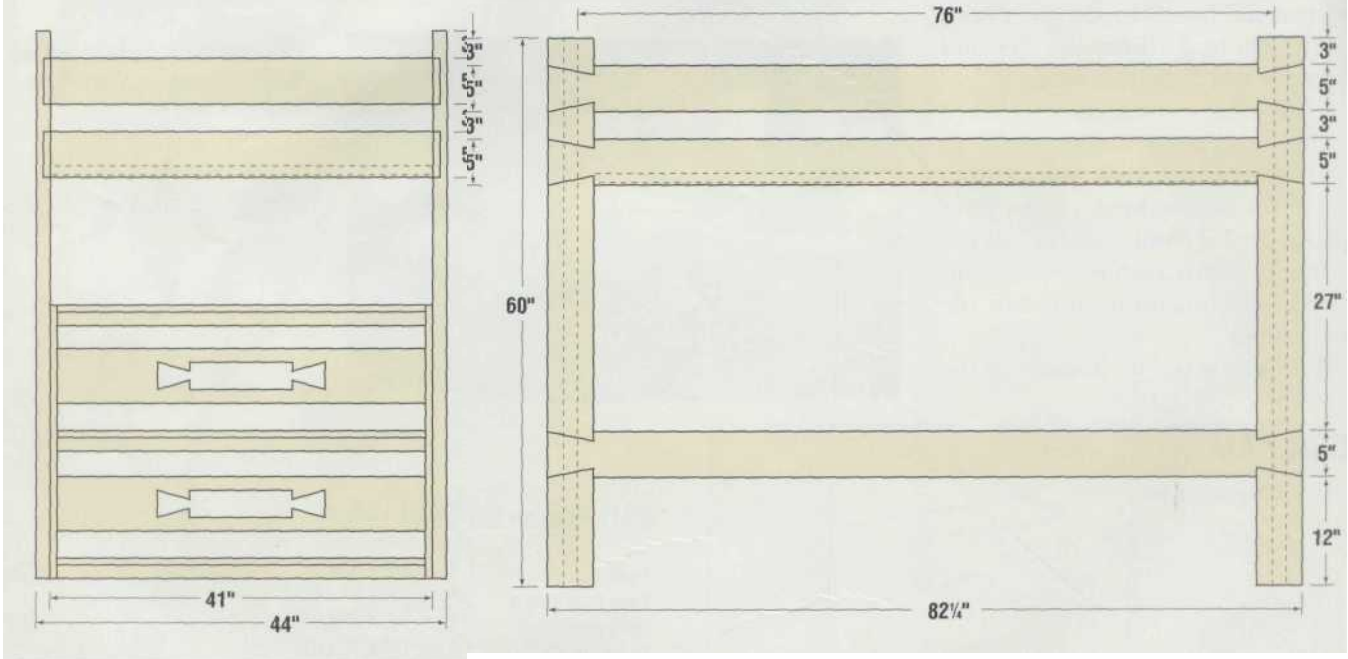

forming this step (hand sawn, resawn on the band saw, using a router), we opted to use a dado stack on the table saw (photo 5). This method removed the waste quickly, and in a safe and uniform manner. If the dado stack isn't an option for you, the router may be your next best choice.

To form the dovetail pockets, we marked the location of all the pock-

**4** Follow the 12° marks and cut the pins on a band saw.

**5** Remove the waste from the rear of the pin using a dado stack.





6 Remove the waste from the dovetail pockets using the dado set-up.



7 Detail showing dovetail pockets and the full 5" half-lap.

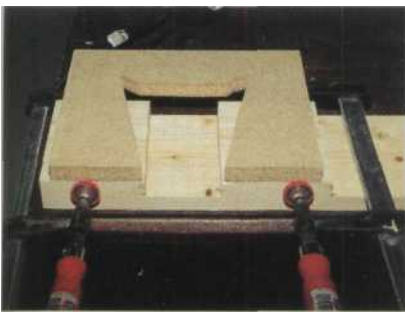

8 A template guide makes quick work of finishing the dovetail shape



9 1 1/2" dowels, cut on the band saw, help make the joint stronger.

To make the joint even stronger (and the whole piece more aesthetic), we used 1/2" dowels to pin the dovetail joints. Cut the dowels to uniform length (1 1/2") using the band saw. To make the cut safely we used a piece of tape to mark the length (photo 9). Don't work too fast and

ets (diagrams 2 & 3), left the dado stack in the saw and removed most of the material from the posts (photo 6).

As you're cutting the dadoes, note that the center post requires a full 5" half-lap joint (photo 7). The mate to this joint should be located and cut on the lower front horizontal rail.

After these cuts are complete, lay out the direction for all of the dovetail pockets. Again, using diagram 2, note that the center upright pockets are going in both directions. To complete the dovetail shape, a router with a template guide and upward spiral cutting router bit were used. The template can be made out of most any common scraps in your shop (photo 8).

Clamp the template firmly in place. If you're using a 1/2" shank bit, the router depth can be set to match the full dado depth and cut in one pass. If you're using a 1/4" shank, you'll want to use two depth passes to remove the waste material.

Run the router in the direction, from

ing at the bottom left. Be careful not to run the router in the opposite direction, as it may cause kickback.

Once all the pockets are cut, check the fit at each joint. Chances are good some minor adjustments with a chisel will be required.

In gluing-up the front and back frames you may want to consider how transportable you want to make the bed. We glued each frame up as a single piece, but for convenience you may want to screw parts of the frame together to make it more of a knock-down design.

keep your fingers clear.

Start your glue-up with either the right or left end of the back frame. Use a flat work surface which you can clamp the glued components to. Cover all touching surfaces of the joint with glue and clamp the two pieces together.

Next mark a 1/2" drill bit at 1 1/4" with a piece of tape. Then, with the drill held at an approximate 45° angle, drill two holes through the dovetail joint, stopping at the tape (photo 10). The two holes should be drilled at opposing angles. The

10 Drill 1/2" holes at a 45°, 1 1/4" deep, to accept the dowels.



dowels



11 The dowels in place and the joint clamped.



12 After the glue has dried, cut the dowels with a hand saw.



13 The knock-down hardware installed.



14 The aluminum "L" track is mounted 1" up from the bottom edge of the rail

15 Veneer tape is simply ironed on to the visible edges of the MDF board.



should be glued and hammered into place (**photo 11**). We used a smaller dowel to spread the glue around the interior of each hole to get even coverage. Repeat this process for the other two joints on that end and let dry.

After the glue has set, repeat the process on the opposite end. Then move to the stair section, and finally the left end of the front frame.

After both frames have dried, any dowels extending beyond the frame

can be cut flush with a hand saw (**photo 12**).

Unless you've been extraordinarily precise or lucky, your joints will more than likely not fit flush in all places. If you try to sand or plane these joints flush, you'll end up doing more harm to the appearance than good. So, in keeping with the overall rustic look, we opted to leave any rough joints as they were.

To make the loft more "child friendly," we used a 1/4" roundover bit

in a router on all the edges of both frames and the long edges of the four end rails.

The next step is to install the knock-down hardware to assemble the bed. Many types of

knock-down hardware are on the market, so the type you choose may be quite different from ours. With our hardware it was necessary to rout pockets in both the face of the frames and ends of the cross pieces that mount the KD plates flush to the surface (**photo 13**).

Assemble the bed to check the fit of all pieces.

This also is a good opportunity to measure and attach support rails for the 3/4" plywood which will, in turn, support the mattress. For our loft we chose a 1/8" gauge aluminum "L" track drilled, countersunk and mounted 1" up from the bottom edge of the lower rail (**photo 14**).

This is not, however, the least expensive method to support the plywood and mattress. Other fine alternatives include 1" x 1" wood strips attached in the same location, or "L" brackets rather than "L" strips. Regardless of your choice of material, make sure it will support plenty of weight without allowing the plywood to slip out of place.

At this point the loft is essentially complete; but to provide toy and book storage and to strengthen the overall piece, we added a couple of simple bookcases (**diagram 4**).

The cases were made from 3/4" MDF (medium density fiberboard) material with a factory Birch veneer on both sides. To finish the look of the pieces we used Birch veneer tape on the visible MDF edges. The veneer tape is simply ironed on (**photo 15**),

**16** Once the veneer has been attached, it can be trimmed using a block plane.

then trimmed to fit using a block plane (**photo 16**) and sanded flush.

Part of the Southwestern detail is achieved by using a jigsaw to cut out part of the backs (**diagram 4 & photo 17**).

The next step is to attach the pre-drilled shelf supports and cleats to each shelf's underside (**diagram 5**).

After that, it's a simple process of screwing the cases together. The backs were pilot drilled and screwed into place through the case ends. When in place between the posts of the bed, these screws won't be visible. The cases themselves are then screwed between the posts from the inside.

As shown in the opening photograph, we used an oil-based grey

wash stain which was a simple wipe-on, wipe-off process. This brought out more of the wood's character and gave the piece a more antiqued "barn board" look. We used multiple coats of lacquer with a dull finish to seal and protect.

You've no doubt by this time realized that these same plans can be rearranged to fit your particular space needs. In fact, you can even duplicate the frame's upper structure and make a traditional bunk bed. However you design it, we hope your special youngsters enjoy their time "aloft."

## DIAGRAMS 4 & 5

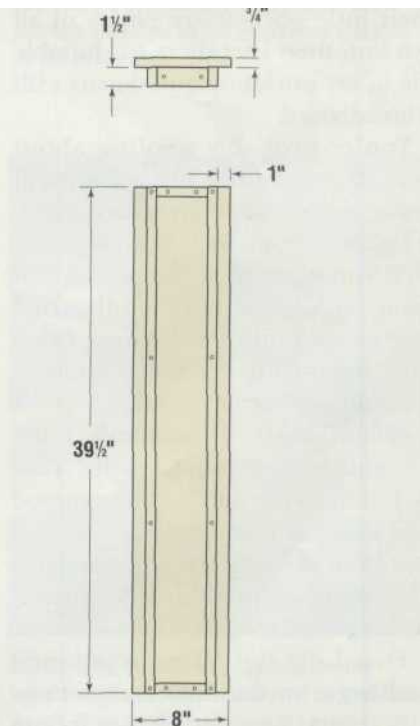
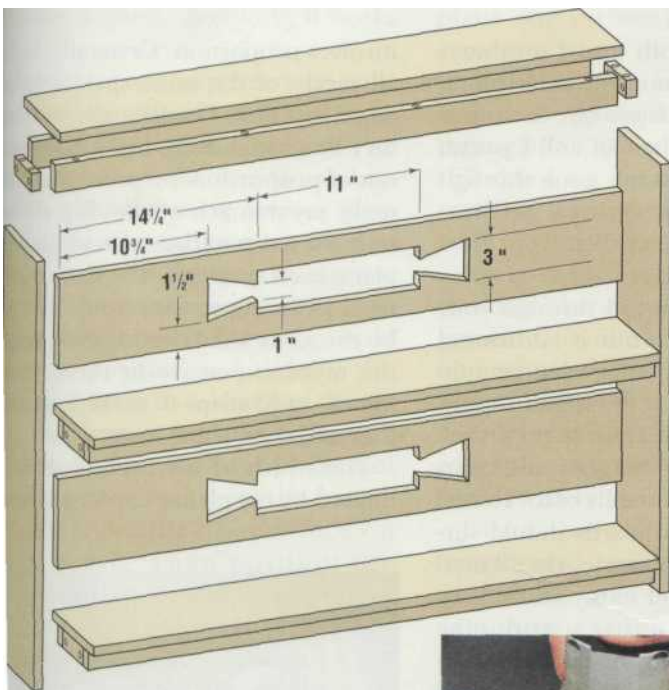

**17** The Southwestern detail is created with a jigsaw.