

# HOW-TO BOOKLET #3056

## DOOR LOCKSETS



### TOOL & MATERIAL CHECKLIST

- Hand Brace
- Auger Bit
- Screwdriver
- Butt Chisel
- Tape Measure
- Square
- Lockset (Tubular or Cylindrical)
- Hole Saw or Electric Power Drill with Expansive Bit
- Utility Knife and Blades

*Read This Entire How-To Booklet for Specific Tools and Materials Not Noted in The Basics Listed Above.*

Lockset designs are almost limitless. There are metals in chrome, brass, glass, pottery, aluminum. There are tubular and cylindrical locks and rim locks and deadlocks for safety and protection. In fact, deciding on what style lock you want may be more difficult than installing the lock after you buy it.

**THE BIG TWO.** “Standard” locksets found in almost all home center, building material, and hardware stores are tubular locks and cylindrical locks. In design, both look about the same. In function, the locks are different:

**Tubular locks** are manufactured for interior doors, sometimes called “passage” or “pass” doors. Only two holes are needed to mount tubular locks in doors: one hole for the knob assembly and another hole for the latch bolt assembly. There are design options: some locksets have a pushbutton in the knob for lockout—such as for bathroom doors. The lock is on the inside of the door; if a child locks the door and can’t get out, you can activate the lock by sticking a nail or stiff piece of wire into a small hole in the knob of the lockset on the outside of the door. Similar locksets do not have a locking device—just a latch system that keeps the door latched in a shut position. You turn the knobs to move the latch.

Tubular locks are usually less expensive than other types of residential locks. And, these locks are usually packaged with installation instructions and a templet for cutting holes in the door.

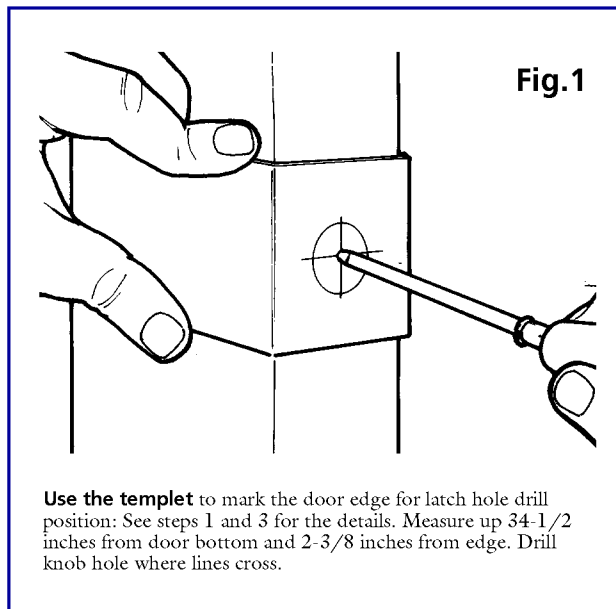

Fig.1

Use the templet to mark the door edge for latch hole drill position: See steps 1 and 3 for the details. Measure up 34-1/2 inches from door bottom and 2-3/8 inches from edge. Drill knob hole where lines cross.

**Cylindrical locks** are made for exterior or entrance doors, and, therefore, they are heavier and stronger than tubular locks. The outside knob of this lockset is keyed; the inside knob has a pushbutton device so the door may be locked from the inside by pushing a button, or the entire knob, toward the door. For security reasons, the lockset is mounted from the inside of the door so no screws are available for disassembling the lockset.

#### Other Options:

**Deadlocks** or deadbolts are a 2-hole locking assembly. Outside, the lock is operated by a key. Inside, the lock is turned by a thumb lever. Or, the inside is also key-operated. If there is glass in the door, a key-operated deadlock is the best buy: an intruder would need a key to unlock the door even if the glass was broken.

**Rimlocks** could be termed security locks more than passage locksets since they have a spring latch that automatically locks the door when the door is closed. Other rimlock designs are key-operated. Rimlocks are better than cylindrical locks for security. However, deadlocks are better than both from a security standpoint. Rimlocks are easy to install, however. The lock case and strike plate are simply screwed to the inside of the door and door casing.

### LOCKSET INSTALLATION

Installing a lockset, or replacing one, is a very easy do-it-yourself project. Little skill is necessary, but patience is needed to make sure all measurements and holes are accurate. Below, and in the illustrations, are the steps involved in installation:

**1** Most locksets are packaged with a paper or light cardboard templet which positions the holes in the surface and edge of the door.

Measure and mark a line from 34-1/2 to 36 inches from the bottom back of the door and from 2-3/8 to 3 inches from the edge toward the hinges. The distance from the edge will vary by lockset type; standards in this booklet will be 34-1/2 and 2-3/8 inches. Use a square

**Fig. 2**

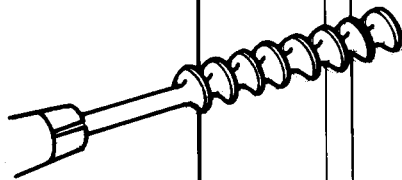

Use an auger bit to drill latch hole; hole saw or expansive bit for knob hole. Keep the bit square to the edge of the door until the hole inner-connects with the knob hole. Test latch bolt in hole.

**Fig. 4**

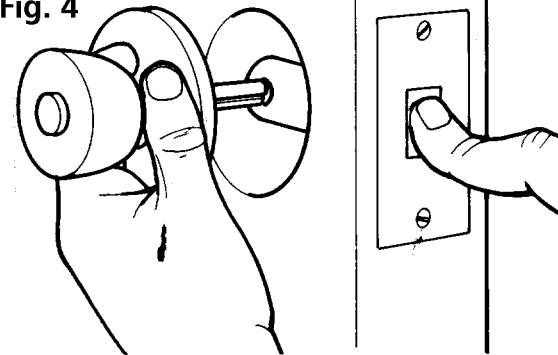

Install interior knob into exterior knob and fasten both together as a unit with screws from the interior. Hold down latch so knobs mate; latch plate is fastened at this time.

**Fig. 3**

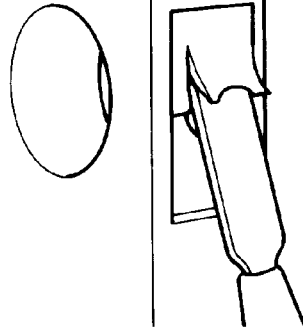

Trace outline of latch plate on door edge while latch bolt is in position. Then mortise out wood to countersink the latch plate flush with surface of the door edge. Use butt chisel for cuts.

**Fig. 5**

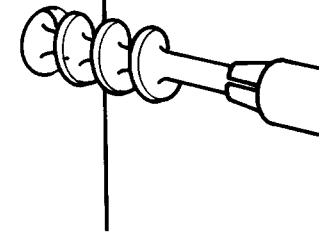

Measure, mark, and drill for strike plate on door jamb. Lockset should provide a paper templet for this. Go into wood about 1/2 inch, keeping the bit square with the door jamb.

and mark an X where the lines meet. The center of the X is center of the hole. Mark the templet accordingly (**Fig. 1**).

Once in position with the marks, the templet now will locate the latch hole position in the edge to the door. Mark the edge of the door at this spot with a nail point (or a bradawl if you have one or an icepick); the mark from the nail will indicate where the point on an auger bit should be set to drill the latch hole. Both knob

and latch holes should now be marked on the door. Just to be sure, double-check the measurement from the bottom and edge of the door. Use the templet, too.

**2** The hole through the surface of the door can be drilled with either a hole saw or an expansive bit. The expansive bit is a type of auger bit that is expandable to width. It is used in a hand brace. Of the two, the hole saw costs less, if you already own a portable electric drill. The

Fig. 6

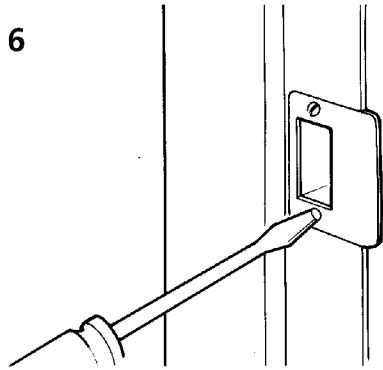

**Mortise** for the strike plate, then screw the plate into position. Test the lock. If strike plate doesn't meet latch properly, you can adjust it in the mortise or shim out the hinges with thin strips of cardboard.

hole saw has an arbor and pilot bit to start the saw in the wood. The size of the hole for most locksets is 2-1/8 inches. However, double-check the label on the lockset package; the hole needed may be a tad larger or smaller than the 2-1/8 inch size.

Keep the drill square with the surface of the door. When the point of the bit or pilot bit comes through the door on the opposite side, stop drilling. Remove the saw a bit and finish drilling from the other side, using the drill point break-through as a position guide. By reversing the drilling operation, you will prevent splitting the wood when the saw/drill completes the hole.

- 3** When the hole in the surface is complete, drill the hole in the edge of the door for the latch bolt. You will need a 15/16-inch auger bit for the latch bolt hole, unless otherwise specified in or on the lockset package. Position the screw-tip on the bit in the hole you punched in the wood. Keep the bit perfectly square with the edge of the door until the bit breaks through the hole you drilled through the surface of the door. You now have an "inner-connected" hole: one for the knob and one for the latch bolt (**Fig. 2**).

- 4** The latch plate is part of the latch bolt. Insert the latch bolt into the edge of the door and press it tight against the edge so it is square. Then with the tip of a utility knife blade or pocketknife, outline the rectangular shape of the latch plate in the wood on the door's edge. Remove the latch bolt.

With a butt chisel, cut the mortise for the latch plate. Make a series of shallow chisel cuts across the cutting lines, but keeping the cuts inside the lines. Then, with the bevel of the chisel up, chip out the cuts. Easy does it; don't split the wood (**Fig. 3**).

After the first cut is made, try the latch plate in the mortise. Note where it is "high," and then very carefully remove the high spot with the chisel. When you are finished, the latch plate should fit flush in the mortise, i.e., the top surface of the plate should be level with the edge of the door surface.

If too much wood is removed, you can shim out the latch plate with a layer or two of cardboard. However, by working slowly and testing the latch plate in the mortise often, the fit should be perfect.

- 5** Leave the latch bolt in the hole and fasten it to the edge of the door—in the mortise—with the screws provided. You can punch pilot holes for the screws in the wood with a nail point. Turn the screws clockwise until they are tight. Do not overtighten or you'll strip the wood with screw threads. Most screws are Phillips' slotted.
- 6** Push the latch bolt flush to the latch plate with a thumb, and insert the exterior knob assembly into the knob hole and through the hole in the latch bolt assembly. The positioning should be an easy slip-fit; don't force the knob assembly. Once in place, remove your thumb from the bolt (**Fig. 4**).
- 7** Mate the interior knob with the exterior knob stem, after you insert the decorative rose or escutcheon between the knob and the door

surface. Position the rose or escutcheon screw-holes where you want them, punch pilot holes for the screws with a nail point, and drive the screws, clockwise. Test the knobs, latch and lock. All should work perfectly. If not, remove the interior knob and inspect the stem from the exterior knob as it goes through the latch bolt assembly. It could be misaligned.

- 8** Locate the strike plate on the door jamb (opposite the latch bolt). The package should have a templet for this. If not, measure the distance from the front edge of the door to the flat of the latch bolt, which will face the interior of the house. Transfer this measurement on the jamb of the door, using the doorstop as the starting-point. Shut the door. Measure up the door 34-1/2 inches from the bottom edge and mark this on the door jamb. Hold the strike plate at this mark on the jamb and with a pencil mark the inside of the strike plate hole and the outside of the strike plate on the jamb. Double check the measurements. The fit should be perfect.
- 9** X the center of the strike plate outline. Where the lines cross is the drilling point. Drill a 1-5/16-inch hole at the X. The hole should be about 1/2-inch deep to accept the latch bolt (**Fig. 5**). Close the door and check the fit. With a butt chisel, cut a mortise using the outline of the strike plate as a guide. The depth of the mortise should be the thickness of the strike plate. See Step 4 for details. Attach the strike plate with the screws provided. They turn clockwise. When you are finished, the strike plate should fit flush with the door jamb (**Fig. 6**).
- Close the door and check the door's fit against the door stop and the inside casing. The door should be flush against the stop and casing. It may be gapped at either. If the misalignment is really not noticeable unless you eyeball the surface up close, let it go. If the misalignment is noticeable at the door stop, you can remove and reposition the stop, using the surface of the door as a guideline. If the misalignment

is against the inside casing, you will have to adjust the hinges one way or the other to bring the door back square in the opening so it aligns with the casing. Sometimes a cardboard shim in back of a hinge leaf will bring the door into alignment. Try this before remounting the hinges.

## INSTALLING A DEADLOCK

Deadlocks, or deadbolts, are installed almost the same way as locksets. Two holes are required in the door—one for the cylinder and one for the bolt.

Position of the deadlock can be about 12 inches above the lockset (typical) or about 6 inches below it. This spacing provides a “double” lock effect—one from the lockset and one from the deadlock. However, no instructions have been cast in concrete that say the deadlock has to be in this position. It could be at the top or bottom of the door. The problem here may be inserting the key. Or, you could install two deadlocks—one above and one below the regular lockset.

- 1** Measure, mark, and position the templet for the deadlock on the door. Then X the spot where the point of the auger bit is positioned. If no templet is furnished, measure up or down about 12 inches from the lockset. Mark this point.
- 2** With an auger bit, drill the hole for the cylinder through the surface of the door. Then, mark with a nail point the position for the bolt and drill this hole from the edge of the door to the hole for the cylinder. The size bit you need can vary. Check the size on or in the deadlock package.
- 3** Install the bolt in the hole in the edge of the door and mark an outline of the plate on the door edge. Remove the bolt. With a chisel, cut a mortise for the plate. The depth of cut should be the thickness of the plate.

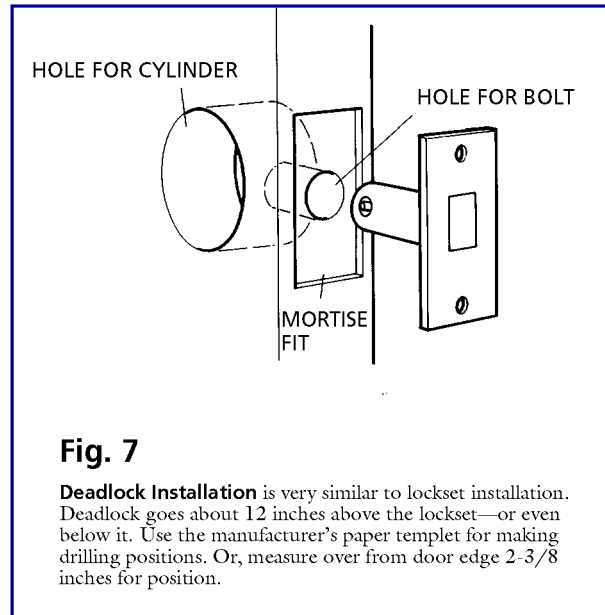

**Fig. 7**

**Deadlock Installation** is very similar to lockset installation. Deadlock goes about 12 inches above the lockset—or even below it. Use the manufacturer’s paper templet for making drilling positions. Or, measure over from door edge 2-3/8 inches for position.

- 4** Insert the bolt in the hole and fasten it to the door with the screws provided (**Fig. 7**).
- 5** Insert the cylinder, working from the keyed part (exterior) to the thumbscrew (interior). Screw the parts together from the interior. Test the lock with the key and/or thumbscrew (**Fig. 8**).
- 6** Locate the strike plate as detailed above for a regular lockset. Some deadlocks have a double strike plate. That is, the flush-mounted plate is backed up with a reinforcing plate. If your lock has this feature, drill the hole for the bolt and mortise for the flush-mounted plate. Install the reinforcing plate first, using 3 inch screws driven into the jack stud. Then screw on the flush mounted plate. If the bolt has to be extended to go into the deeper bolt hole, adjust the cylinder and thumbscrew along the bolt where the cylinder assembly

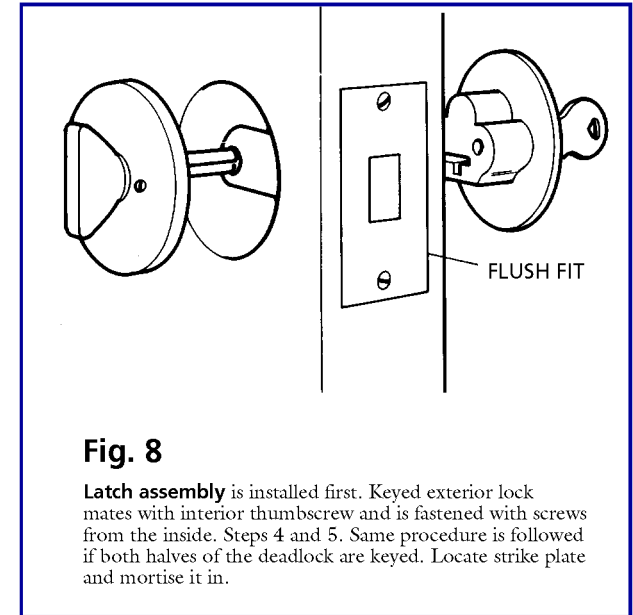

**Fig. 8**

**Latch assembly** is installed first. Keyed exterior lock mates with interior thumbscrew and is fastened with screws from the inside. Steps 4 and 5. Same procedure is followed if both halves of the deadlock are keyed. Locate strike plate and mortise it in.

goes through. There should be an extra hole or slot for this.

## MASTER KEYING DATA

If you are installing new exterior locksets at your house, you may want to have the locks “master-keyed” so one key fits all locks. Some retailers that sell locksets have the equipment to master key. There may be a charge for this.

To master key a lock, one lock must be chosen. The other similar locks are then disassembled and re-pinned to match the prime lock. Depending on the lock manufacturer, master-keying can take an hour or several hours to do.