

# Project 16301EZ: Colonial Sign

*A handsome sign always seems to add a little charm to the family homestead. As shown, our sign is compact enough to mount just about anywhere. Hanging from a post by the driveway entrance or mounted on the porch near the front door, it will proudly proclaim who dwells within. With the 1-1/2" high letters (I) shown you should also have room for the house number. Many hardware stores now carry wood letter and number packages, so you should be able to find them locally.*

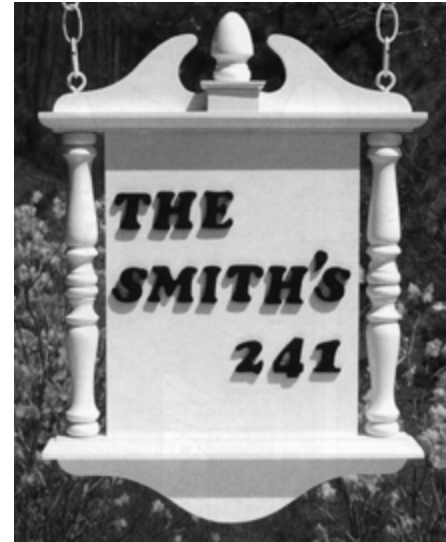

## Colonial Sign Materials List

Part	Description	Size	No. Req'd
A	Top/Base	3/4" x 2-1/4" x 14"	2
B	Bottom	3/4" x 2-5/8" x 14"	1
C	Crest	3/4" x 3" x 14"	1
D	Block	3/4" x 3/4" x 2"	2
E	Cap	3/8" x 2-3/4" x 2"	2
F	Signboard	1/2" x 10" x 12-1/2"	1
G	Finial	As shown.	1
H	Column	As shown.	2
I	Letters/Numbers	1-1/2" high	As required.
J	Screw Eye	3/4" dia.	As required.
K	Chain	As shown.	As required.

# Colonial Sign Complete Schematic

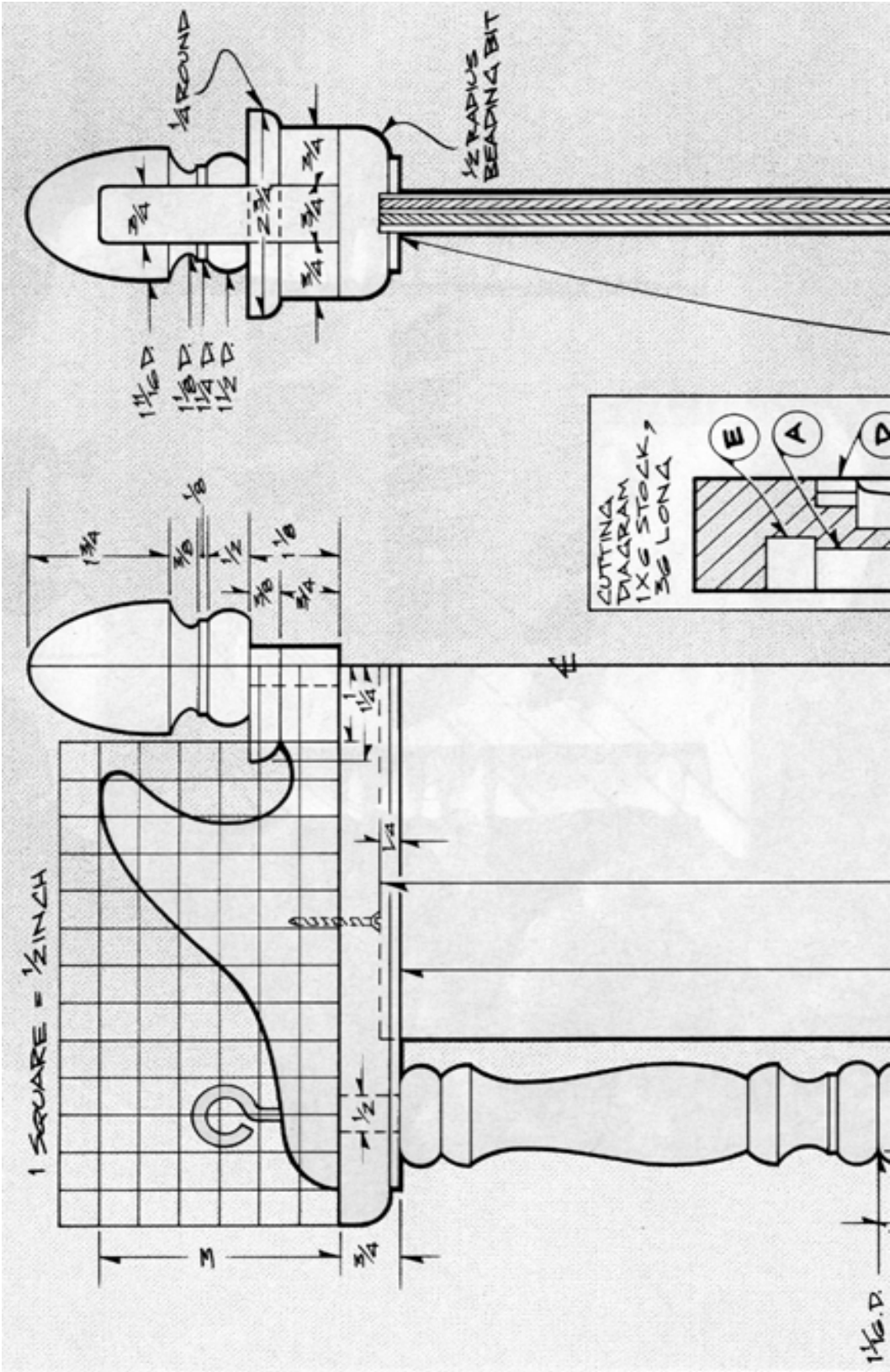

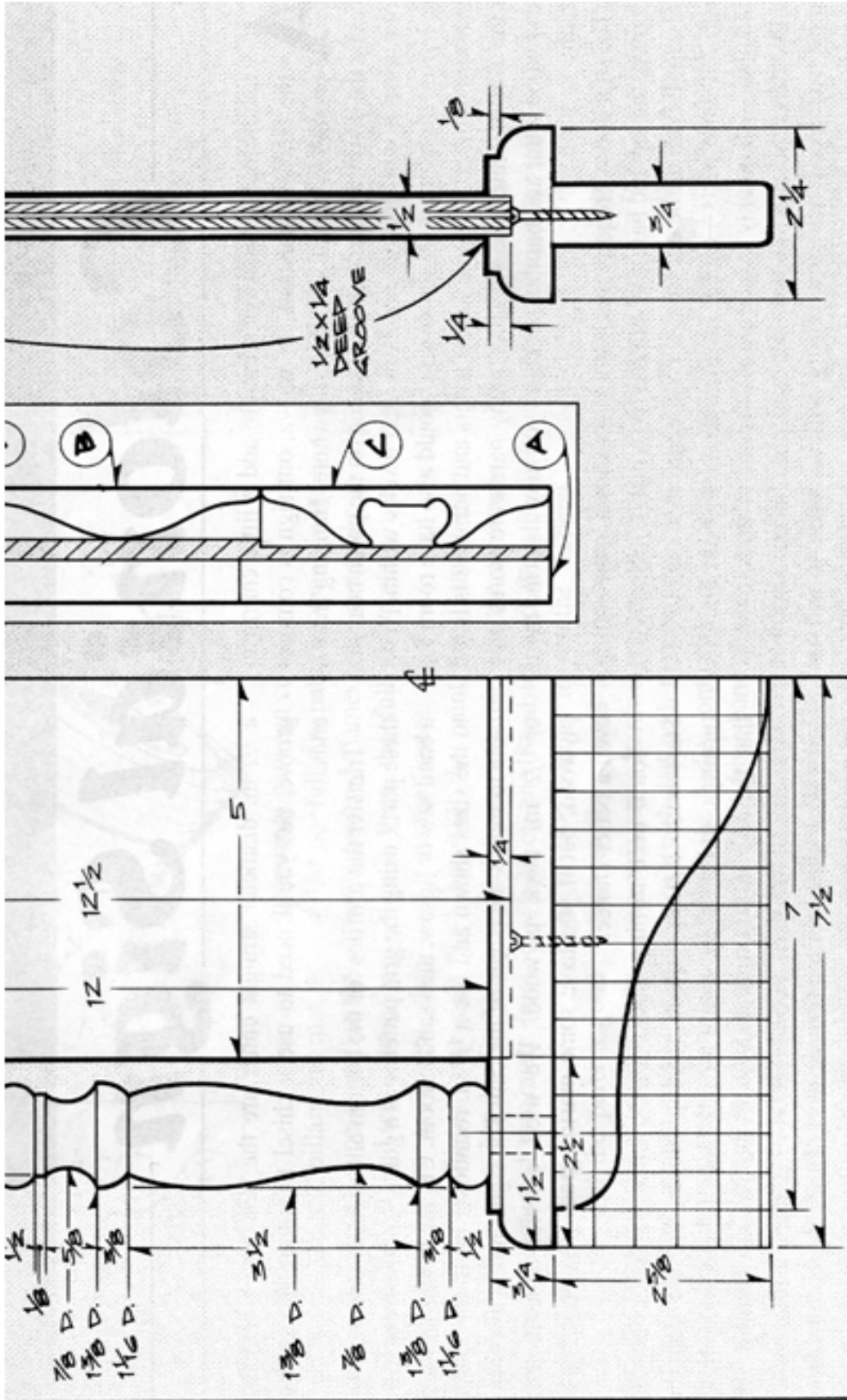

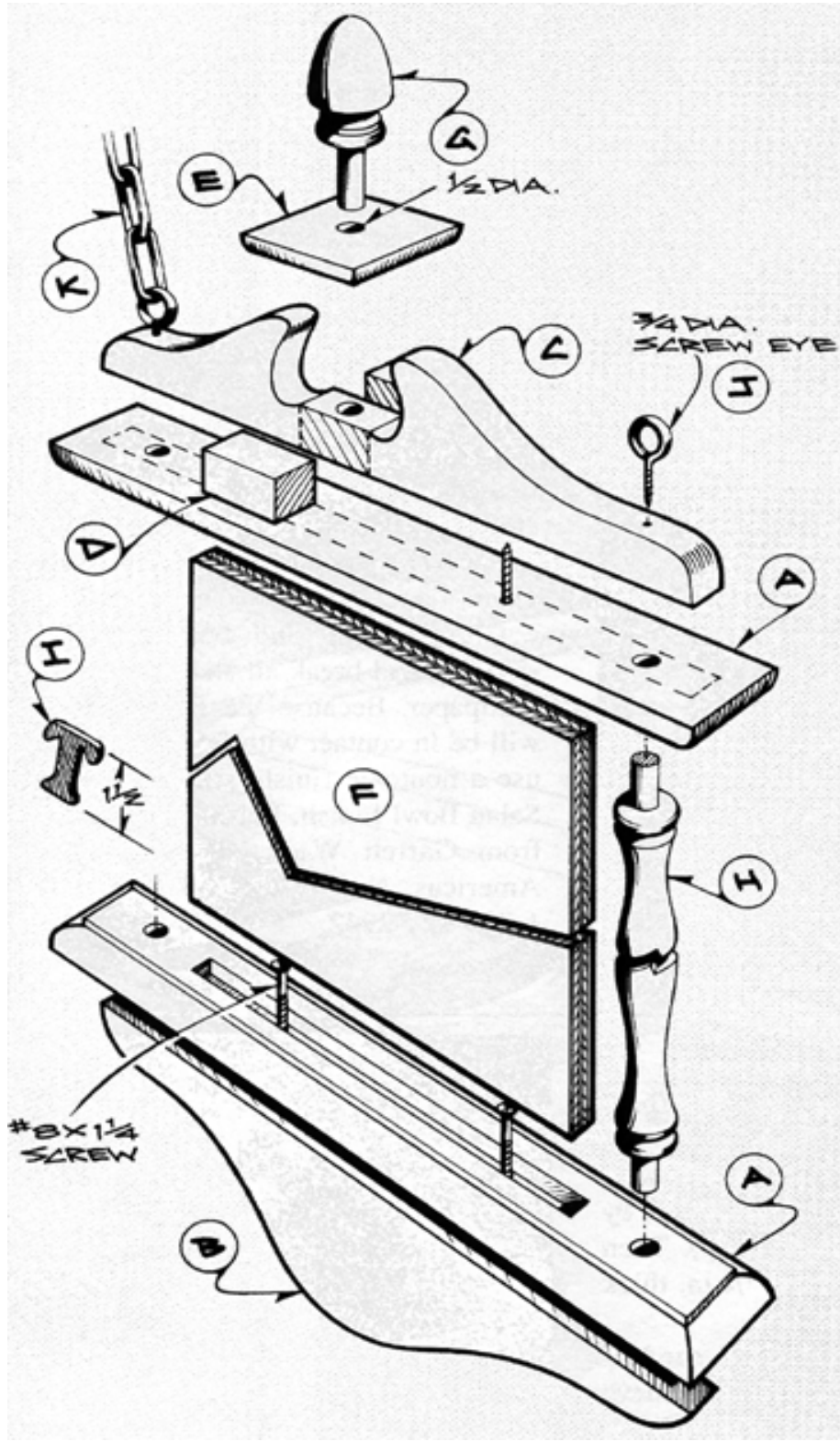

# Colonial Sign Step-by-Step Instructions

1. Select a 3' long 1" x 6" pine board from which to cut top and base (A), bottom (B), crest (C), blocks (D), and cap (E).
2. Cut off a small piece, slightly larger than final size, to make the cap (E).
3. Use a hand plane to reduce the cap to the required 3/8" thickness.
4. Cut the top and base to length and width.
5. Use the router and a 1/2" diameter straight cutter to cut the groove for the signboard (F).
6. Use a chisel to square the groove ends.
7. Drill the column (H) holes.
8. Establish the 1/2" radius stepped roundover all around.
9. Transfer the profiles for the bottom and crest to the stock for these parts, using the grid patterns as a guide.
10. Use a bandsaw or jigsaw to cut out the profiles.
11. Sand the profiles smooth.
12. Cut the blocks and cap to the sizes shown.
13. Use a 1/4" roundover bit in the router table to radius the edges of the cap.
14. Cut the signboard from a section of 1/2" thick exterior construction or marine-grade plywood.
15. Cut a 1-1/2" square turning block for the columns, being sure to include the tenon lengths plus a little extra when you cut the stock the length. **NOTE: The top and bottom halves of the column turning are symmetrical.**
16. Cut a 1-3/4" square turning block for the finial (G), again being sure to include the tenon lengths plus a little extra.
17. Use a combination of gouges, a roundnose, and a skew chisel to shape the columns and finial on the lathe.
18. Final sand the column turnings while still mounted in the lathe.
19. Trim the extra stock for the finial and then smooth the top end after removal from the lathe.
20. Purchase a waterproof epoxy for the sign assembly.
21. Glue the crest and bottom to the top and base. **NOTE: This is a good long-grain glue joint, but to reinforce the joint we added screws inserted through countersunk holes drilled in the groove bottoms (see exploded view).**
22. Glue the two blocks on either side of the crest as shown.
23. Add the cap.
24. Drill for the 1/2" diameter tenon on the finial end.

25. Add the signboard and columns, sandwiched between the top and bottom assemblies.
  26. Paint the sign with a primer coat and then a top coat of white exterior enamel.
  27. Make sure all surfaces are well-sanded, especially the exposed edges of the plywood.
  28. Use auto-body filler or an exterior-rated caulk to fill any voids in the plywood edges.
  29. Add a bead of white silicone caulk to fill gaps at the plywood-in-groove joint after painting, or use a paintable caulk before applying the finish.
  30. Paint the letters and numbers separately before mounting.
  31. Mount the letters and numbers with brads. **NOTE: With a short name you can just run the letters across the sign board, but with a longer name you may need to use a diagonal placement.**
  32. Add some paint over the brad heads to protect them from rust.
  33. Mount the sign with screw eyes (J) and galvanized chain (K). **NOTE: Keep the chain as short as possible to avoid damage should the sign whip about in a windstorm.**
-