

198
GATELEG TABLE



stationary frame so it will not interfere with the movement of the gate leg.

This gateleg table is elegant enough for indoor dining, yet light enough to be carried outdoors when the occasion arises. It opens up to a surface area large enough to accommodate four people and is the perfect project to show off your craftsmanship.

1. Cut the pieces to size according to the dimensions given.

2. Cut 1/2"-deep x 3-1/2"-wide rabbets on the tops of the legs (A). On the same side of each leg, cut 1/2"-deep x 2-1/2"-wide dados 3" up from the bottom.

3. Round and sand the edges of the legs and the back sides of the long bottom and top stretchers (B, C).

4. Assemble the two large frames using glue and wood screws. Round over the edges and sand the faces of the frames.

5. Cut 3/4"-deep x 1-1/2"-wide rabbets in the ends of the short bottom and top stretchers (D, E).

6. Assemble the four small frames, using glue and two screws at each joint. The stretchers should lap the legs and protrude 1/4". Counter-bore and plug the holes; then round over the edges and sand the faces of the frames.

7. Fasten one small frame to the left side of each large frame. The leg on the small frame should sit against the leg on the large frame as shown. To do this, drive two screws from the back through the stretcher into the top and bottom of each leg.

8. Cut 3/4"-deep x 1-1/2"-wide laps in the ends of the bottom and top side stretchers (F, G). Sand the stretchers; then attach them to the frames using glue and screws. Plug the screw holes.

9. Attach the two remaining small frames to the base using butt hinges. This completes the base of the table.

10. Glue up stock for the top and leaf pieces (H, J). The top will overhang the base 1-1/4" on each side to accommodate the hinges.

11. Mount the top to the base by screwing and plugging through the top into the stretchers.

12 Use three hinges to attach each

leaf to the top, making sure that the center hinge is in front of the

13 Sand the entire table and finish as desired.

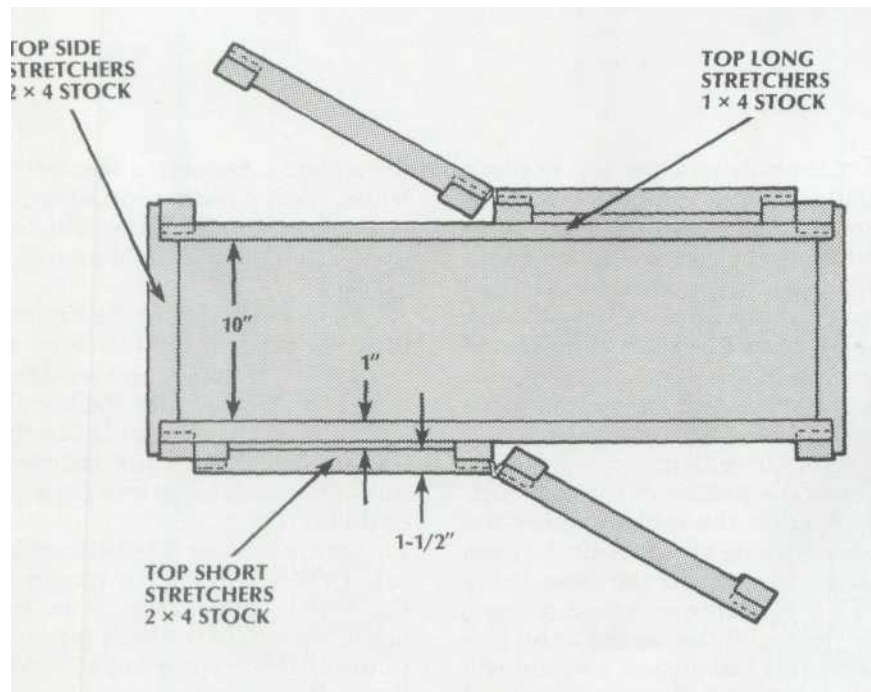

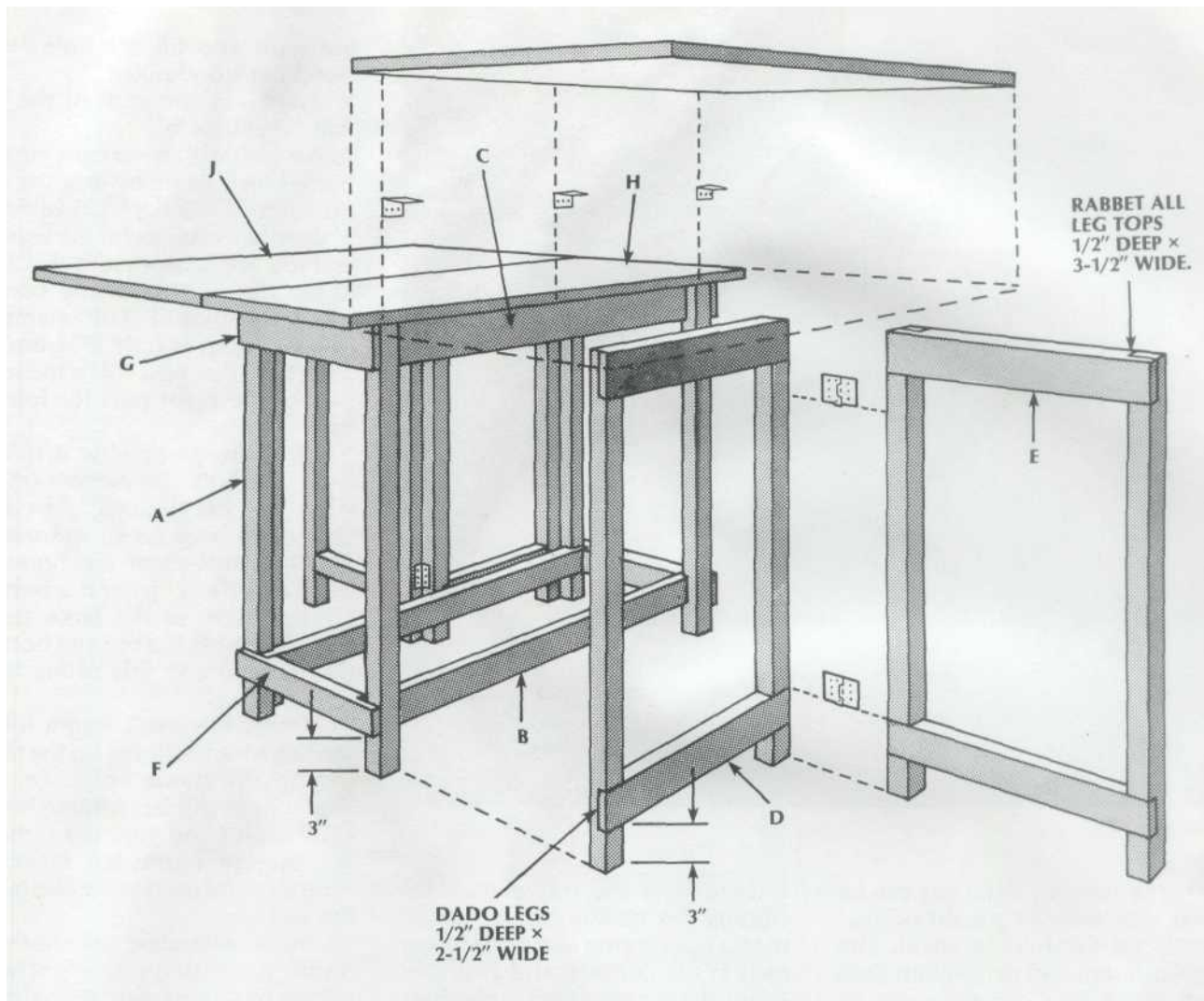

LIST OF MATERIALS

(finished dimensions in inches)

A	Legs (12)	1-1/2 × 1-1/2 × 28-1/2
B	Bottom long stretchers (2)	3/4 × 2-1/2 × 38-1/4
C	Top long stretchers (2)	3/4 × 3-1/2 × 38-1/4
D	Bottom short stretchers (4)	1-1/2 × 2-1/2 × 17-1/2
E	Top short stretchers (4)	1-1/2 × 3-1/2 × 17-1/2
F	Bottom side stretchers (2)	1-1/2 × 2-1/2 × 13
G	Top side stretchers (2)	1-1/2 × 3-1/2 × 13
H	Top	3/4 × 17-1/2 × 47-1/2
J	Leaves (2)	3/4 × 18-1/2 × 47-1/2
	Wood screws	#8 × 1
	Tabletop fasteners	
	Brass butt hinges (7)	1-1/2 × 2
	Wood plugs	
	Wood glue	