

Child's Computer Table

• Introduction

Children with physical challenges can often benefit from time spent on the computer. It is a space

where they have power and are equal to everyone else. They may however need a special computer table built just for their needs. This Child's Computer Table is solid, inexpensive, and can be adjusted in height to accommodate the child as she or he grows. It is easy to build with simple tools and can be build in one weekend for less than \$140.

It features a solid core door table top, a low keyboard shelf, and solid, adjustable legs. The legs are in two parts that can be unbolted and adjusted in height over eight inches in one inch steps.

The prototype, shown above, was made a little differently from the drawing. It was made from materials recycled from dismantling a bunk bed. The top is a piece of MDF with very nice elm veneer. The legs are made from the bed slats which were thin plywood and slightly curved. This table will start life as a changing table for the infant (40 inch height). It will then be used for a child's play table (24 inch height). Later it will be used for a study desk finally a computer desk.

• Detailed Drawings

These construction notes contain the five drawings in bit map format. These down load automatically and print when you print out the text, but they are a bit fuzzy. You can view and print the detailed drawings at out at:

• Sketches

Here are five sketches for this table.

○ Child's Computer Table

At the start of this note is a drawing of the Child's Computer Table. It shows the front and the underside of the door table top. Note the adjustable legs and the keyboard shelf.

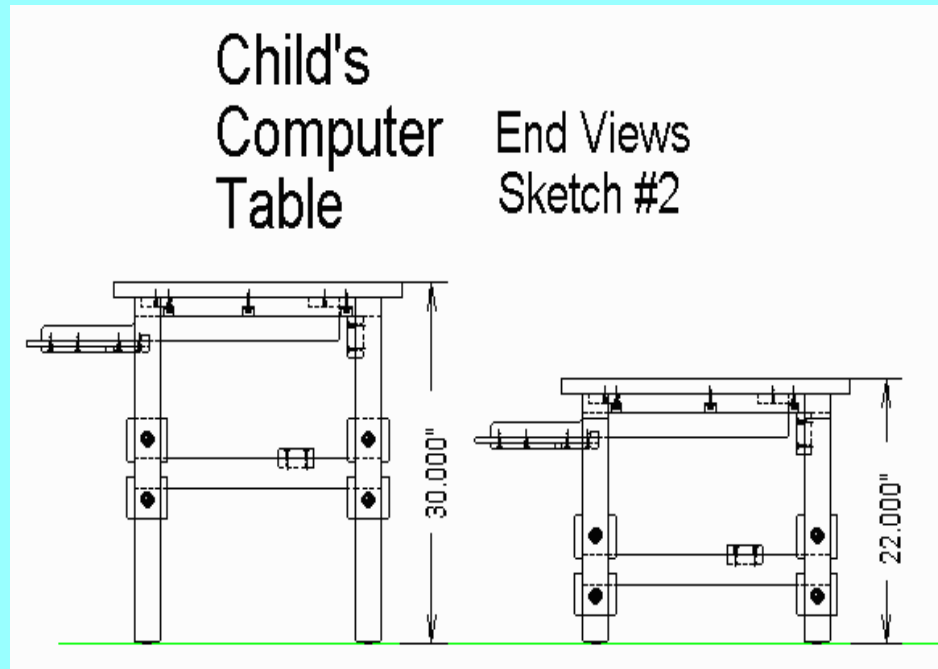

○ Side Views, Sketch #2

This sketch shows two side views. One in the highest position and one in the lowest.

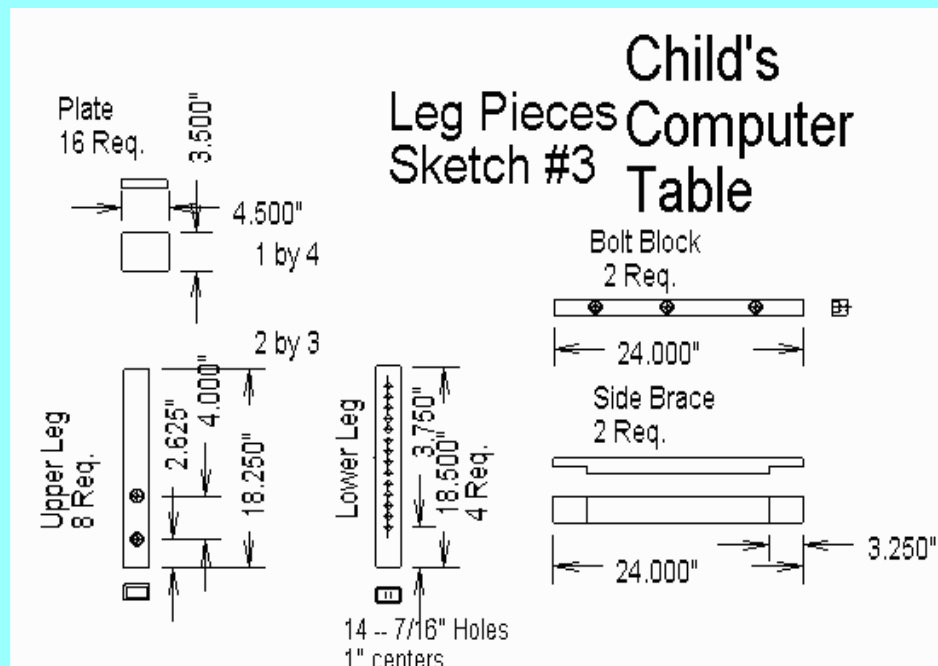

○ Leg Pieces, Sketch #3

Here are the pieces of wood that make up the legs. Most of them are made for 2-by-3 pine lumber. The Plates can be made from 1/2 inch plywood if you prefer.

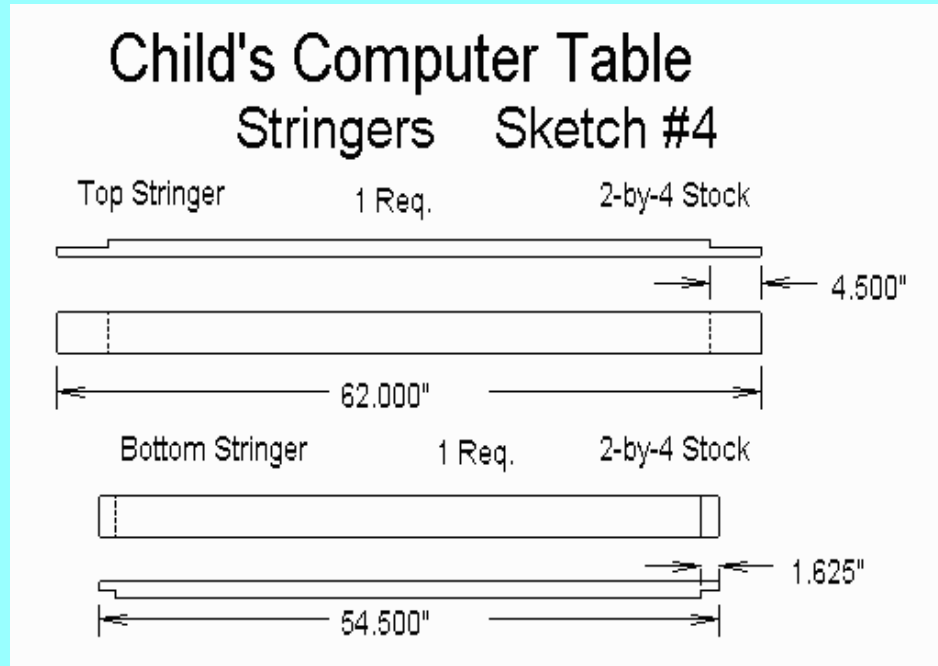

- **Stringers, Sketch #4**

Here are the pieces of wood that run the length of the table. They are shown made from 2-by-4 stock but they could be made from double layers of plywood.

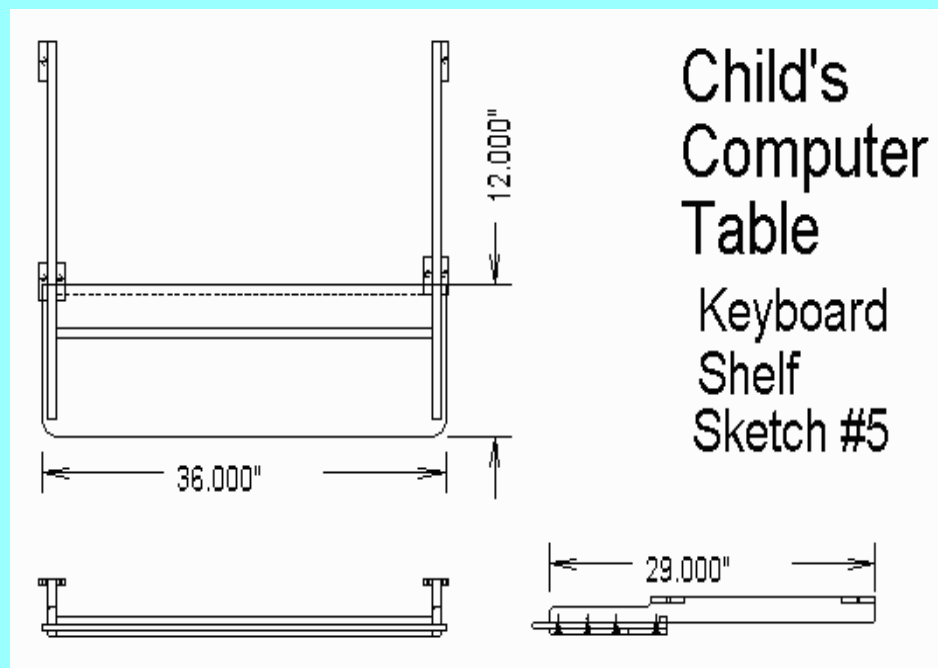

- **Keyboard Shelf, Sketch #5**

This sketch shows three views of the keyboard shelf. It is simply made from 1-by-4's, 5. by .75 inch molding, and plywood.

• **Materials**

You can build this table with the following inexpensive materials:

○ **Wood**

- Solid Core Door, 80 by 28 inches, 1 -- \$ 44.00
- 2-by-3, Pine, 24 feet -- \$ 8.00
- 2-by-3, Pine, 16 feet -- \$ 8.00
- 2-by-2, Pine, 4 feet -- \$ 3.00
- .5-by-.75 inch wooden Molding, 10 feet, \$.32/foot -- \$ 3.20
- 1-by-4 pine, 12 ft -- \$ 7.80
- 1/2 inch plywood, 2 by 4 foot -- \$ 8.00

○ **Hardware**

- 6d finishing nails, 1 pound -- \$ 1.50
- 1-1/2 inch #10 flat head screws, 20 -- \$ 1.50
- 5/16 inch Carriage bolt, 3.5 inches long, 8 -- \$ 3.50
- 5/16 inch Nut, 8 -- \$.50
- 5/16 inch Flat Washers, 14 -- \$.50
- 5/16 inch Lag Bolt 1-1/2 inches long, 6, -- \$ 2.00
- Feet, set of 4 -- \$3.00
- Eye Screws, package -- \$.75

○ **Other Materials**

- Wood Glue 8 oz. -- \$ 3.00
- Stain -- \$ 8.00
- Polyurethane Varnish -- \$ 9.00
- Paint -- \$ 12.00

○ **Omissions and Contingencies**

- Allow %10 for tax, sandpaper etc. -- \$ 12.75

○ **Total -- \$ 140.00**

The secret is to get a good price on the door and lumber.

• Tools Required

You can build this table with the following simple tools. Power tools are not necessary but do speed the work.

- **Saw and Miter Box**

You can do this entire job with a small hand saw and miter box. Their cost new is about \$20.00. If you have a power saw then the work will go faster.

- **Drill**

This can be a hand drill or a small power drill. You will need a couple paddle bits and a #10 screwmate drill bit.

- **Screw Driver**

A match the screws.

- **Wrench**

You need a socket wrench to tighten the bolts.

- **Hammer**

You need a common claw hammer. A small point nail set also helps.

- **Square**

You need a simple square.

• Construction Notes

- **Determine Floor Space**

Determine how much floor space you have for this table. You need to make this decision before buying the materials. It is easiest to leave the door just as it comes from the factory at 80 inches. If you have to cut it down much below 60 inches then you will not have room for a large keyboard and mouse pad together.

○ **Choosing the Door**

You need a solid core door. The cheaper hollow core doors are not solid enough for this table.

The outside of the door may be hardwood veneer or masonite. The Masonite is less expensive and wears better around the edges but does not look as nice. Sealed with shellac, I think it has a nice leathery look.

○ **Cutting the Door to Length**

If you need a table shorter than the full length of door, you can have it cut off at the lumber yard. You might pay a small price for this, but it makes it easier to get home.

If you cut the door yourself, you will need a saw blade with a large number of teeth. Clamp the 1-by-4 to the door for a straight edge and run the saw against it.

The cut edge of a solid core door may have small voids that will need to be filled. Also the cut end will not finish as nicely as the factory end.

○ **Building the Legs**

The legs are built from pieces of 2-by-3 and 1-by-4. The plates can be made from 1/2 inch plywood instead of 1-by-4. Cut the pieces to the lengths shown in Sketch #3.

Counter drill the Upper Leg pieces with a 1 inch drill about 3/4 inch deep. This hides the nuts. Drill the center hole for a good fit on the bolts.

Drill the Lower Leg pieces with fourteen bolt holes on 1 inch centers. These holes should be a loose fit on your bolts.

Round off all edges with a rasp, block plane, and sand paper. Remove any break-out splinters from the drilling. Give the bottoms of the Lower Leg pieces a nice bevel. Sand all sides of all pieces.

○ **Leg Assemblies**

To assemble the legs, bolt the two upper and one lower leg section together with a space of thick paper between them. Index cards or a manila folder work well. Nail and glue on the four plates being careful not to get glue on the Lower Leg piece. Un-bolt and remove

the Lower Leg piece before the glue has a chance to set.

Drill the Bolt Block with counter sink holes like the Upper Leg piece and loose bolt holes for the lag bolts.

Attach the Bolt Block and Side Brace to two legs with nails and glue. You may need to adjust the notches in the Side Brace to suit your materials. Be sure that the assembly is square.

○ **Base Assembly**

Cut the two stringers shown in Figure #4. You may need to adjust the length of the end notches to suit your materials.

Attach the stringers to the leg assemblies with screws only. These joints are not glued so that the base can be taken apart for moving. A Screwmate drill is really a must to drill the holes for these screws.

Place newspapers or magazines on the floor for protection and put the door on them. Place the best side down. Position the base assembly on the door make sure that it is even front-to-back and side-to-side. Check the square.

Mark one lag bolt hole. Move the frame aside and drill this hole. Be very careful that you do not drill through the table top. Placing a masking tape flag around the bit at the right depth helps.

Slide the base back in place and loosely install the first lag bolt and washer. Recheck the base location and square. Mark all the rest of the lag bolt holes and drill them the same way.

○ **Keyboard Shelf**

A low keyboard shelf is very important to reduce stress in typing. The shelf shown in Sketch #5 is made from 1-by-4's, 1/2 inch plywood, and .5-by-.75 molding.

You can substitute other materials. For example, two thickness of easy to obtain 1/4 inch plywood can be glued together. If you have a table saw you can cut your own .75 by .75 blocks to replace the molding.

It is important that the front corners of the shelf be well rounded as they get bumped into.

The 1-by-4 lumber comes 3.5 inches wide. You can cut or plane it down to 3.125. This is plenty of height for even large keyboards.

Cut the nose of the two 1-by-4's into a pleasing shape with rounded corners and edges.

Assemble the shelf with screws and glue. Install the screws up through the molding and plywood, and into the supports. You can use #8 screws if you like. The two long cross pieces of molding help stiffen the shelf. They are cut to fit and are held on with glue and brads.

The six screw blocks are then pre-drilled for the screws, and glued and nailed to the supports.

○ **Final Assembly**

Re-install the Lower Legs pieces without the paper spacers.

Sand the entire shelf assembly and position it on the upside-down table. Install it with six screws but no glue. Again it may need to be removed for moving.

○ **Little Extras**

You can add a few eye screws to the under side of the door to tie up your computer cables. Small block of the .5-by-.75 molding nailed to the back edge of the table can help keep it from crushing computer cables against the wall.

○ **Finishing**

Remove the base, shelf assembly, and Lower Leg pieces for finishing. Round all corners with a block plane, rasp, and sand paper. Round the edges and corners of the door top.

If you cut the door down, work wood filler into the cut edge. Let it dry thoroughly and sand.

It is up to you how to finish the table. It looks good with the top and keyboard shelf stained and varnished. The top edges, entire base, and shelf supports can be painted a nice solid color.

• **Conclusion**

Congratulations, you have complete a good, low-stress computer table. This table is an important part of your plan to reduce computer use stress.