

# Mendocino Bench

## FREESTANDING BENCH

The clean, horizontal lines and rich redwood tones of this bench design reflect the simple beauty of Northern California. Comfortable and elegant with a gracefully curved seat and angled backrest, it offers a standing invitation to sit, relax and enjoy.

For both the Freestanding and the Built-In Railing Benches, use Construction Common or Deck Common, redwood grades that have a pleasing mix of heartwood and sapwood. Where increased decay resistance is needed, use all-heartwood grades: Construction Heart or Deck Heart.

Build the 6-foot Freestanding Bench in the following order. Use only corrosion-resistant deck screws to prevent staining. Counter-sink and plug screw attachments.

**1. Armrests** Trim the front end of each 4x6 armrest at a 45° angle, beginning 1½ inches down from top. Notch the inside back of each armrest where it will wrap the rear leg. Finish with a 45° bevel cut. See armrest detail.

**2. Legs** Using 4-inch screws, attach armrests to 4x4 rear legs 24 inches up from the bottom. Attach armrests to front legs by driving two screws through the armrest and into the top of the leg.

**3. Main braces** Trim 2x4s for the main braces and attach to inside front and rear legs 11 inches from bottom.

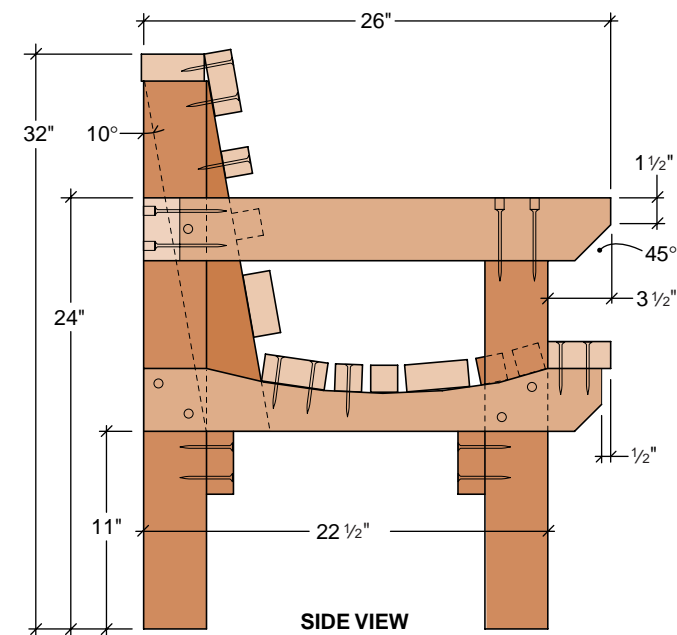
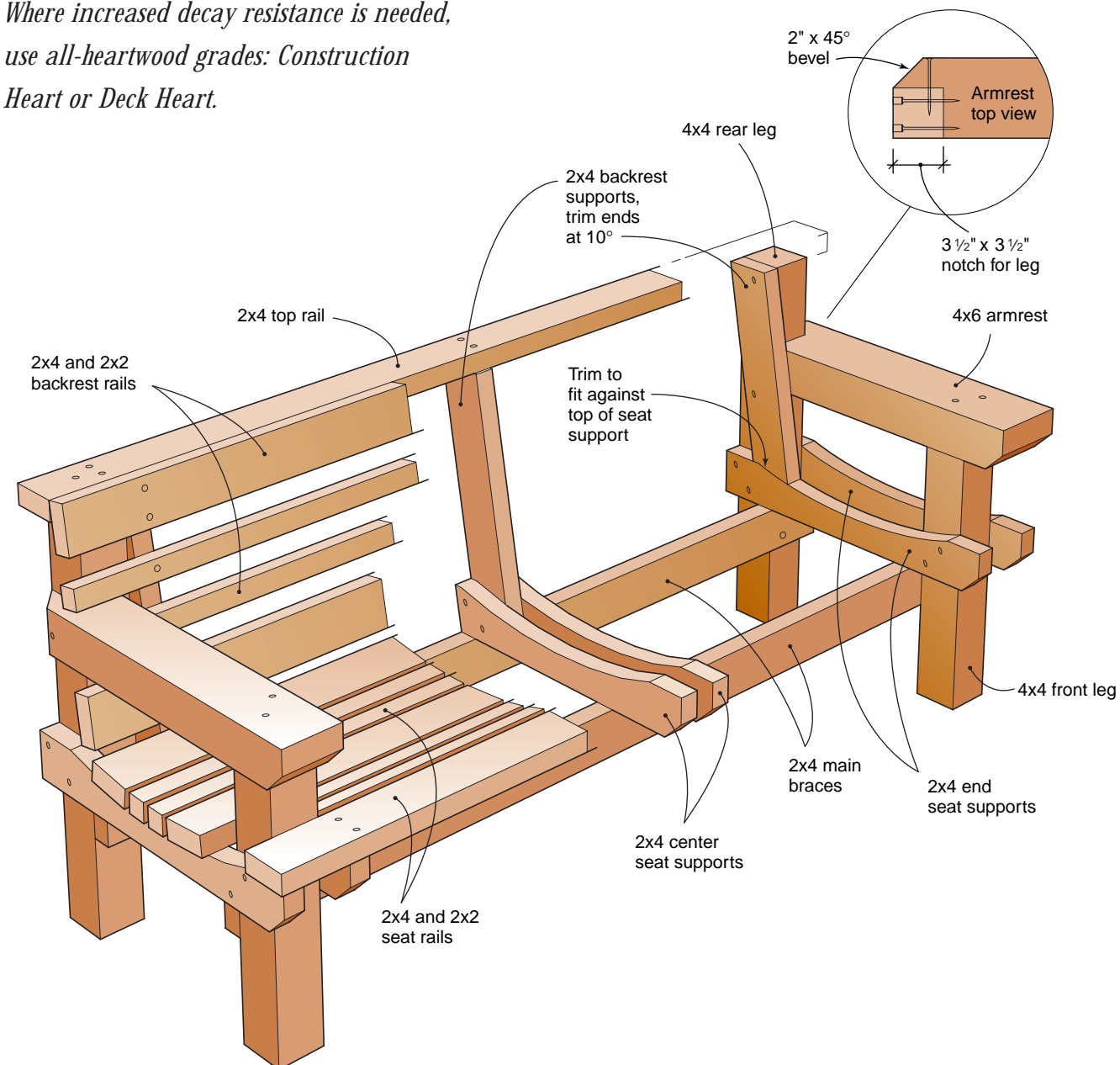

**4. Seat supports** The curved seat supports are made up of 2x4 lumber sandwiching either the 4x4 rear legs or the single 2x4 backrest support. To shape the curve, make a template for a 36-inch radius cut. Mark the cut to start 3 inches in from the front. Use a bandsaw to cut the radius to a depth of no more than 1¼ inches. Finish the seat supports with a 45° bevel cut to match the armrests.

Note that the end and center seat supports differ slightly in length and attachments.

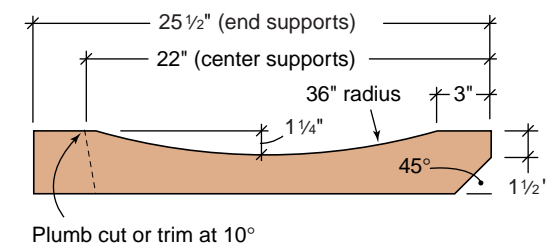

**End seat supports** Trim four 2x4s to 25½ inches. Attach the inside seat supports to the rear and front legs so they rest on the top edge of the 2x4 main braces. Attach the outside seat supports level with the inside ones.

**Center seat supports** Trim the two center seat supports to 22 inches. Using a scrap piece of 2x4 as a temporary spacer for the backrest, attach these seat supports across the main braces flush with the back edge of the rear brace. Use two 3-inch screws for each joint, angled from below and inside. Remove the spacer.

**5. Backrest supports** Trim the 2x4 backrest supports to a 10° angle at the top edge. The two end backrest supports start at the top of the 4x4 rear leg and trim to rest on top of the seat supports. The center backrest trims flush to the bottom edges of the two center seat supports.

Attach the end backrest supports to the inside of the 4x4 rear leg with two screws. The bottoms should fit snugly to the top of the seat supports and can be secured with screws driven at an angle from below.

You should install the top rail before trimming and attaching the center backrest.

**6. Top rail** Attach the 2x4 top rail to the rear legs with three deck screws at each end. Measure and trim the center backrest. Install between the seat supports and flush to the underside of the top rail. Secure with screws.

**7. Seat and backrest rails** Trim one 2x2 backrest rail to fit between the armrests. Trim the other 2x2 and 2x4 seat and backrest rails to six feet.

Install the front seat rail so that it overlaps the seat support by ½ inch, and attach with two deck screws at each joint. Attach the rear seat rail to each support with two deck screws. Adjust the spacing of the remaining seat rails before attaching.

Space the backrest rails equally, and attach to supports with a single screw at each 2x2 and two screws at each 2x4.

### Materials For 6-Foot Freestanding Bench

	Quantity	Size	Length
Top, seat and backrest rails	6	2x4	6 feet
Seat and backrest rails	6	2x2	6 feet
Main braces	2	2x4	5 foot 9 inches
Seat and backrest supports	9	2x4	26 inches
Front legs	2	4x4	20½ inches
Rear legs	2	4x4	30½ inches
Armrests	2	4x6	26 inches
Deck screws	1-1½ pounds		3 and 4 inches

## BUILT-IN RAILING BENCH

This open-ended bench design adds comfortable railing seats to a new redwood deck. Plan to begin construction before finishing the deck board installation to allow access to the deck framing. If the deck surface is more than 30 inches from the ground, the top rail of the bench must be at least 36 inches off the deck or be in compliance with your local building code.

These plans are based on a 4-foot-long bench section. You can easily build a longer bench by adding a post for each additional 4 to 6 feet of bench length. Seat supports and legs are required every 2 to 3 feet.

The Built-In Railing Bench differs from the Freestanding Bench in several ways: it has no armrests and the seat supports are made from 4x4 lumber. Construct the Built-In Railing Bench in the order shown.

**1. Posts and legs** Install the 4x4 posts with machine bolts. Each post extends from the deck framing and is attached to either the rim joist or the deck joist with two 1/2-inch by 6-inch machine bolts. See section detail.

### 2. Seat supports

Follow the instructions for the Freestanding Bench seat supports to measure and cut the curved seat radius. Trim all the 4x4 seat supports to 22 inches. Attach them to the front and rear legs using three 4-inch screws driven from the top.

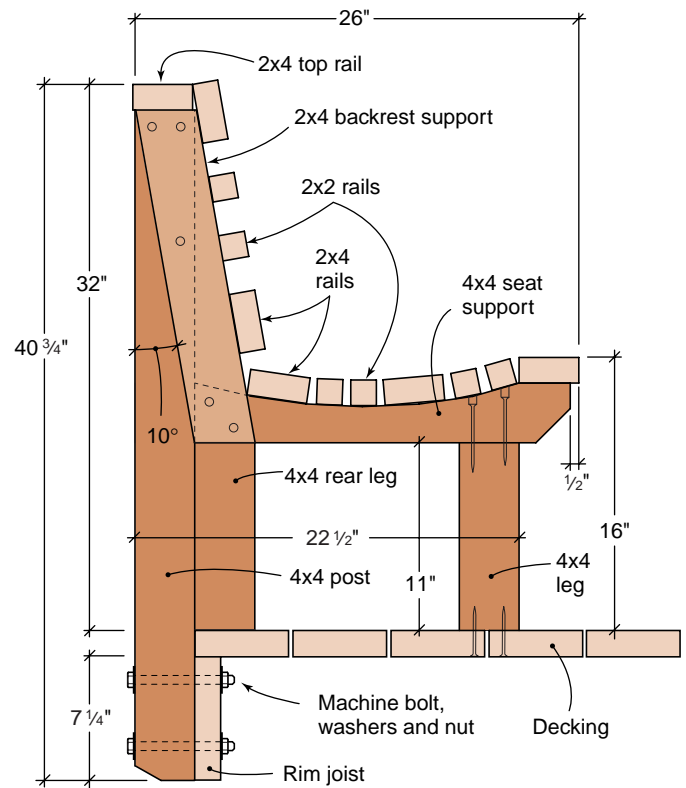
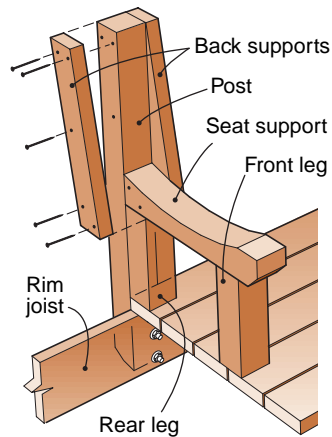

**3. Backrest supports** Trim both ends of each 2x4 double backrest support to 10°. Attach flush to the top of each 4x4 post and to the 4x4 seat supports.

**4. Top rail** Trim the 2x4 top rail to length and attach to posts with screws. Use bevel cuts at any butt joints to minimize gapping.

**5. Seat and backrest rails** Trim 2x2 and 2x4 seat and backrest rails to length and attach as described in the Freestanding Bench.

### Materials For 4-Foot Built-In Bench Section

	Quantity	Size	Length
Top, seat and backrest rails	6	2x4	4 feet
Seat and backrest rails	6	2x2	4 feet
Backrest supports	4	2x4	2 feet
Seat supports	2	4x4	26 inches
Front and rear legs	4	4x4	11 inches
Posts	2	4x4	39 1/4 inches
Deck screws	1-1 1/2 pounds		3 and 4 inches
Machine bolts, washers and nuts	4 sets		1/2 x 6 inches

Contact the California Redwood Association for more great publications containing redwood technical and building information. Call us at 415 382-0662 for a complete literature list or to ask for any of the titles listed here:

#### Other Construction Tipsheets

Deck Over Concrete  
8x10 Deck  
Deck Around Tub  
Shade Shelter  
Butcherblock Bench  
4x4 Planter  
Sonoma Picnic Table  
Lake Tahoe Gazebo

#### Also Available

Deck Construction  
Deck Grades, Nails and Finishes  
Design-A-Deck™ Plans Kit  
Fences for All Reasons

## ***Redwood***

For beauty and performance, redwood is naturally superior to other woods. That's why it's the first choice for decks, fences and most outdoor projects. Redwood retains its beauty outdoors, shrinks and swells less than other woods and is less likely to warp, split, check or cup. With little or no pitch, redwood is easy to drill, saw and shape. Redwood heartwood has natural durability and resistance to insects and will last longer outdoors than most woods.

## ***Grades***

The knotty garden grades of redwood are ideal for outdoor projects. These grades are beautiful, durable and economical.

***Construction Heart/Deck Heart*** is all heartwood and contains knots; used for load-bearing applications near the ground. Deck Heart is graded for strength and is available in 2x4 and 2x6.

***Construction Common/Deck Common*** contains sapwood and knots; used for decking and above-ground uses. Deck Common is graded for strength and is available in 2x4 and 2x6.

***Merchantable Heart*** is all heartwood and contains larger knots than Construction grades; used near the soil.

***Merchantable*** contains sapwood and larger knots; used for fence boards, rails and above-ground uses.

## ***Finishes***

Redwood accepts finishes better than most woods. Some heighten redwood's natural beauty, bringing out the color and the grain. Others help the wood harmonize or contrast with surrounding structures. Keep in mind that unfinished redwood will gradually turn soft driftwood gray. Read the labels on all finish products before using.

***Clear water repellent finish*** is recommended to stabilize the color at tan.

***Semitransparent stains*** in "redwood" shades tint the wood without hiding the grain.

***Solid-color stains or paints*** should be applied over compatible oil-based primers.

## ***Fasteners***

Use only non-corrosive hardware such as aluminum, stainless steel or top quality hot-dipped galvanized screws or nails. Ordinary nails and screws will cause stains.

