

78

# GLOBE STAND





You might prefer a tapered-leg taboret with wedged tenons...



...or a globe stand in the style of Frank Lloyd Wright...



...or even in the style of a Gustav Stickley end table.

## ARTS & CRAFTS GLOBE STAND

NO.	ITEM	DIMENSIONS (INCHES)			MATERIAL
		T	W	L	
□ 4	Top pieces	$\frac{3}{4}$	$5\frac{5}{16}$	$14\frac{1}{2}$	Cherry
□ 2	Table pieces	$\frac{3}{4}$	5	10	Cherry
□ 4	Legs	$1\frac{1}{2}$	$1\frac{1}{2}$	$29\frac{3}{4}$	Cherry
□ 2	Stretchers	$\frac{3}{4}$	$2\frac{1}{2}$	18	Cherry
□ 4	Corbels	$\frac{3}{4}$	$\frac{7}{8}$	9	Cherry

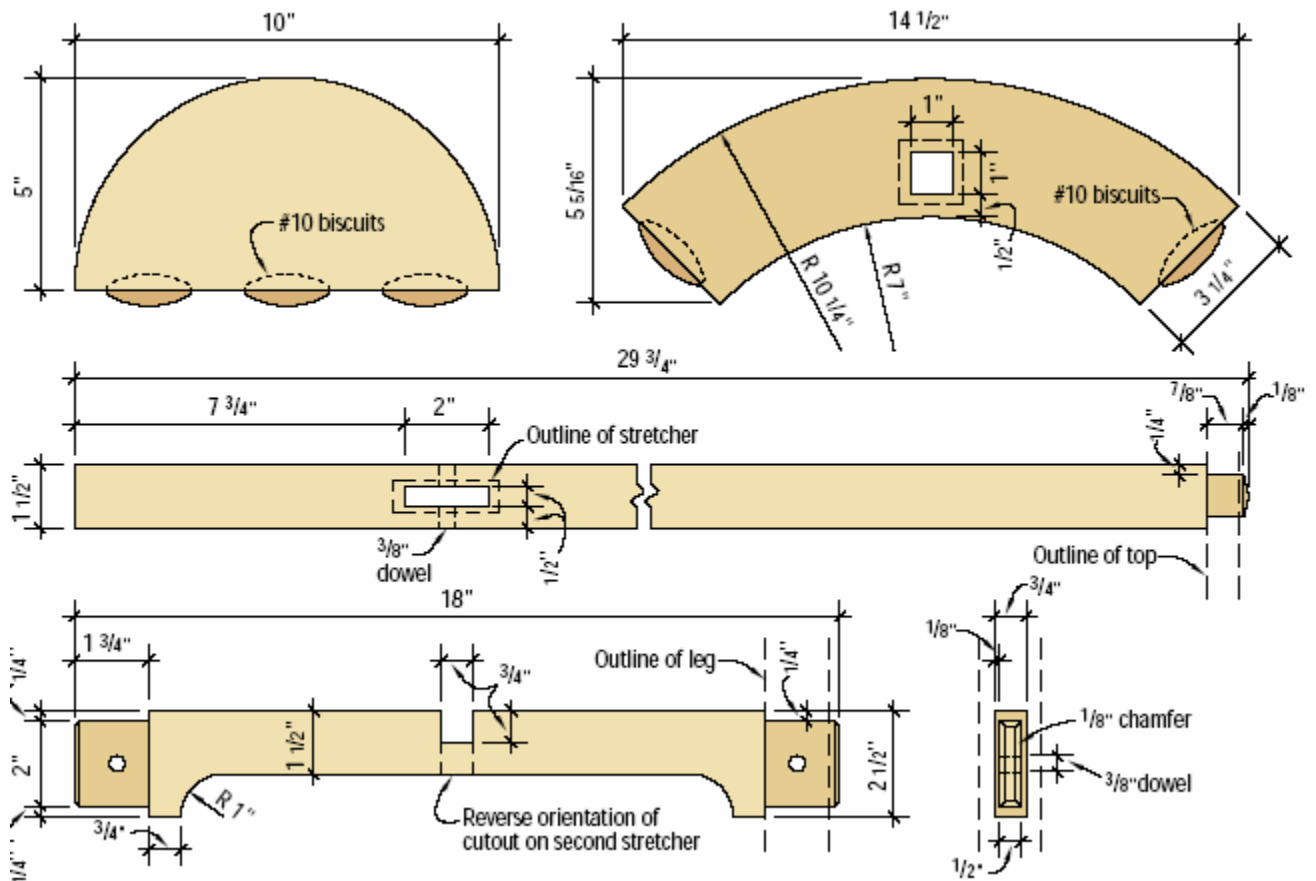

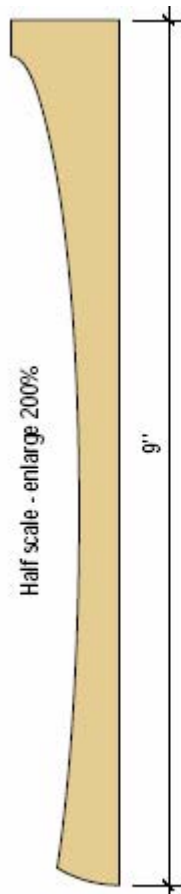

## Around the World in Four Easy Pieces

Start by laying out the four top quadrants. With the exception of the legs, all the parts for this project are sized to be cut from 1 x 6 stock. Before turning to your band saw to test your eye/hand coordination on the outside curves, cut the 1" x 1" mortises. They're easier to form when there are still flat sides to press against a fence.

While splined joints might have been another "trick" that I could have thrown into the mix, I opted for the ease and familiarity of biscuits when assembling the ring. After gluing up the ring, cut the arcs slightly wide of the line on the band saw. I used a shop-made circle-cutting jig on my router table to refine the outside edge. Then I used a router edge guide to trim the inside edge to a perfect circle.

I also used biscuits to join the two halves of the lower table. I added another level of detail with a 1/4" x 1/4" chamfer on the top edge of both the ring and table. Finally, I plowed two 1/4"-deep x 3/4"-wide grooves that crossed in the middle of the bottom of the table to position it squarely on the stretchers.

The legs are formed from 2 x 2 stock. Although the 1/2" x 2" through-mortises were made on the legs with a straightforward series of cuts with a 1/2" mortising chisel, the through-tenons required some attention to detail. After cutting the tenons on the ends of the legs to fit the mortises, I determined that a 14° bevel would give me an 1/8"-high pyramidal top. The tenon is sized to allow for an 1/8" vertical rise above the top before transitioning into the slopes. I like the look, and it's more forgiving than trying to align four pyramid bases exactly with the tabletop.

The stretchers are joined with a simple half lap. The ends of the through-tenons are chamfered at a 45° angle. I then pegged each tenon using 3/8" cherry dowels through



Use the plans from the diagrams to lay out your mortises on your top pieces. Draw the mortise locations on paper, photocopy the plans and use rubber cement or a spray adhesive to attach them to your wood. Then it's simple matter of cutting where the lines tell you to.



After you've cut your top to size, you need to clean up the band-sawn edges using a router table, a straight bit and the shop-made jig shown here. First cut a piece of 1/4"-thick plywood to the same size as your top and attach it to the top using a spray adhesive. Nail the center of the 1/4" plywood to a sub-base of 3/4" plywood. My router table is part of my table saw setup, so I attached a miter bar to the 3/4" plywood, which allowed me to slide the jig into position. If you don't have a miter slot, you

23/64" holes after slightly tapering the ends of the dowels. With the holding power of contemporary glues, they're only for show anyway.

Speaking of show, the corbels that "support" the top are structurally unnecessary to this project. Visually, however, they're the icing on the cake. Glue them in place and clamp them up.

To mount the globe on the stand, you need to cut two 1/4"-long x 1/4"-deep notches in the inner edge of the ring. Rather than setting up my router and a jig for the operation, I chucked a 1/4" Forstner bit into my drill press, made a 1/4"-deep hole that was tangent to the inner edge, and squared up the bore with a sharp utility knife. See the photo at left for details.

Because cherry darkens quickly enough through oxidation and exposure to ultraviolet rays, I used a clear wipe-on oil finish to emphasize the contrast between the end grain of the through-tenons and pegs and the face grain of the legs and top. If you've got 'em, you might as well flaunt 'em.

might need to first clamp the jig in place and raise the router bit while it's running to get your cut started.



Once you get the outside shaped perfectly, you can use that edge to guide your router. I used a commercial edge guide (the [Micro Fence](#)). Essentially, two rounded guides ride along the outside edge of the top, ensuring the straight bit cuts a perfectly circular path. You also could make this cut using a commercial or shop-made circle-cutting jig for a router.



Though there are many complicated ways to attach corbels to legs, I prefer to simply glue and clamp them in place.



Here's a close look at the notches in the top that hold the pins on the globe.