

“Get A Ball” Out of Your Woodworking



One of the greatest things about having a woodworking shop is this: When you get an idea for a project (no matter how “goofy” it may seem), you can go into the shop and “have at it”! And the best part of all is that a woodworking shop is not only a great place to build a project . . . it’s a fantastic place for stimulating ideas, as well! Don’t you just love woodworking?

MARK V owner Troy Todd found this situation to be true for him, as well, when he created this unique, whimsical **Wooden Gumball Machine**.

Here’s how to make one (refer to the assembly drawing for all part references):

1. Cut out the stock. Follow the list of materials at the end of the article. For best results, we suggest you use a hardwood such as cherry or maple. Cut the round discs (A thru E) using your bandsaw or scroll saw and mark the center of each piece clearly.

2. Drill a 1/4-inch hole in the centers of parts A through E. Mark the part letters on pieces B through E. Now, make the simple clamping jig shown in Figure 1 from a 3/4-inch x 8-inch piece of stock and a 1/4-inch-20 x 3-inch pivot bolt.

Next, stack discs B, C and D over the pivot bolt on the jig with disc B on the bottom. Lay the jig flat on the surface of your MARK V Drill Press Table, with the stacked discs clamped in position with 1/4-inch-20 nut and washer so they won’t rotate.

Locate a point 3/4-inch in from the center of your discs and drill a 5/8-inch diameter hole. Set your drill press stop to drill all the way through discs D and C . . . but only half-way through disc B. Drill your 5/8-inch hole.

3. Rout the slide lever slot on disc C by first marking off the 2-3/4-inch arc on the edge of the disc. Tilt your MARK V’s table 90-degrees so its surface is parallel with the machine’s way tubes, then clamp the jig to the table surface as shown in Figure 1 . . . so the point of your drill bit is in exact left-right alignment with the centerline of your pivot bolt.

Mount disc C over the pivot bolt and drill a 1/4-inch diameter by 1-inch deep hole at each end of your drawn arc. Next, use your MARK V's Router Attachment with a 1/4-inch Bit to rout a 1-inch deep groove, connecting the two 1/4-inch holes you just drilled.

Caution: Do this in shallow, 1/8-inch deep passes to ensure the smoothest slot.

4. Cut out the center of disc C with a 2-1/2-inch hole saw or scroll saw. While you're at it, also cut out the center of the body piece (E) and set piece E aside.

Now, take the center (scrap) stock you just cut out of disc C and clamp it down over the jig pivot bolt. Drill a 1/4-inch diameter x 3/4-inch deep hole at the centerline for the slide lever, next to the 5/8-inch vertical hole as shown in Figure 2.

5. Chamfer the 5/8-inch diameter holes on discs C & D. Use your Drill Press with a 1-inch countersink bit. Also locate and create a countersink "dimple" on piece A to catch the gum ball as it exits the hole in the side of disc B.

6. Drill a 5/8-inch diameter hole for the gum return on disc B. Use your MARK V in Horizontal Boring mode, with the jig clamped to the table surface as shown in Figure 3. Tilt the table 5-degrees so your bit exits through the surface of the disc as it approaches the center.

Continue . . .



Figure 2

Clamp the center disc (scrap from Ring C) to the jig and drill the slide lever hole.

(Click on blue link



Figure 3

Tilt the table 5-degrees and drill the gum return with the Horizontal Boring Machine.

(Click on blue link

*above for a larger
version of the
image)*

*above for a larger
version of the
image)*

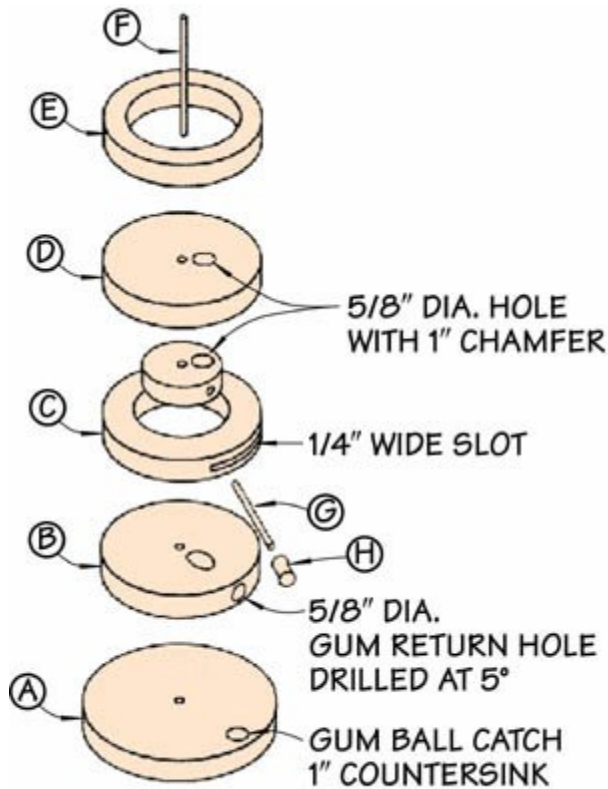

List of Materials
(finished dimensions in inches)

A	Base Disc	6-1/4 dia. x 3/4
B	Body Disc	4-3/4 dia. x 3/4
C	Body Ring	4-3/4 dia. x 3/4
D	Body Disc	4-3/4 dia. x 3/4
E	Top Ring	4-3/4 dia. x 3/4
F	Center Pin	1/4 dia. x 4 dowel pin
G	Slide Lever Pin	..	1/4 dia. x 2-1/2 dowel pin
H	Slide Lever Knob	..	3/4 dia x 3/4 dowel pin

GUM BALL MACHINE ASSEMBLY

**1/4" x 3" STOVE BOLT
(NUT AND WASHER
NOT SHOWN)**

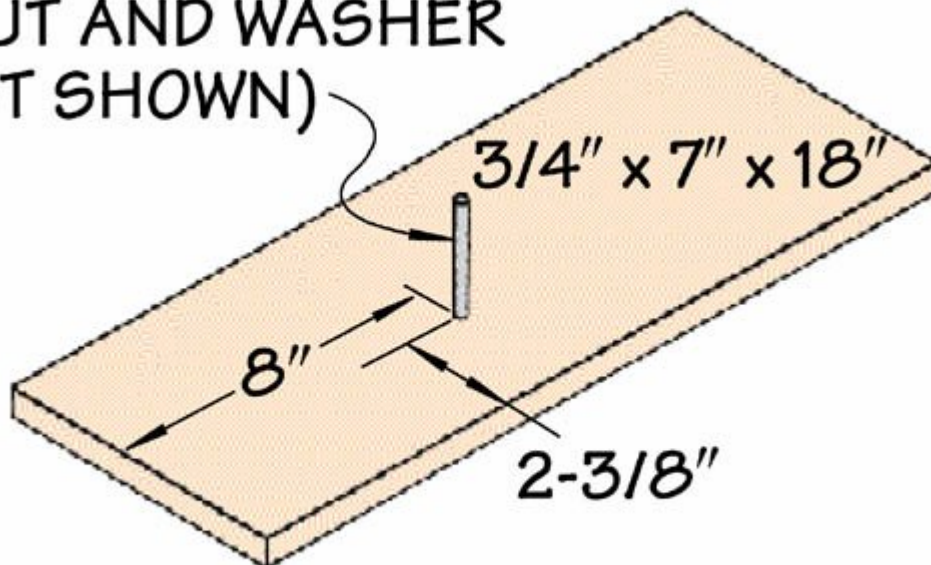

CLAMPING JIG