

29

BENTWOOD BOX WITH SNAP-FIT LID

Walnut, Hard Maple



MAKING THE BENTWOOD BOX

Work begins with the construction of a bending form for the main body of the box. Mine consists of a stack of spruce 2 X 4's laminated together and band-sawn and sanded to the box's inside profile. On the side of the form that will shape the front of the box, the face of the form is undercut for the lap of material beneath the box's glue joint. A thin strip of metal (in my case, aluminum siding) is screwed to the form creating an opening into which the end of the sidewall material can be slipped as that material is wrapped around the form.

The next step is acquiring material for the sidewalls of the box (see chapter two for a detailed discussion).

After the sidewall material has been soaked (for twenty-four hours in cool water, followed by ten minutes in warm water), wrapped around the form, and clamped in place, it should dry for four or five days. At that time, remove it from the form and cut the lap joint. For this particular example, I drilled three holes in the joint, sandwiching in three bits of peacock feather between the lapping laminations so that the feather was visible through the holes. The joint is then glued and clamped using the bending form and the caul both to protect the material from the clamps and to preserve the box's oval shape while the glue cures. (this process is described in some detail in chapter two).

Cut out the clasps and the handle next. Thicknesses can vary, but the thickness of the clasps must be accurately transferred to the stock that will later become the lid so that the walls of the notches fit snugly against the clasps.

When you have selected the lid material, place the box's bentwood sidewalls on that material and draw a line around its circumference. Next, establish a centerline running from one end of the box to the other. This centerline is necessary in order to lay out the notches that will house the clasps.

Next, sketch the outside profile of the lid. There is considerable freedom in establishing this profile since the notch placements are the only critical locations on the lid. Then cut the lid's outside profile on the band saw.

Once the lid has been shaped, the handle is affixed. I taped the handle in place, turned the lid over, and drove a couple of wood screws up through the lid and into the handle.

Make the bottom next. After thickening the stock to 7/16", place the box's bentwood sidewalls on the bottom

MATERIALS LIST

A	Top	1 pc.	1 × 7¼ × 15½
B	Sidewall	1 pc.	½ × 3½ × 30
C	Bottom	1 pc.	7/16 × 6¼ × 8½
D	Clasps	2 pcs.	½ × 1½ × 7¼
E	Handle	1 pc.	¾ × 1¾ × 6¾

**Measurements for lid, bottom and clasps must be taken from the dimensions of the sidewall, which are, in turn, determined by the size of the bending form.*

material. Profile the inside and outside of the sidewalls. On the band saw, cut the bottom profile, keeping the saw kerf approximately 1/16" outside the pencil line that marked the outside circumference of the sidewalls. Then, clamping the bottom in a vise, cut away the extra 1/16" of material with a block plane, to remove the saw marks.

Mark the rabbet around the bottom circumference with a line 5/16" from the top surface of the bottom. Next, with a dovetail saw, make a shallow cut along that line. This saw kerf represents the bottom of the rabbet. With a chisel, cut the rabbet to the depth marked by the line traced around the inside face of the sidewalls. Once the bottom has been fit, sand the parts and assemble the box using 1/8" wooden pegs to both fasten the walls to the bottom and the clasps to the walls.

OPENING THE BOX



1 Place your thumbs on the tops of the box's clasps while your fingers grasp the fishtail ends of the lid. Spread open the clasps and lift the lid. To close, press the lid down against the clasps until it snaps into place.

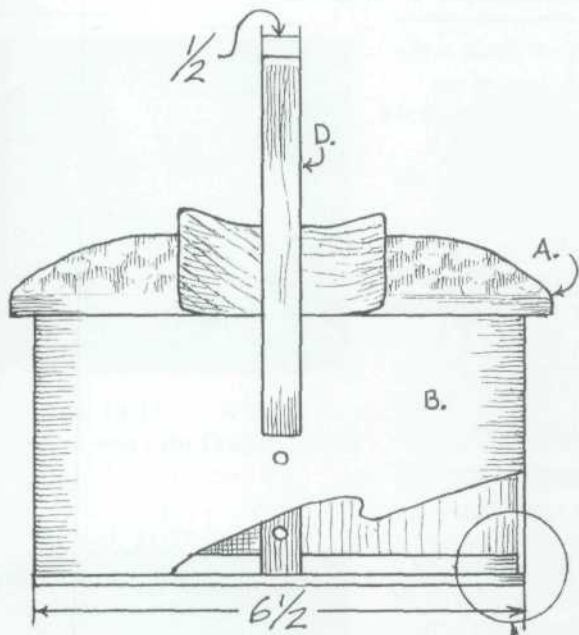

SIDE VIEW

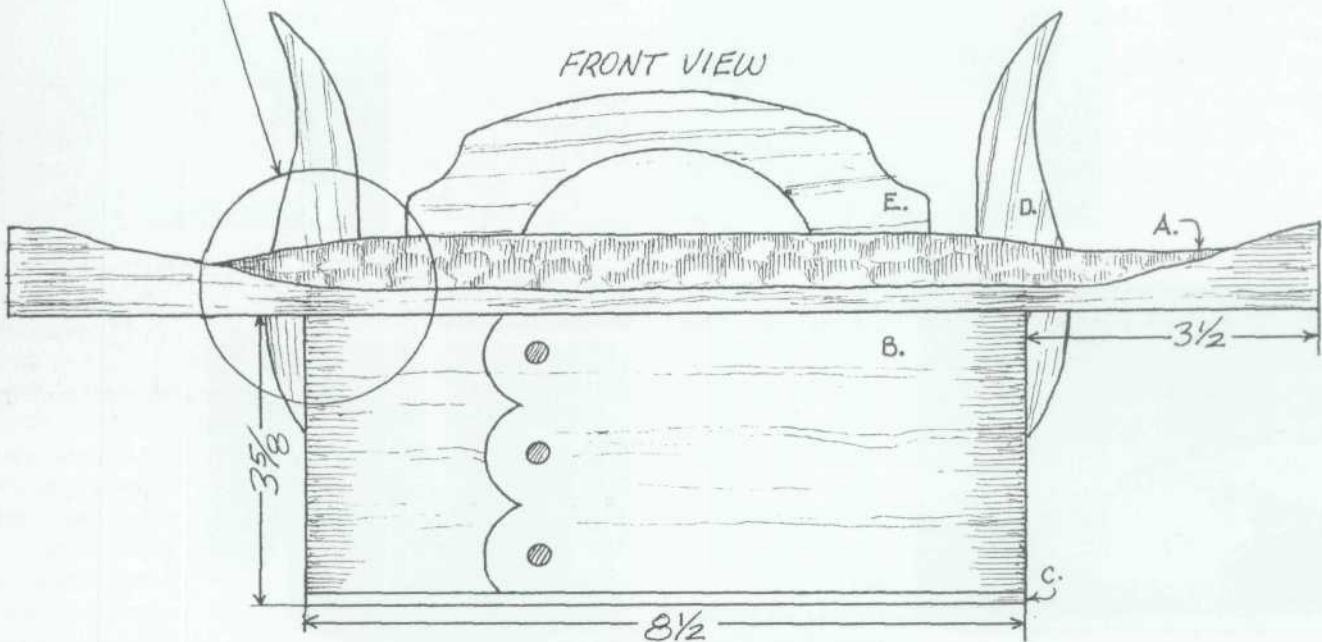
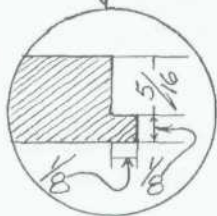
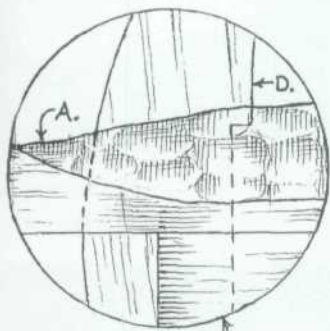
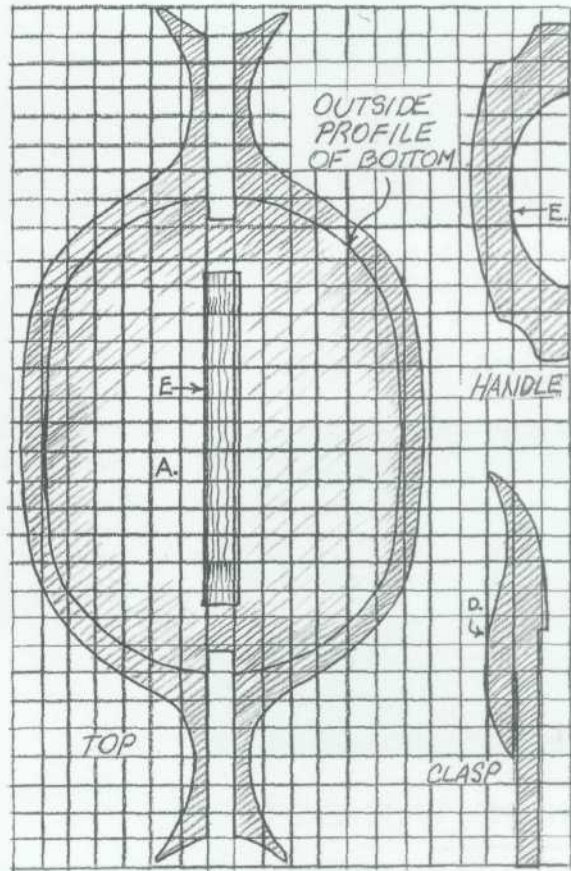

FRONT VIEW



This close up of the box side reveals peacock feather inlay in the holes, a very unique design element.

BENDING FORM

1 A block at the base of the bending form allows a vise to hold it. After wrapping the soaked, resawn stock around the form, clamp the caul to the form to hold it in place. Cut an opening in the top of the form for the clamp head.

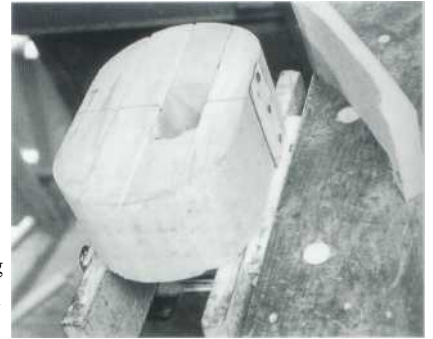

MAKING THE LID

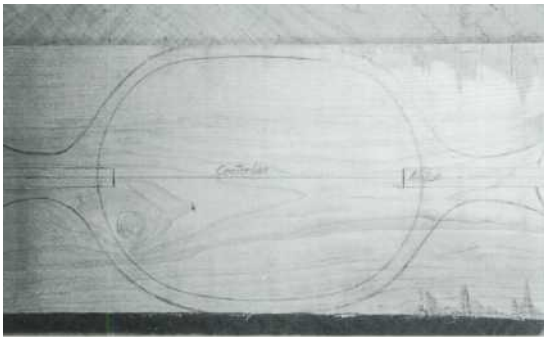

1 The layout of the lid is shown. Careful planning at this stage will ensure a lid that snaps cleanly into place.

2 If the surface of the lid is to be shaped, flat surfaces must be left for the base of the handle.

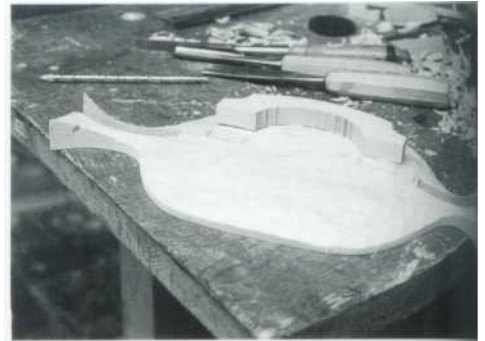

MAKING THE BOTTOM

1 Define the bottom of the rabbet that will receive the sidewalls by a shallow saw cut made all around the bottom.



2 Cut the rabbet with a chisel. Here, the chisel is cutting across end grain. After cutting another $\frac{3}{4}$ " of the rabbet, reverse the bottom in the vise in order to cut back to that point from the other side.



3 The various parts have been cut and fit and are ready for assembly. Notice the widened section of the rabbet which will receive the lapped section of the sidewalls. Notice, too, the notches for the bottoms of the clasps.

PEGS

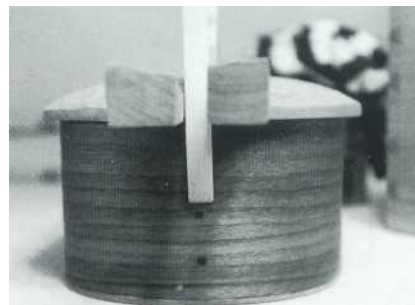

1 This shows the ends of two pegs driven through the sidewall into the clasp. Below, to the left, is one of the pegs holding the bottom and sidewall together. Drill a hole before inserting these pegs.