

# 137 WADDLING DUCK



Here's a toy that's sure to fascinate children: a duck that waddles across tabletops. It's powered by a  $\frac{5}{8}$ " steel hex nut that acts as a drive weight. Just hang the hex nut over the edge of a table and give the duck a nudge sideways; it will rock from side to side and walk toward the edge of the table.

1. Make full-size templates for the body (A) and legs (B) using the patterns provided. Cut out the shapes and rout or sand all edges.
2. Drill a  $\frac{1}{4}$ "-diameter eye hole and a  $\frac{1}{4}$ "-diameter hole to accommodate the leg pivot (C) in the body where indicated.

3. After cutting the leg pivot to size, drill a  $\frac{3}{32}$ "-diameter hole  $\frac{3}{16}$ " in from each end to accept the drawstrings.

4. Glue the leg pivot in place in the body.

5. Drill a  $\frac{9}{32}$ "-diameter hole in each leg where indicated to accept the leg pivot.

6. Sand the bottom edge of each leg so that it angles  $10^\circ$  up toward the outside.

7. Slide two flat washers and one leg onto each side of the leg pivot.

8. Tie a drawstring to each end of the leg pivot, and tie the free ends of both drawstrings to the hex nut.

9. Finish as desired, and the duck will be ready to waddle.

## LIST OF MATERIALS

(finished dimensions in inches)

<b>A</b>	Body	$3/4 \times 5 \times 8-1/2$
<b>B</b>	Legs (2)	$1-1/8 \times 4-3/4 \times 5$
<b>C</b>	Leg pivot	$1/4$ dia. $\times$ 4
	Flat washers (4)	
	Drawstring	#18 nylon cord
	Steel hex nut	$5/8$
	Wood glue	

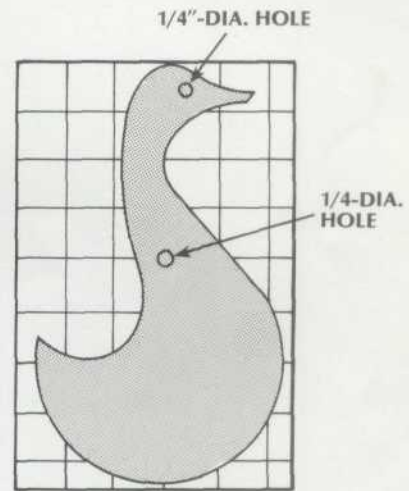
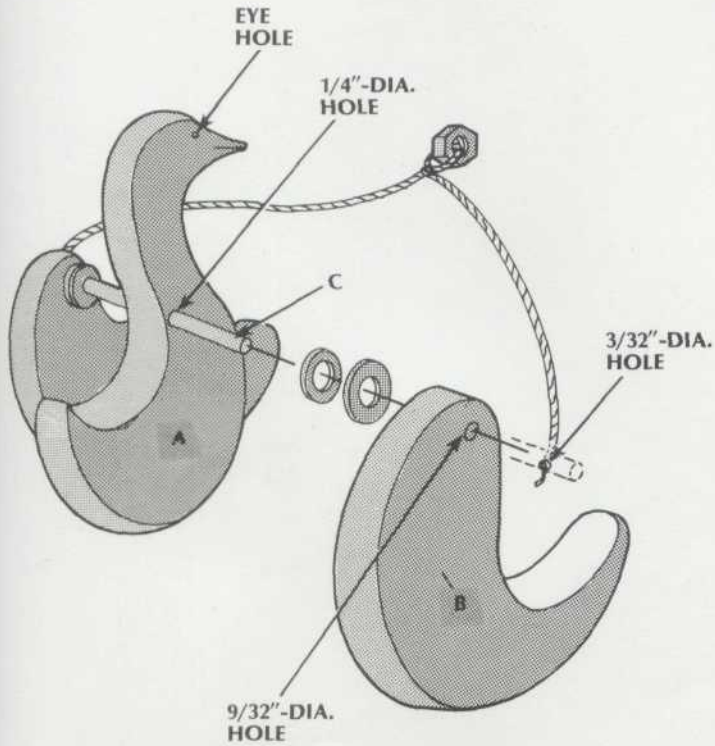

BODY CUTTING  
DETAIL

ONE SQUARE = 1"

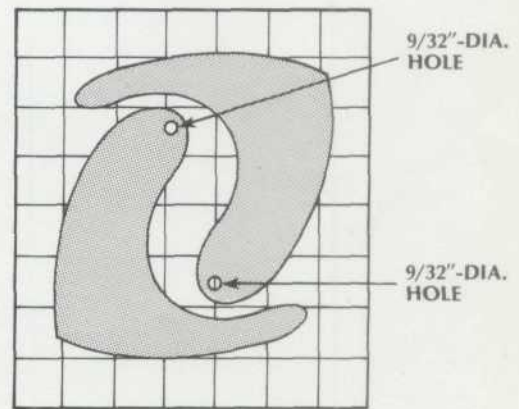

LEG CUTTING  
DETAIL