

EARTH MOVER

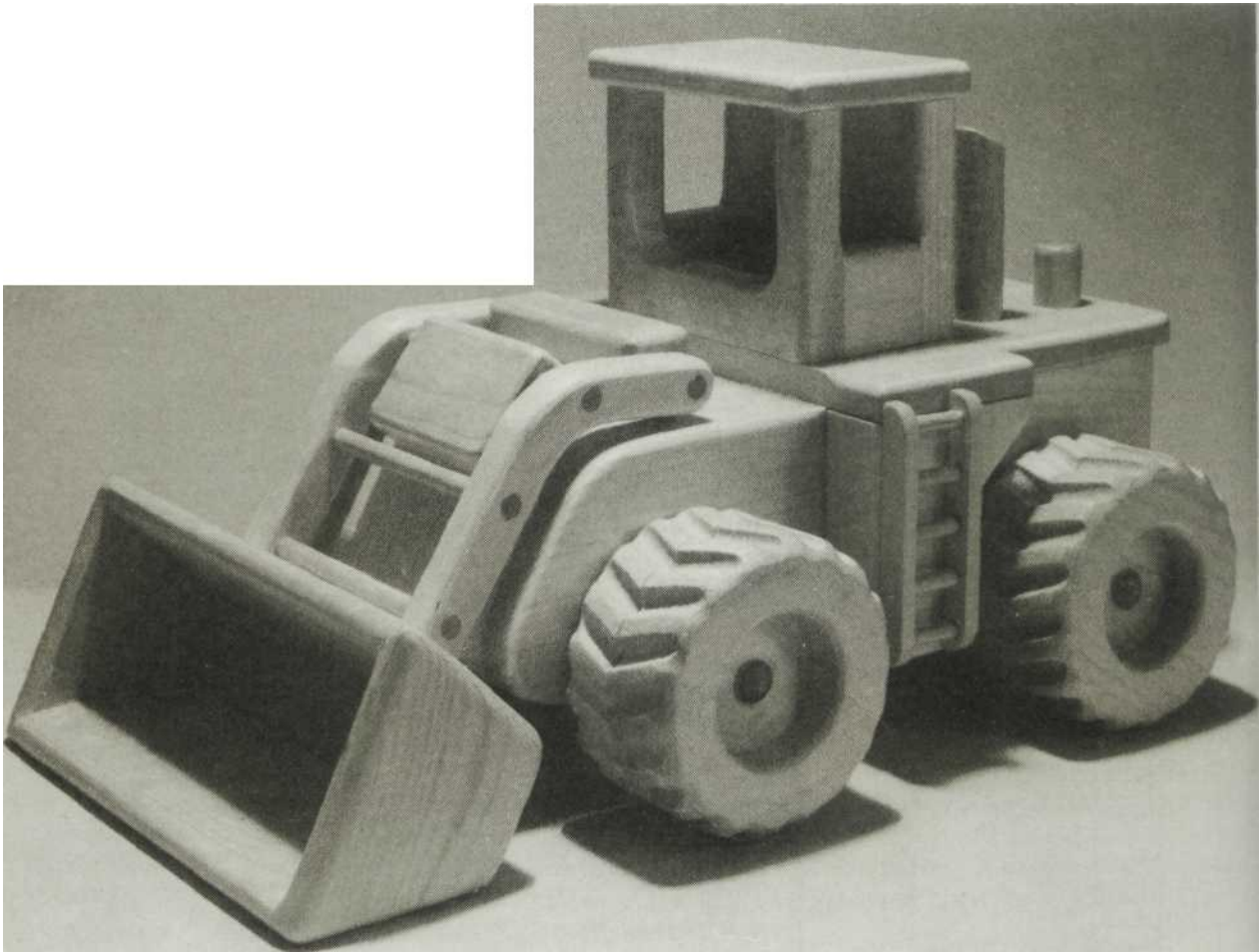

This earth mover features a moveable shovel that stops in different positions. This project should successfully accommodate most of your child's heavy earth moving needs for quite sometime. It is pictured here built in clear pine but it can be built in a wide variety of woods. Soft maple would be an excellent alternate choice.

Begin construction with the body. Rip an 18" length of 3/4" stock 4-1/2" wide then set the saw for a 30 degree bevel. Make a crosscut to produce the mitered ends. Cut from the remainder then make a series of 1/8" deep kerf cuts spaced 1/8" apart to detail the radiator grille.

Cut the side pieces to size then bore the axle holes before assembly. Use a belt sander or hand plane (or both) to form the front end curves.

Cut the cab and remaining body parts to size then use the router with a 5/32" corner rounding bit to ease all sharp corners before completing the body assembly.

Construct the bucket and bucket arm assembly. Mark the location of the arm ends and use a chisel to cut the 1/4" deep mortises to receive them. If you have a brad point or Forstner bit that bores a flat bottomed hole, use it first then square the corners with the chisel. The bucket pivot is nailed and glued to the body after the entire bucket assembly has been completed.

The fat wheels are made up by joining two discs of 1-1/8" stock after angled holes are bored to form the knobby treads. The simple jig used to

bore the holes features a hardwood guide block which has two holes drilled at 20 degree angles in **opposite** directions. Note that these holes must align with the pivot hole so they are bored from the bottom of the block before the jig is assembled.

The jig may be used with a portable drill or on a drill press. If using a drill press tilt the table or prop the jig so the bit enters the angled guide holes squarely. Bore the holes in discs #1 & #2 as indicated. To save layout time make photocopies of the wheel diagram and attach to each disc with rubber cement.

Use a 2" dia. Forstner bit to bore the recess in the outer disc, Part 1, then Counterbore for the plug and axle. Saw the discs to final size after the angled holes are bored to reveal the treads. Use the router to round over the corners. Sand then glue the wheels to the axles in place on the body.

Finish with several thin coats of shellac or two coats of polyurethane finish.

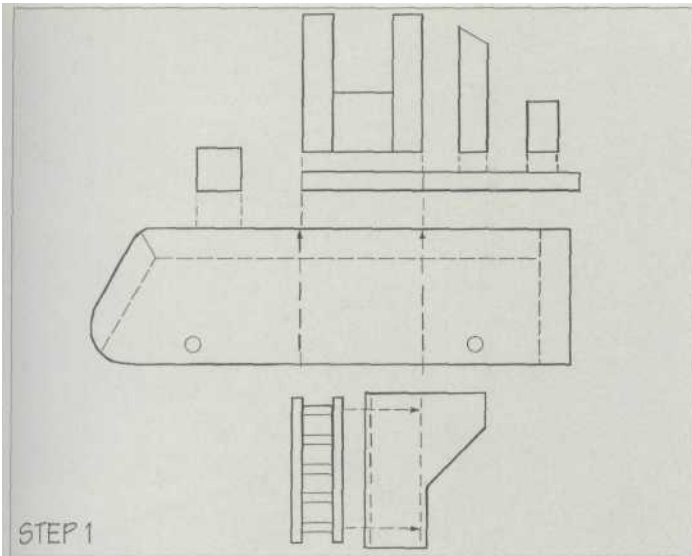

STEP 1

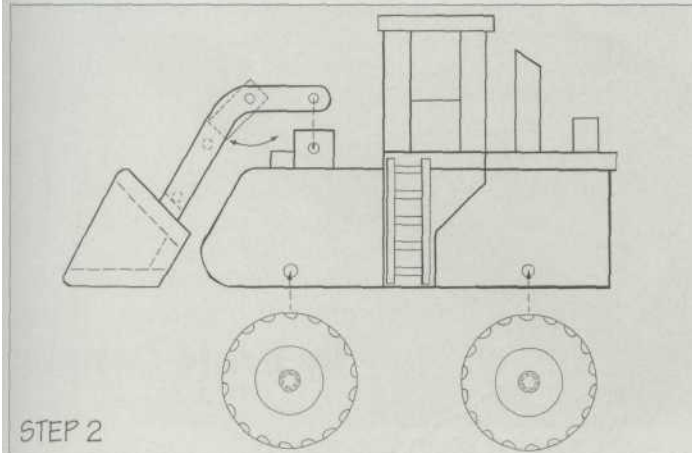

STEP 2

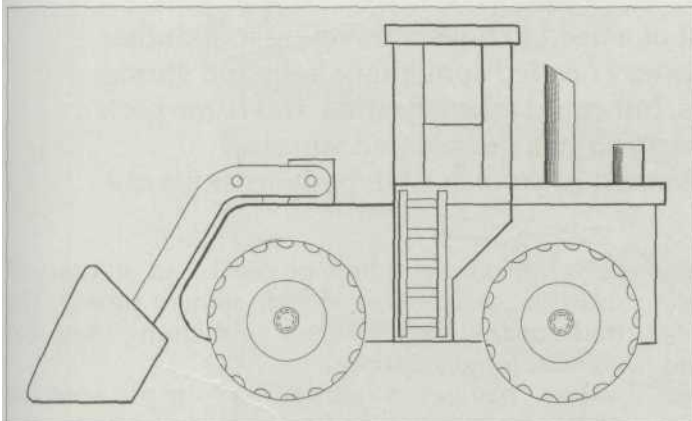

STEP 3 COMPLETED PIECE

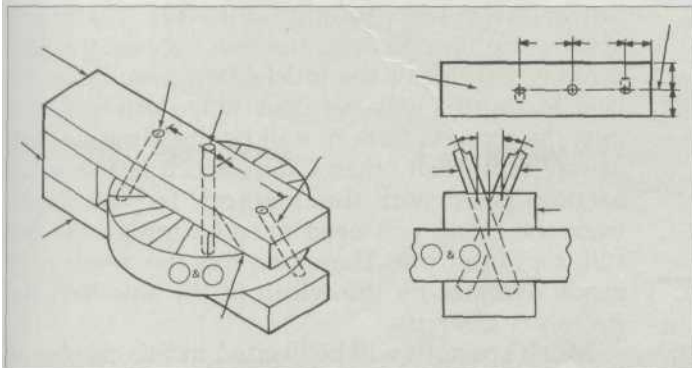

JIG FOR CREATING TIRE TREADS

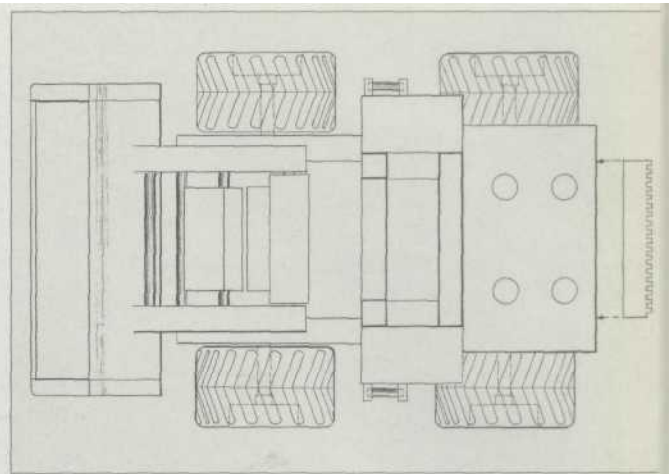

PLAN VIEW OF COMPLETED PIECE

BRUT EARTH MOVER MATERIAL LIST

QTY. DESCRIPTION

4	1-1/8" x 5" dia.	(outer wheel)
4	1-1/8" x 5" dia.	(inner wheel)
2	3/8" dia. x 8-1/2" dowel	(axle)
4	5/8" dia. wood buttons	(hub cap)
1	3/4" x 3-5/16" x 4-1/2"	(body front)
1	3/4" x 4-1/2" x 10"	(body top)
1	3/4" x 3-1/2" x 4-1/2"	(radiator)
2	3/4" x 3-1/2" x 12"	(body side)
2	1-1/8" x 3" x 3-1/2"	(body)
1	1/2" x 3" x 3-1/2"	(cab deck)
1	1/2" x 3-7/8" x 6-1/2"	(engine hood)
1	3/4" x 3-1/2" x 5"	(cab front)
1	3/4" x 3-1/2" x 5"	(cab rear)
2	3/4" x 1-1/2" x 1-1/2"	(cab side)
1	1/2" x 3-3/8" x 5-1/4"	(cab roof)
2	3/4" dia. x 3-1/2" dowel	(exhaust)
2	3/4" dia. x 1-1/2" dowel	(exhaust)
2	1/2" x 2-3/4" x 4"	(bucket end)
1	1/2" x 3" x 8"	(bucket rear)
1	1/2" x 1-1/4" x 8"	(bucket bottom)
1	1/2" x 3-1/2" x 8"	(bucket front)
2	3/4" x 2-1/4" x 6-1/4"	(bucket arm)
1	3/4" x 1-3/4" x 3"	(bucket lift)
1	1/2" x 5/8" x 3"	(bucket stop)
1	1-1/8" x 1-1/8" x 3-3/4"	(bucket pivot)
4	5/16" dia. x 5-3/8" dowel	(arm support)
4	1/4" x 1/2" x 3-3/4"	(ladder rail)
10	1/4" dia. x 1" dowel	(ladder rung)
4	7/16" I.D. x 1" O.D.	(flat washer)