



Wow! I Made It.com

## Lanai Dining Table

*We love outdoor cooking and dining with friends and family, but we ran out of room at our poolside table. So we built a new one! Now we have ample space to accommodate the food off the grill--and lots of neighbors, too! The tile top allows you to coordinate the table color with the rest of your outdoor furnishings.*



### **Materials**

- 10 linear feet of 4 x 4 pine
- 24 linear feet of 2 x 4 pine
- 14 linear feet of 1 x 2 pine
- 20 linear feet of 1 x 8 pine
- 1 piece of 3/8"-thick exterior plywood, measuring 52" x 28"
- 4 wooden finials\*
- Tile to cover an area 52" x 28"\*
- Tile grout
- Tile mastic
- Tile sealer

## **Hardware**

- 125 2-1/2" wood screws
- 50 1-1/4" wood screws

## **\*Notes on Materials**

The wooden finials which we used for the table "feet" are actually designed to be used on a fence post. They can be purchased most building supply stores, and have a large screw already attached in the center. The ones we used are 3 inches high. You can substitute any exterior-rated finial you like, but if it is higher than 3 inches, be sure to adjust the length of your legs accordingly, or your completed table will not be the correct height.

When choosing tile for this table, consider that you must cover an area measuring 52 x 28 inches. If the tile you choose will not fit into these dimensions evenly, you can either alter the dimensions of the table or –use our much easier solution—simply cut the tiles into interesting shapes.

To install the tile, you need a plain, metal trowel for spreading the mastic and a rubber-surfaced trowel for applying the grout. If you need to trim the tile to fit the table dimensions or want to cut them into pieces for a mosaic effect as we did with our table, you also need a tile cutter.

## **Cutting List**

Code	Description	Qty.	Materials	Dimensions
A	Leg	4	4 x 4 pine	26" long
B	Long Side	2	2 x 4 pine	55" long
C	Short Sides	2	2 x 4 pine	31" long
D	Center Support	3	2 x 4 pine	28" long
E	Short Inner Support	8	1 x 2 pine	11-7/8" long
F	Long Inner Support	2	1 x 2 pine	26-1/2" long
G	Long Trim	2	1 x 8 pine	66-1/2" long
H	Short Trim	2	1 x 8 pine	42-1/2" long
I	Top	1	3/8"-thick plywood	52" x 28"

## **Making the Legs**

1. Cut four legs (A) from 4 x 4 pine, each measuring 26 inches long.
2. In order to properly support the table, the legs must be dadoed. Refer to *Figure 1* to dado

the end of one leg (A). Note that the dado is 1-1/2 inches deep on each side, and 3-1/2 inches long.

3. Repeat Step 2 to dado the ends of the remaining three legs (A).

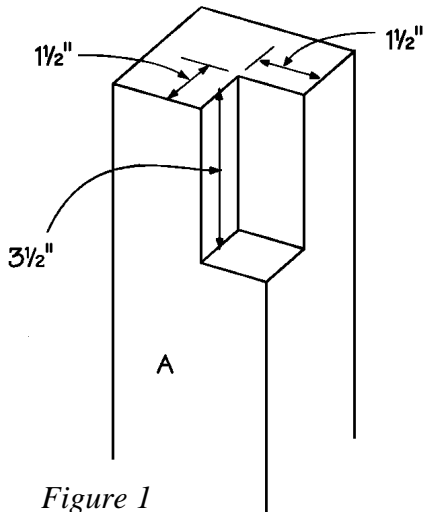

Figure 1

### **Adding the Table Sides**

1. Cut two long sides (B) from 2 x 4 pine, each measuring 55 inches long.
2. Miter each end of the long sides (B) at a 45-degree angle, as shown in *Figure 2*.
3. Note that the miters are mirror images of each other.
4. Cut two short sides (C) from 2 x 4 pine, each measuring 31 inches long.
5. Miter each end of the short sides (C) at a 45-degree angle, as you did for the long sides (B).

6. Place the long sides (B) parallel to each other on a level surface, with the miters facing in. Fit the short sides (C) between the long sides (B), matching miters on all four corners, as shown in *Figure 3*. Apply glue to the meeting surfaces of the miters, and screw through each mitered joint using a 2-1/2-inch long screw on each side.

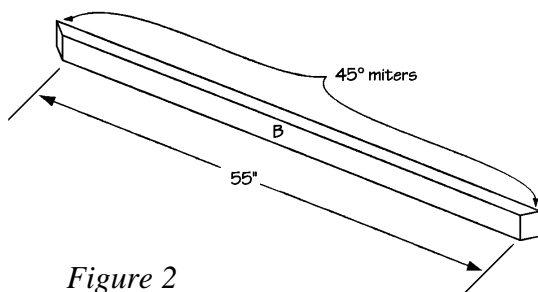

Figure 2

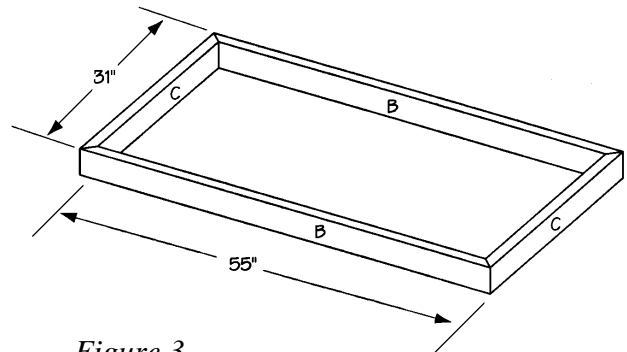

Figure 3

### **Attaching the Legs**

1. Turn one leg (A) dado-side down, and fit the dado over one corner of the side assembly, as

shown in *Figure 4*. Apply glue to the meeting surfaces, and screw through both the long side (B) and short side (C) into the leg (A). Use two 2-1/2-inch-long screws on each joint.

2. Repeat Step 1 three more times to attach the remaining three legs (A) to the three corners of the side assembly.
3. On the bottom of each leg, we attached a finial designed to top a fence post. Mark the center bottom of each of the legs (A), and screw in a finial.

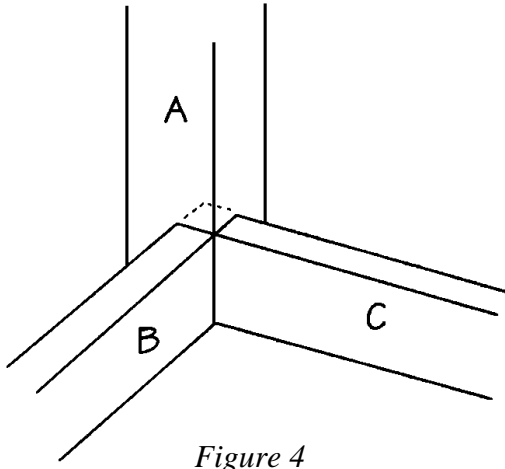
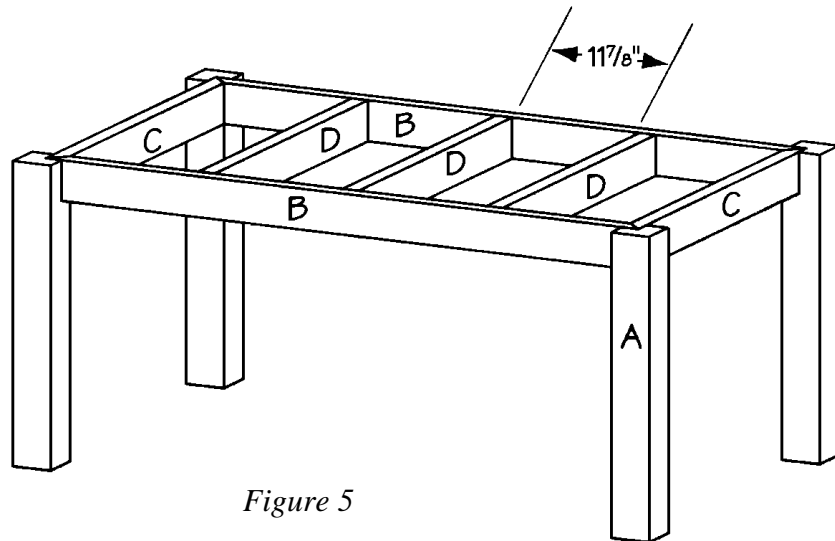

*Figure 4*

### ***Adding the Inner Supports***

1. Cut three center supports (D) from 2 x 4 pine, each measuring 28 inches long.
2. Fit the 3 center supports (D) between the two long sides (B), edge up, approximately 11-7/8 inches apart, as shown in *Figure 5*. Apply glue to the meeting surfaces and screw through the long sides (B) into the ends of the inner supports (D). Use two 2-1/2-inch-long screws on each joint.

3. Cut eight short inner supports (E) from 1 x 2 pine, each measuring 11-7/8 inches long.

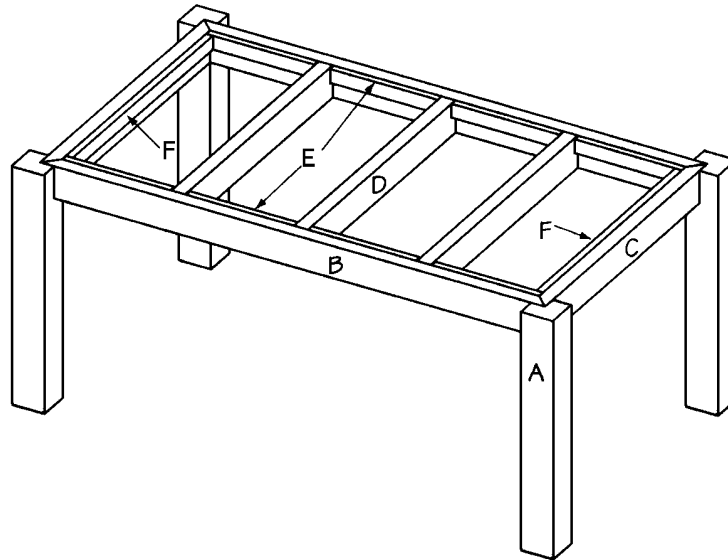

*Figure 5*

4. Fit one short inner support (E) flush with the top of the long side (B), between the short side (C) and the center support (D), as shown in *Figure 6*. Apply glue to the meeting surfaces, and screw through the short inner support (E) into the long side (B) using three 1-1/4-inch-

long screws. Repeat this process to attach the remaining seven short inner supports (E) to the long sides (B).

5. Cut two long inner supports (F) from 1 x 2 pine, each measuring 26-1/2 inches long.
6. Fit one long inner support (F) flush with the top of the short side (C), as shown in *Figure 6*. Apply glue to the meeting surfaces and use four or five 1-1/4-inch-long screws to attach each of these supports (F) to the short sides (C).



*Figure 6*

### ***Adding the Trim***

1. Cut two long trim pieces (G) from 1 x 8 pine, each measuring 66-1/2 inches long.
2. Miter both ends of each of the long trim pieces at opposing 45-degree angles, as shown in *Figure 7*.
3. Cut two short trim pieces (H) from 1 x 8 pine, each measuring 42-1/2 inches long.
4. Miter both ends of each of the short trim pieces (H) at opposing 45-degree angles, as shown in *Figure 7*.
5. Fit the long trim pieces (G) over the long sides (B), exactly matching the miters as shown in *Figure 7*. Apply glue to the tops of the long sides (B) and screw through the long trim pieces (G) into the long sides (B). Use 1-1/4"-long screws about every 4 inches.
6. Fit the short trim pieces (H) over the short sides (C), exactly matching the miters. Apply glue to the tops of the short sides (C) and to the miters. Screw through the short trim pieces (H) into the short sides (C) using 1-1/4" screws about every 4 inches. Finally screw at an angle through the ends of the short trim pieces (G), using one 2-1/2" long screw on each joint.

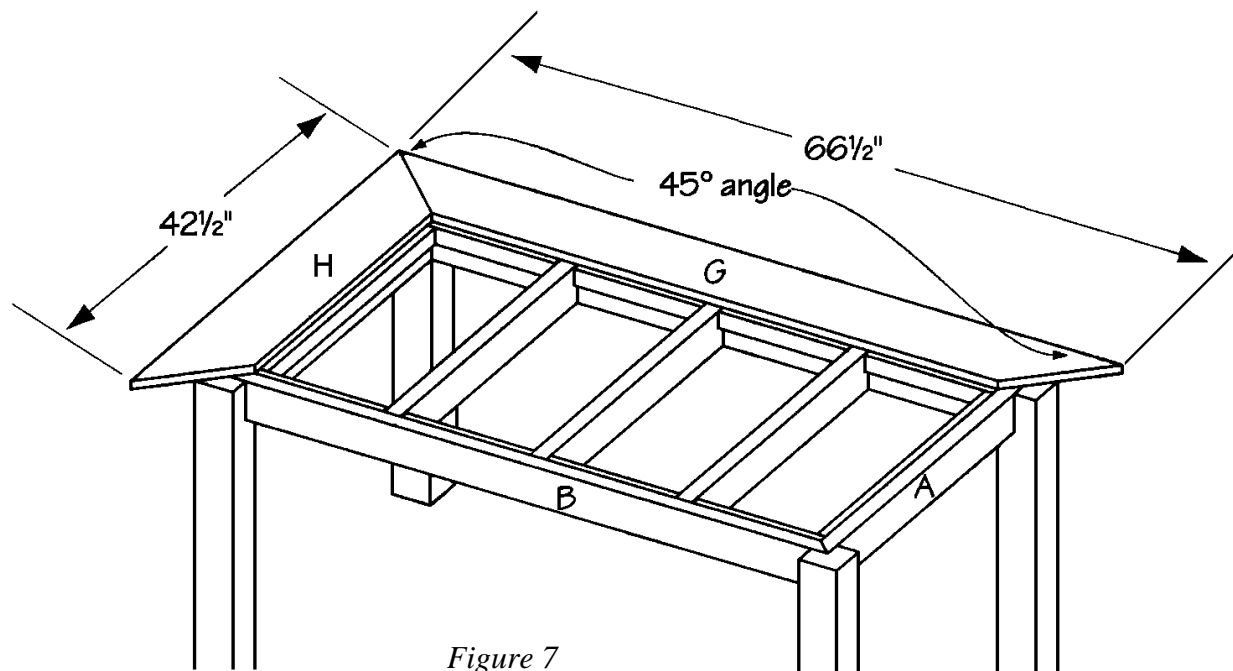

Figure 7

### ***Adding the Plywood Top***

1. Cut one top (I) from 3/8-inch-thick plywood, measuring 52" x 28".
2. Fit the top (I) in the center of the table over the supports. Notice that it will be 3/8-inch lower than the long and short trim pieces (G and H). This will allow enough depth for tile and mastic. Screw through the top (I) into all of the supports (D, E and F) using 1-1/4-inch-long screws spaced about every 5 inches.

### ***Adding the Tile***

1. Following the manufacturer's directions carefully spread an even coat of the tile mastic over the surface of the top (I) with a trowel.
2. Place the tiles on the mastic one at a time, making sure that they are positioned correctly. Do not slide them, or the mastic will be forced up on the sides of the tile. Let the mastic dry overnight.
3. Mix the tile grout according to the manufacturer's directions (or use pre-mixed grout).
4. Spread the grout over the tile using a rubber-surfaced trowel at an angle so that the grout is forced evenly into the spaces between the tiles.

5. Use a damp rag to wipe the excess off of the tiles and the joints. If you let it dry, the hardened grout will be very difficult to remove. The idea is to use as little water as possible when removing the excess so that you don't thin the grout that remains. Let the grout dry overnight.
6. Rinse the remaining film from the tile and wipe it with an old towel.
7. Apply grout sealer, following the manufacturer's directions.

### ***Finishing***

1. Fill all cracks, crevices, and screw holes with wood filler. Thoroughly sand all surfaces of the completed table.
2. We stained our table reddish brown to match our tile grout. You can stain yours a different color, or simply seal it with a waterproof sealer.

---

**Try other indoor and outdoor projects from**

!

