

132
TRESTLE COFFEE TABLE



Subtle shaping brings out the beauty of the birchwood in this coffee table with a trestle base. The top is made of five edge-glued boards. The narrow center board is darker than the others and is 1 5/6 inches wide; the other four boards measure between 4 inches and 5 1/2 inches each—enough to add up to the total width of 20 1/2 inches. Buy the lumber dressed to the thicknesses given below, and rip the boards using a straightedge to ensure that they are square. Order from 25% to 30% more than the amount specified, and spend time matching the boards in different ways before you begin

cutting those for the top to the final length. Measurements given in the chart for the feet (A), crosspieces (C), lower stretcher (D), and top (F) are for the boards before they are shaped. The step-by-step directions show how to cut tapers and shape curves. Be sure to cut all the joints before shaping the parts.

The top is screwed to the base with movable buttons, allowing the wood to contract and expand with changes in humidity while being held fast.

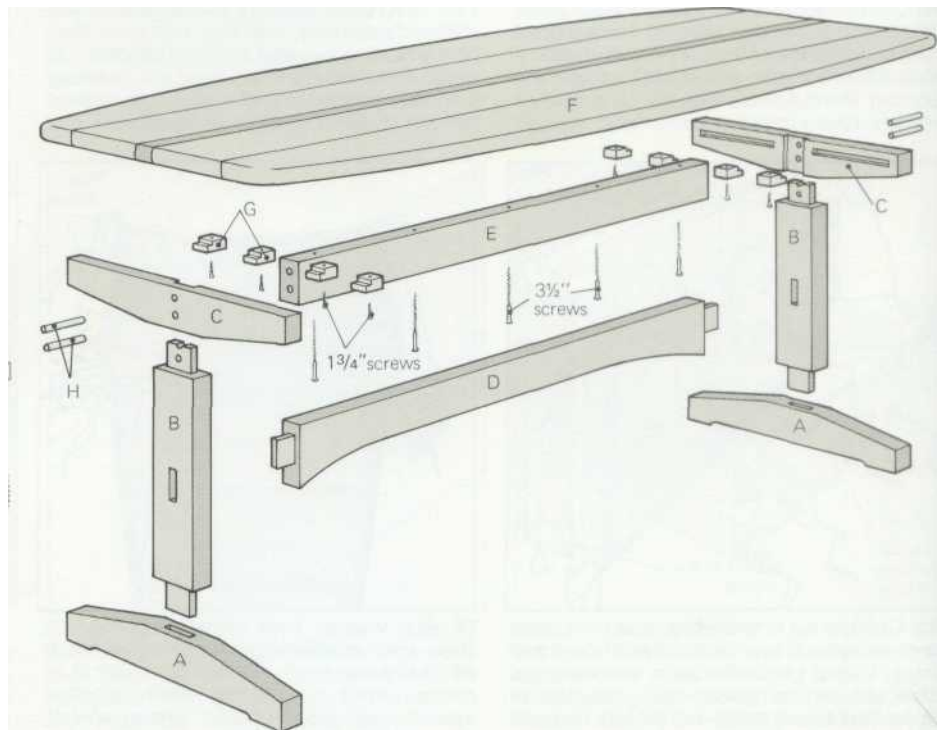

Parts list

Part	Name	Quantity	Thickness	Width	Length	Material
A	Foot	2	1 3/4"	2 3/4"	16"	Birch
B	Leg	2	1 1/4"	3"	15"	Birch
C	Crosspiece	2	1 1/4"	2 1/2"	14"	Birch
D	Lower stretcher	1	1 1/4"	3 7/8"	32 1/2"	Birch
E	Upper stretcher	1	1 3/8"	2 1/2"	29 7/8"	Birch
F	Top	1	1 1/4"	20 1/2"	50"	Birch
G	Button	8	1"	1 1/4"	7/8"	Birch
H	Dowel	4	1/2" dia.	—	2 3/4"	Dowel

Tools and materials: Table saw with combination blade, dado head, tenoning jig. Crosscut tray (optional). Band, saber, or coping saw. Dovetail saw. Router with 3/8" straight bit. Drill with 9/64", 13/64", 25/64" straight bits and 1/2" brad-point bit. Brace with 7/8" auger bit and depth gauge. Drill press and large hand screw (optional). Four 3' bar clamps, four 6" C-clamps. Smooth plane, fore or jack plane. Rasp, spokeshave or

Surform, cabinet scraper, 1" bevel-edged chisel, 3/8" mortise chisel. Framing square, combination square, steel tape rule, mortise gauge, knife. Wooden mallet, standard screwdriver, stubby screwdriver, hammer. Carpenter's glue, wax paper. Nos. 80, 120, and 220 sandpaper. Tung oil, 0000 steel wool, hard wax, cloths. Wood (see above). Eight 1 3/4" and five 3 1/2" No. 10 flathead wood screws.

Mortise-and-tenon joints

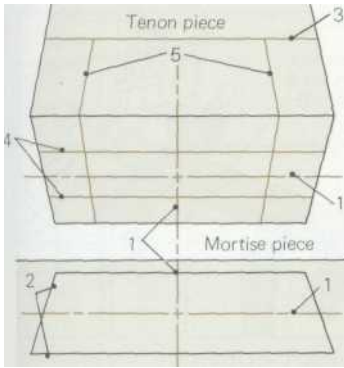

Cut and fit mortises and tenons prior to shaping parts. To lay out joints on legs (B), lower stretcher (D), feet (A), and crosspieces (C), mark in numbered order as at left.

1. Mark center lines.
2. Hold each piece that will have a tenon against its mortise piece (see captions at right for placement). Match center lines, and outline tenon pieces on mortise pieces.
3. Mark shoulder line of each tenon.
4. Use a mortise gauge to mark the thickness of each tenon on the end and sides of the tenon piece.
5. Mark the length of each tenon. Mark mortises in Steps 7 and 10.

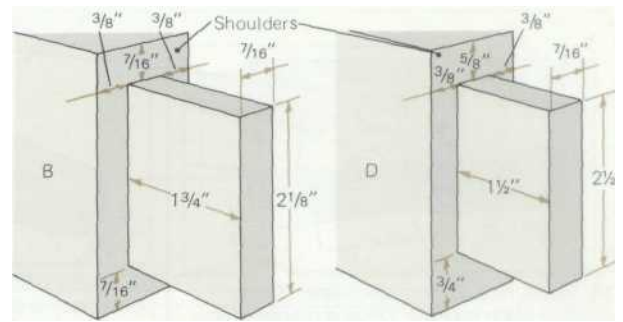

Cut this tenon on both ends of legs (B). Mortises are centered in the feet (A) and the crosspieces (C).

For tenons on lower stretcher (D), measure 4 in. from shoulders of top tenons on legs to top of D in Step 2.

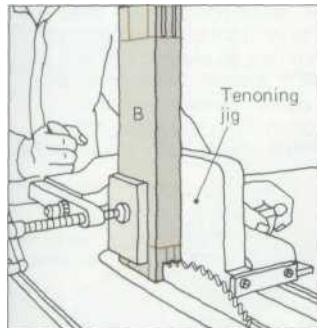

Cutting the tenons: 6. Use a tenoning jig on the table saw, and set the blade so that it cuts a scant 1/16 in. below the shoulder lines. On each tenon on both legs (B) cut one face; then reverse the work in the jig and cut the other face. Make all similar cuts before resetting the jig to make the next cut.

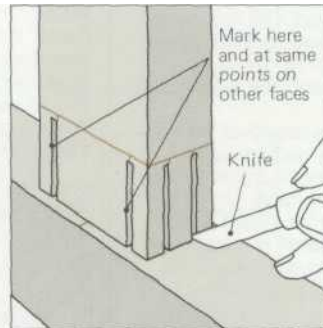

7. Before sawing the waste at the shoulders, center each tenon piece over its mortise piece. Hold a knife against the inner surface made by each saw cut and use it to mark the dimensions of each tenon on its mortise piece. These lines will later be extended (Step 10) to mark the outlines of the mortises.

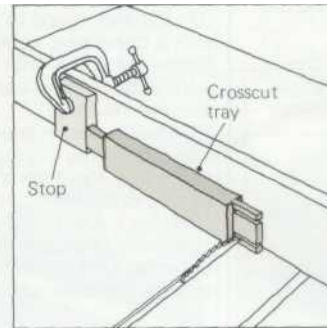

8. Clamp a scrap of wood to the crosscut tray as a stop; position it so that the saw will cut a scant 1/16 in. from the shoulder lines. Adjust the blade height, and cut off all the waste, turning each leg and holding it against the stop. If you do not have a crosscut tray, saw off the waste with a dovetail saw or other fine-tooth saw.

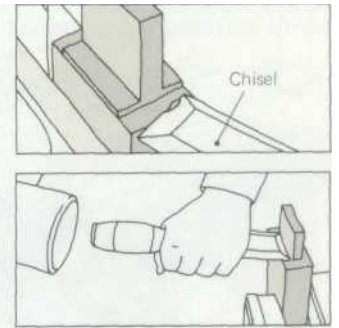

9. Trim each joint to the shoulder line with a narrow chisel, held with its beveled side up. Take paring cuts (do not use the mallet), working from one side, then the other. Trim along the long edge with your widest chisel and a wooden mallet. Follow the same procedure for the through tenons on the lower stretcher (D).

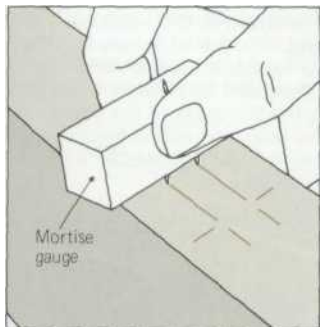

Marking and cutting mortises: 10. Set mortise gauge by marks made in Step 7; mark sides of each mortise. Using a combination square, mark the ends. Mark through mortises on each leg (B) the same way, and square markings around to opposite face. Have mortise gauge bear on same edge of each piece.

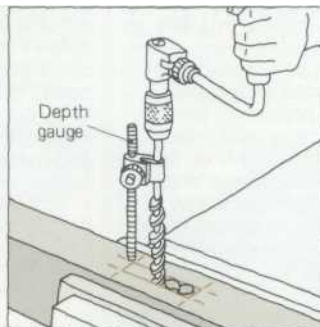

11. Using a brace and 3/8-in. auger bit, set depth gauge so that the bit will bore a scant amount deeper than each tenon's length. Drill on center line, making several holes. For each through mortise, bit should just pierce opposite surface. Turn work over and drill from that point or from center line.

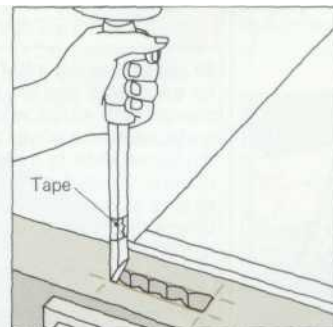

12. Mark the mortise depth on the mortise chisel by wrapping it with tape to match the length of each tenon. Use the chisel and a mallet to chop out the waste at the ends and in the bottom of the mortises. Work inward from both faces of the legs toward the center of the through mortises to clean their ends.

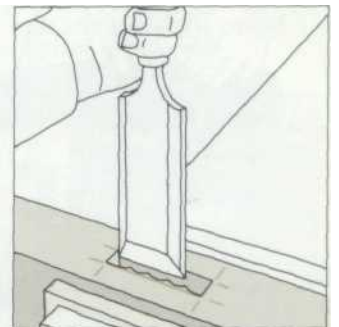

13. Use a wide chisel (but not a mallet) to take paring cuts that will smooth the sides of each mortise. Pare off 1/32 in. from both sides to allow the tenons an easy fit; keep trying the pieces so that the joints will not be loose. Work from both faces of each through mortise so that the edges will not splinter.

Scale drawings of trestle base parts

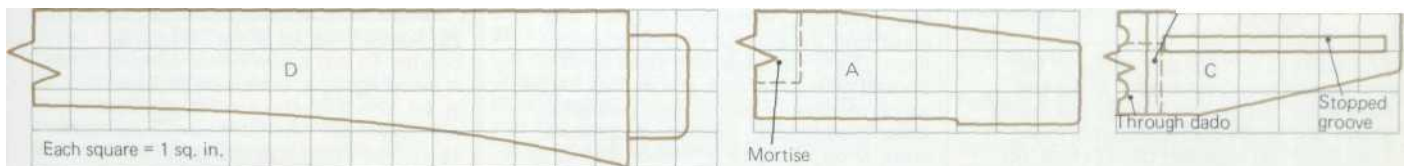

Each scale drawing represents half a member; the opposite half is identical

Trestle coffee table

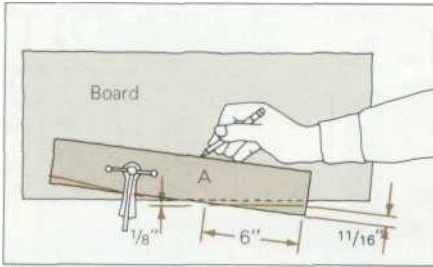

14. Measure 6 in. from each end on top edge of each foot (A). Draw a diagonal line from that point to form a triangle with an 11/16-in. base (see scale drawing, p.73). To construct a jig, clamp one foot to a squared board that is a third longer than the foot so that the taper line is parallel to the board's edge and overhangs it by 1/8 in. Outline the foot on the board, then unclamp it.

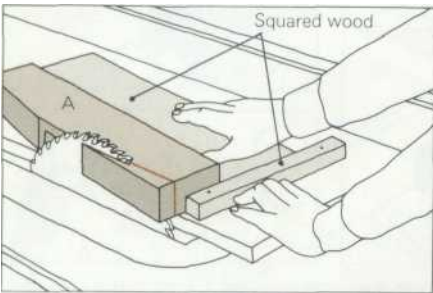

15. Nail two squared pieces of wood to the board along the side and back lines. Place each foot in this jig and saw along the taper, reverse each foot to saw the taper on the other end of the foot. Use the same jig for cutting each crosspiece (C); remove a triangle 1 in. at the base and 5 in. along the lower edge of each part C.

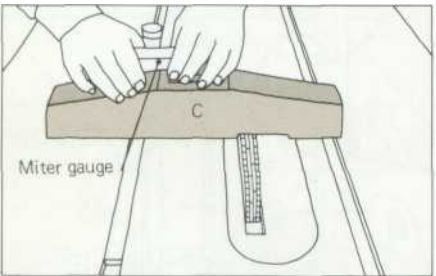

16. Shape the underside of each foot by setting the dado head at 5/32 in. high and making repeated crosscuts using the miter gauge. Or you can use a Surfform tool to remove and shape the wood.

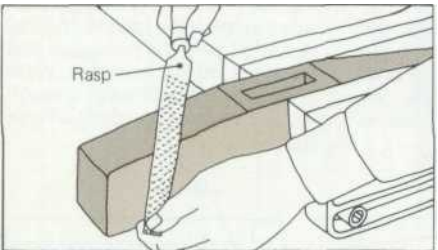

17. Round all corners and edges of feet and crosspieces with a rasp. Make one pass at 45°, and rasp off additional facets above and below until apparently round. Then finish the rounding off with Nos. 80, 120, and 220 sandpaper. Rasp and sand the underside of each foot.

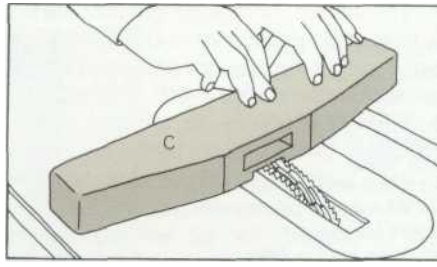

18. Use a dado head in the table saw, or a router and a straight bit, to cut a through dado in each crosspiece (C). Make it 3/16 in. deep and 13/8 in. wide. To cut the stopped grooves in the crosspieces, use a 3/8-in. straight bit in the router.

19. Enlarge the scale drawing on page 73 to make a template for the lower stretcher (D); transfer shape to wood. Cut the curve with a band saw, saber saw, or coping saw. Refine the shape with a rasp using its curved side. Rasp and sand the edges round as in Step 17.

20. Mark a center line the length of the upper stretcher (E) on its bottom surface. Along that line mark the positions of the five screws that will secure the table top to the stretcher—one in the center, one 1 1/2 in. from each end, and the other two halfway between. Drill shank holes with 13/64-in. bit, and Counterbore with 25/64-in. bit.

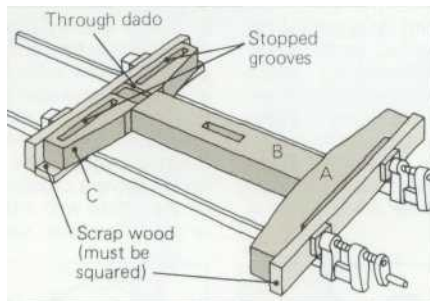

21. Glue one leg into foot and crosspiece for each end. Lay the pieces on two bar clamps with scrap wood protecting the surfaces and a scrap piece on one side of the crosspiece to make it lie evenly on the clamps. Spread glue on all surfaces of the tenons except the ends. Tighten clamps. Check that each side of the assembly is the same height; tighten clamp on longer side. Repeat for other end of base.

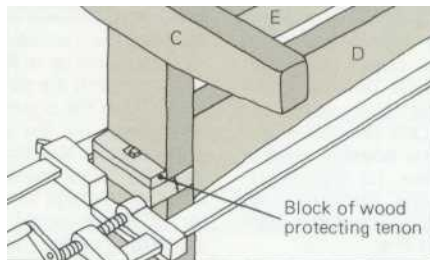

22. Cut two blocks of wood 3/4 in. x 3 in. x 3 in., and in each make a channel to accommodate the through tenons. Tape these over the through tenons to protect them. Dry-fit the base; trim joints for fit. Spread glue on tenon surfaces that will be inside mortises. Place clamps parallel to lower stretcher with handles at opposite ends. Drop the upper stretcher (E) into its dado, but glue it later. Check diagonally for squareness.

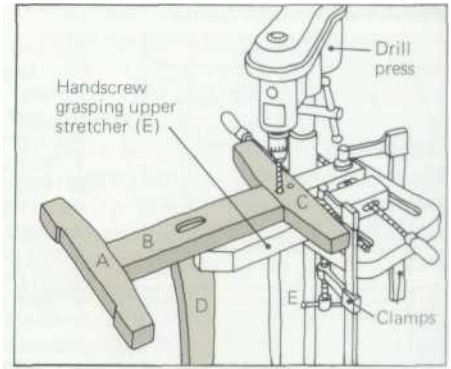

23. Clamp each leg assembly to a drill press table as shown, and drill holes for dowels (H) in each crosspiece with a 1/2-in. brad-point bit. Make holes 2 1/4 in. deep and center them 5/8 in. from top and bottom of crosspiece. Or use an electric drill with drill guide so hole is straight. Chamfer entering end of each dowel. Spread glue onto dowels and drive them into holes with a mallet. Saw ends almost flush and plane flat.

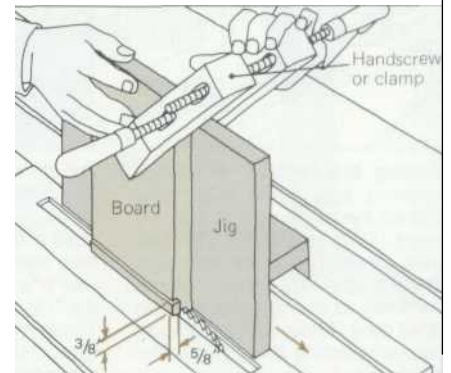

24. To make buttons (G), square and plane a board to 1 in. thick, 5-6 in. wide, and about 1 ft long. Use the table saw to cut a cross-grained rabbet at both ends of the board 5/8 in. deep and 3/8 in. wide. Make the 5/8-in. cut into the thickness of the board then stand the board on end in tenoning jig and make a 3/8-in. cut (Rabbet can also be cut with a router.)

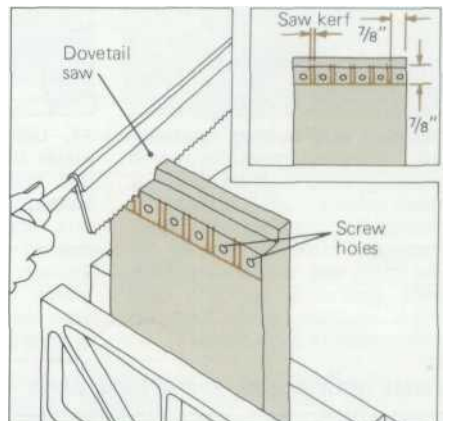

25. Scribe lines, as shown, on top of boards. To drill screw holes, clamp a scrap of wood tightly to underside and use a 13/64-in. bit. Drill through to scrap; Counterbore with 25/64-in. bit. Use table saw or dovetail saw to cut along right margin of each button to the 7/8-in. line. Saw along that line to separate buttons.

The table top

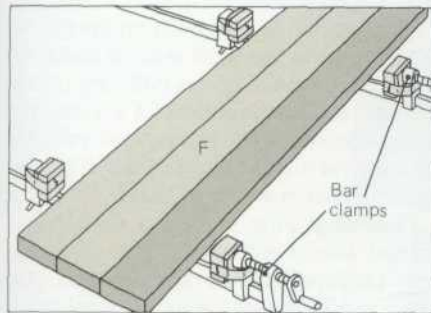
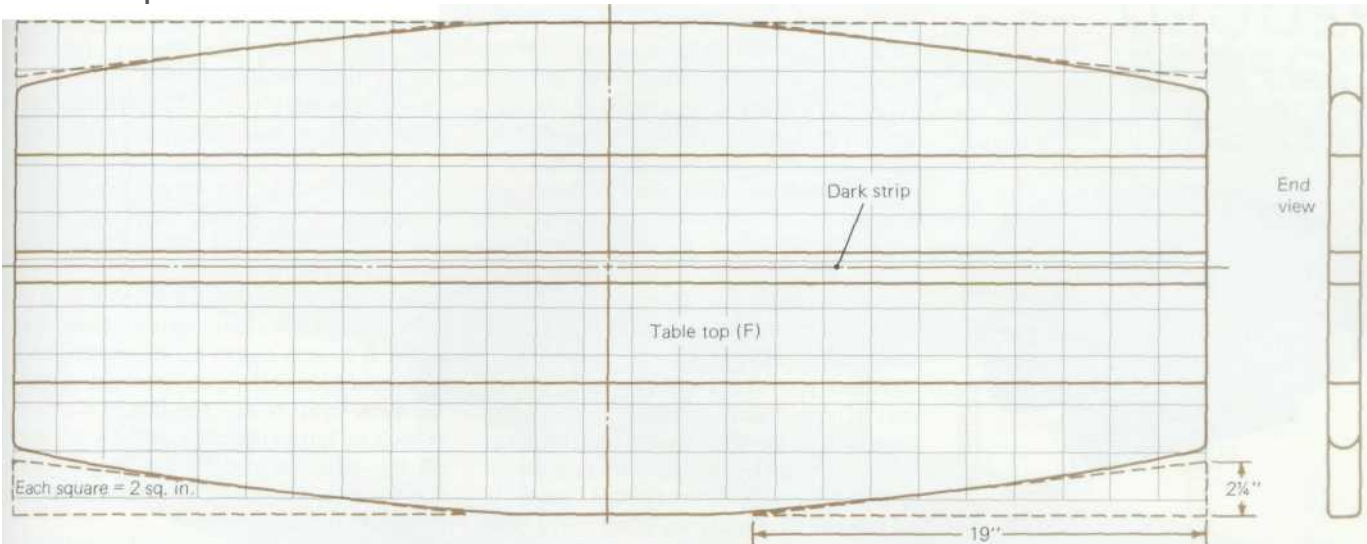

26. Check board for squareness; plane if necessary. Leave board from which you will cut center strip its full width until Step 28 to make planing easier. Tape scrap wood to laws of four bar clamps; place two clamps on work surface with wax paper across bars. Do a dry assembly to check procedure. Apply glue to one edge of dark center board and to two boards flanking that side. Join and rest boards on clamps.

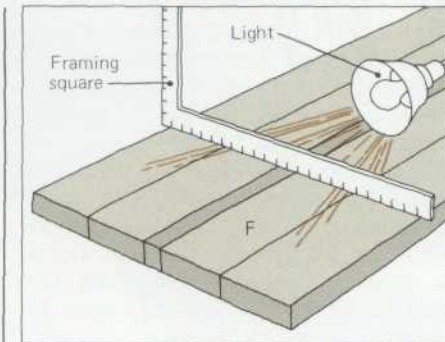

29. Scrape glue from surfaces. Beam a strong light across top, and move a framing square the length of the surface to check that it is level. Make pencil marks on high spots—where light does not show through. Plane down these high spots with a fore or jack plane, moving it in the same direction as the grain. Use a smooth plane to remove any remaining rough spots.

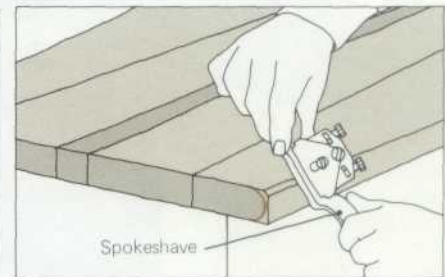

33. If remaining waste is wide enough, saw off with a dovetail saw, otherwise use a smooth plane. Enlarge the scale drawing at top right. Transfer the curve to the ends of the table top. Use a spokeshave or a Surform tool, followed by a rasp, to shape the curve. Continue rounding along the side edges, but gradually decrease the curve toward the center so that only the corners of the vertical surface are rounded.

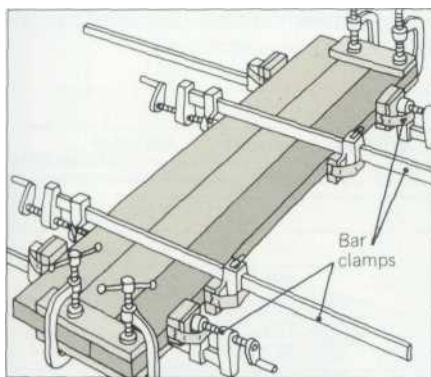

27. Place C-clamps directly over the glued edges at each end, protecting table top (F) with scraps of wood rubbed with paraffin. Tighten C-clamps to bring edges flush. Check with hand along the length of joint that all edges are flush; pound with wooden mallet to align them. Add bar clamps across top; tighten all bar clamps. Remove clamps after 2-4 hr, and saw center board to final width. Check for squareness and plane the sawed edge. Glue together the other two boards, as in Steps 26 and 27, then glue them to the first three boards.

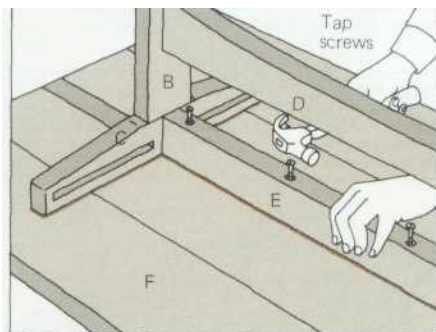

31. Center base on underside of table and draw its outline. Insert a 3 1/2-in. screw in each hole in the upper stretcher, then tap screws to mark their positions on underside of table. Drill pilot holes 1 in. deep using a 9/64-in. bit. (Wrap the bit with tape to serve as a depth gauge.)

32. Make a template for shaping the table top from scale drawing at top of page. Construct a jig similar to the one used to taper the feet and crosspieces (Steps 14 and 15). Saw off triangles that are 2 1/4 in. at the base and 19 in. along the table-top edge. Tape the cutoff pieces back in place while sawing triangles from the other end.

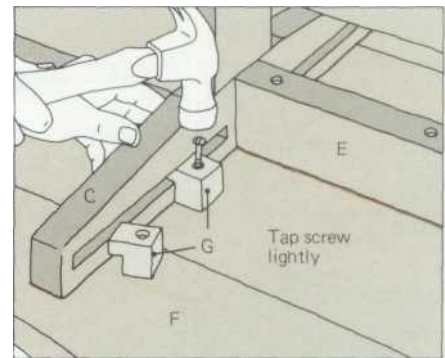

34. Place table top face down. Set base onto outline made in Step 31. Place buttons in grooves in each crosspiece. Insert a 1 3/4-in. screw in each hole; tap it to mark its position. Remove base and buttons. Drill pilot holes 3/4 in. deep with a 9/64-in. bit. Insert 3 1/2-in. screws in upper stretcher and tighten with a stubby screwdriver. Screw buttons in place. Sand table with Nos. 80, 120, and 220 sandpaper. Wet top with a cloth and let dry overnight. Resand with used No. 220 paper. Apply three or more coats of tung oil; rub each section hard until warm, then wipe dry immediately. Let sit overnight, and remove residue with 0000 steel wool. Wax if desired.