

## 1. **Securing Desk Tops**

Wood expands and contracts with temperature and humidity. It expands different amounts along-the-grain and across-the-grain. This effect can destroy a desk or table.

Below are four effective ways that you can use to attach a desk top to its frame. You can choose the best one for your project and to suit your skills, tools, climate, and materials.

## 2. **Understanding the Problem**

The different parts of a desk expand different amounts. The movements are small but they build up great forces. If you attach a desk top too firmly to its frame, then something has to give. Usually the top splits but sometimes the leg joints open up.

The wood expansion is greatest across-the-grain of edge glued planks. There is much less dimensional change in the with-the-grain direction and with plywood tops but there is still enough force to cause warping. There is always some expansion, so it pays to properly secure any top.

Despite this difficulty, you need to clamp the desk top to the frame so that each provides strength to the other, and so that the frame prevents the top from warping.

Properly addressing this problem can make the difference between a piece of furniture that last five years and one that last seventy-five years.

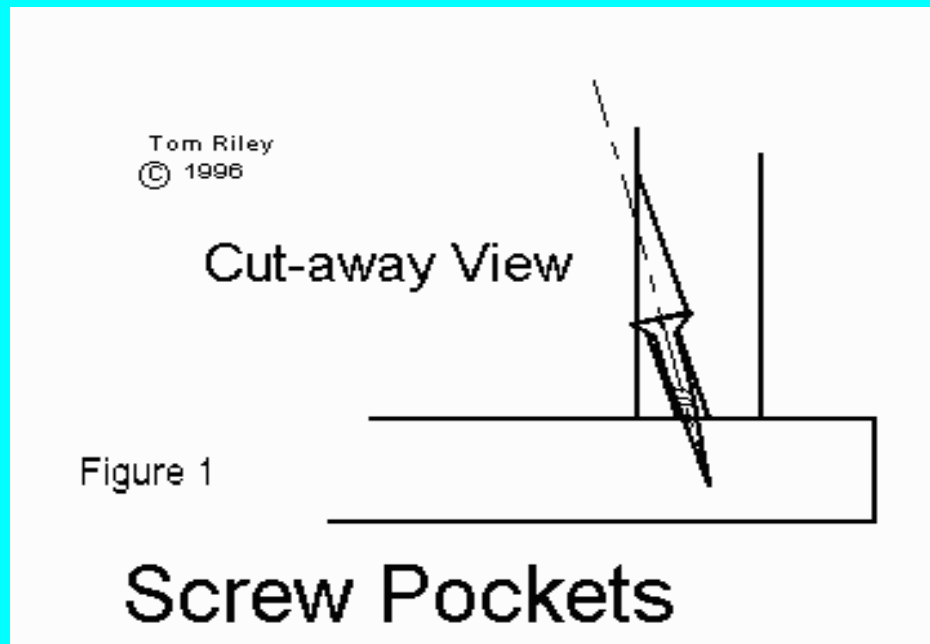

### 3. Screw Pockets

Screw pockets are simply small cut-away areas in the frame that are drilled for a screw (see Figure #1). They do not allow much movement but are suitable for only small shelves like the keyboard shelf.

There is a special tool just to drill screw pockets but it is expensive. It is available from many woodworkers' mail order houses.

You can cut the pockets with hand chisels but you must take care to get all the pockets even. There is the risk that the screws will break through the top if the pockets are not all even. Practice on scrap until you make them consistently right.

You can buy a drill that makes a hole with the ideal silhouette of a flat head screw. I use these drills for all the screws in all the desks. One type of these drills allows for deep countersinking. This type can be used to drill screw pockets.

First practice on scrap wood until you have the best height to start and a good angle. Make a measuring block the correct height and use it to make a deep hole with an awl to start the drill. Be careful not to drill too deeply.

Temporarily install each screw as you drill the holes. Then remove all the screws, and drill out the holes in the frame to be loose fits on the screw shafts. Also check, with the top removed, that the counter sinks are the right depth. Redrill the countersinks to just the right depth.

You can then reinstall the shelf but do not over tighten the screws. Remember you would rather have the screw slip a little than have the shelf crack.

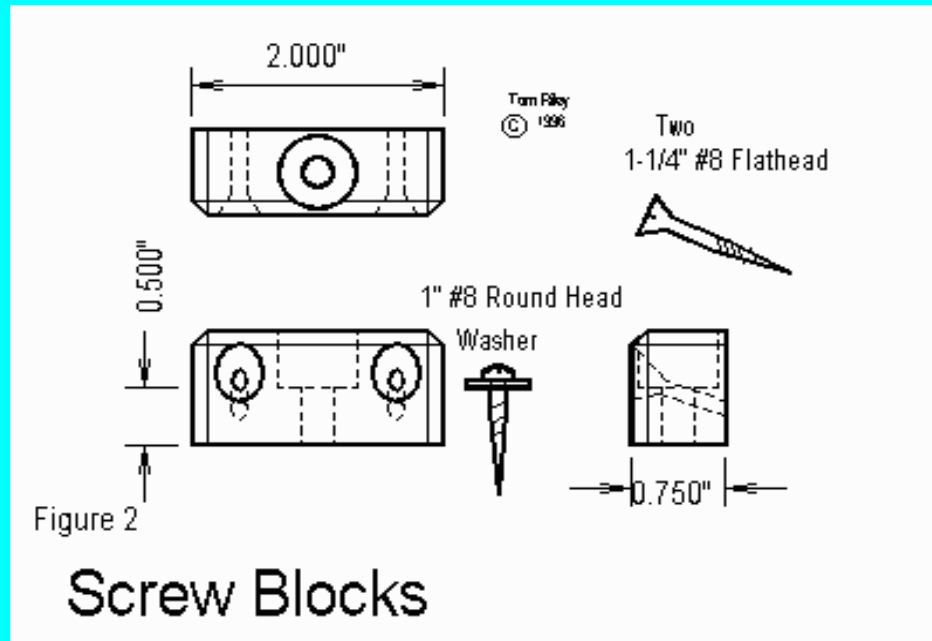

#### 4. Screw Blocks

Screw blocks are small pieces of scrap hardwood drilled out for wood screws (see Figure #2). You attach them solidly to the desk frame but less tightly to the top. To be sure the top can move, you oversize its screw holes and place a metal washer under the screw head.

The frame mounting screw holes are angled up so you can drive the screws in a tight place. If you still cannot get a driver in, simply glue and clamp the block without the screws.

Buy the round head screws (pan head screws will do) and washers before drilling the block. Then drill a hole that is large for the washer and deep enough to allow the screw to extend just the right depth into the top. A 5/8-inch hole for the large hole and a 1/4-inch hole for the screw body usually works.

Drill pilot holes for the screws but be very careful not to break through surfaces that will show on the finished piece. Don't over tighten the top screw.

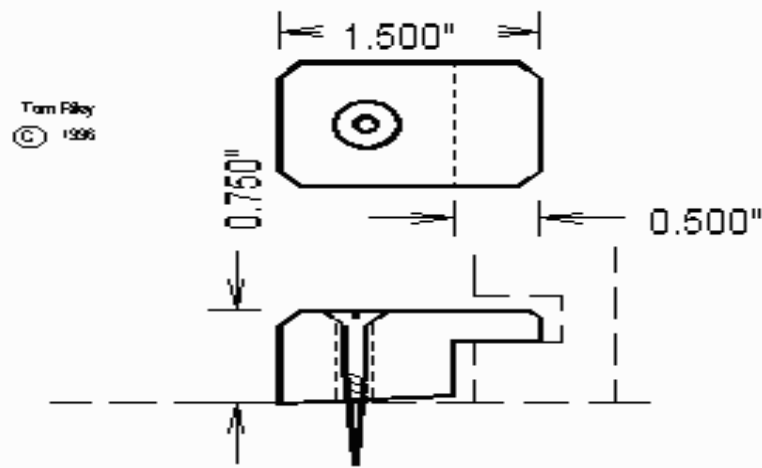

## Buttons

### 5. Buttons

Buttons are straight grained blocks of strong hardwood like maple (see Figure #3). They have one screw hole and lip that sticks out.

The button lip fits into a slot in the frame. This slot can be made with a router, with hand chisels, or with a biscuit slot cutter. The trick is to make small, flat shelf at exactly the right distance from the desk top.

Remove a little material from the lip end of the button's bottom and over size the screw shaft hole. This lets the button rock forward as the screw tightens. Rubbing the area on a sanding block is usually removes enough material.

Locate the buttons so that they do not quite touch the frame and drill a pilot hole. The top might expand and shift the button toward the frame, so you must leave a little room between the frame and the bottom.. Again do not over tighten the screw.

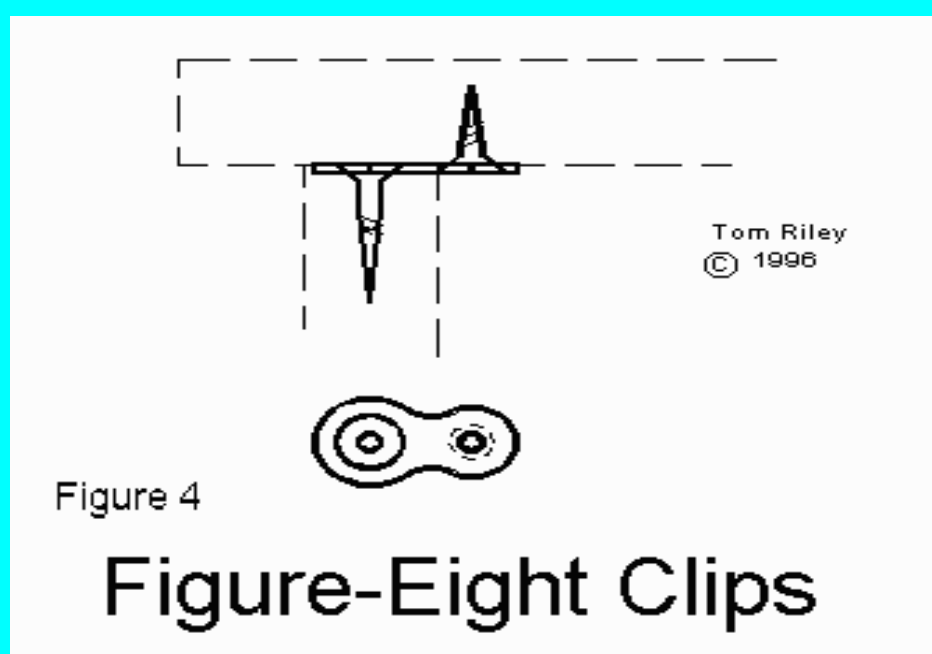

## 6. Figure-Eight Clips

Figure-Eight Clips are small pieces of metal hardware designed specifically for attaching table tops. They can be obtained from larger hardware stores and woodworking mail order houses. They fit into a shallow recess drilled in the frame and have one screw pointed down into the frame and another pointed up into the desk top.

They provide for only limited movement of the desk top. This may not be enough for wide, hardwood planked tops, specially in humid climates. It should be enough for narrow tops, plywood tops, and top made of stable woods like mahogany.

These clips are easy to install at any time. Simply drill a shallow recess the size of the larger part of the figure-eight in the top of the frame member. Carefully drill pilot holes for the screws in both directions.

The Figure-Eight Clips look nice enough to be seen on the outside of the finished piece.