

Barbecue Trolley

Many of those odd bits and pieces required at the outdoor barbecue can be delivered conveniently on this barbecue (or indoor tea) trolley. Basic design consists of two equal sized flat trays supported on corner posts. However we strongly advise that you decide first on the sort of wheel/axle system since width of trays should be made to fit closely between the wheels. With some changes in details the width of this barbecue trolley can be adjusted to suit your purchased wheel, axle, bracket units. As an alternative you could use a system of bolts and lock nuts, etc to fasten wheels to base tray or corner post as shown later.

| TOOLS YOU WILL NEED | MATERIALS YOU WILL NEED | |
|--|---|--|
| <ul style="list-style-type: none"> • Saws • Drill and bit, countersunk bit • Measuring tape/rule • Carpenter's square and pencil • Adjustable spanner • Wood chisel • Hammer • Screwdriver • Chisel | <p>Timber</p> <p>Note that this trolley is designed on the assumption that it will be generally protected from exposure to rain and dew. If this limit on exposure is accepted then standard door jamb lining can be used (e.g. from Pacific Maple, meranti, oregon, radiata pine, Tasmanian oak, etc.) and standard or interior quality particle board or plywood would be acceptable for bottom of trays. Corner of posts could be timber selected for appearance rather than for performance under weather exposed conditions.</p>  <ul style="list-style-type: none"> • 50 mm x 50 mm DAR 4 pieces 750 mm * (4 posts) • 100 x 38 mm door jamb lining (see diagram) 4 pieces 900 mm * (side rails) 4 pieces 600 mm * (end rails) • 100 x 25 mm DAR softwood | <p>Hardware</p> <ul style="list-style-type: none"> • 8/50 x 6 mm diameter round head wood screws (end rail to post). • 40 mm x 6 mm diameter round head wood screws (side rail to post, handle) • 100/50 x 2.8 mm bullet head nails. (bottom planks) • PVA wood adhesive • 2/150 mm diameter wheels/axles bracket units as |

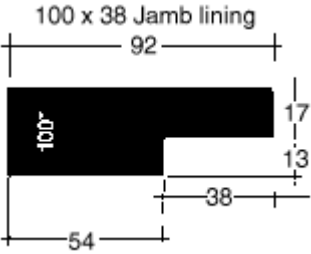
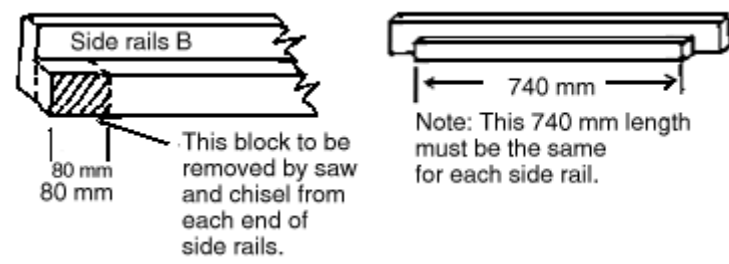

| | | |
|--|---|------------|
| | <p>16 pieces as bottom planks or use 19 mm particleboard or 12 mm plywood cut to fit frames.</p> <ul style="list-style-type: none"> • 75 x 25 mm DAR softwood • 1 piece 900 mm * (rail bracket) • 19 mm or 25 mm diameter dowel or • 1 piece 700 mm for handle/rail <p>* Discuss these length requirements with your supplier, who will supply standard lengths of timber from which these pieces can be cut.</p> | available. |
|--|---|------------|

Step by Step

Cut corner posts

From the pieces of 50 x 50 mm DAR timber cut four posts (P) each 750 mm long.

Cut end rails

From the pieces of door jamb cut four end rails (A) each of an exact length to suit the axle/wheel system.

Example: For an overall width of tray of 500 mm cut four end rails each 465 mm long

Mark out side rails

At each end of the four side rail pieces mark out as shown 80 mm from each end. Mark edges as guide for removal of excess material.

Saw and chisel out rail section

Saw and cut on marked line 80 mm from each end and chisel out excess materials to give four rails as indicated in diagram. Check the dimension shown as 740 mm in diagram. This measurement should be the same for each cut and trimmed rail.

Assemble tray frame

Projection approx 50 mm
Fit tray bottom to ledge.

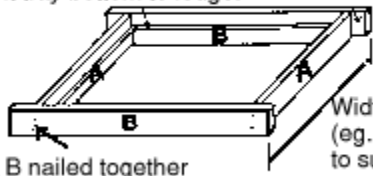

Width of tray
(eg. 500 mm)
to suit wheel
system.

using nails. Check
of trays and confirm
trays are the same
rails and adjust
necessary.

Cut bottom planks

Measure internal
as shown in previous
16 bottom planks to
cut particleboard or
fit in as tray bottom.

Screw and glue fix
side rails to post.

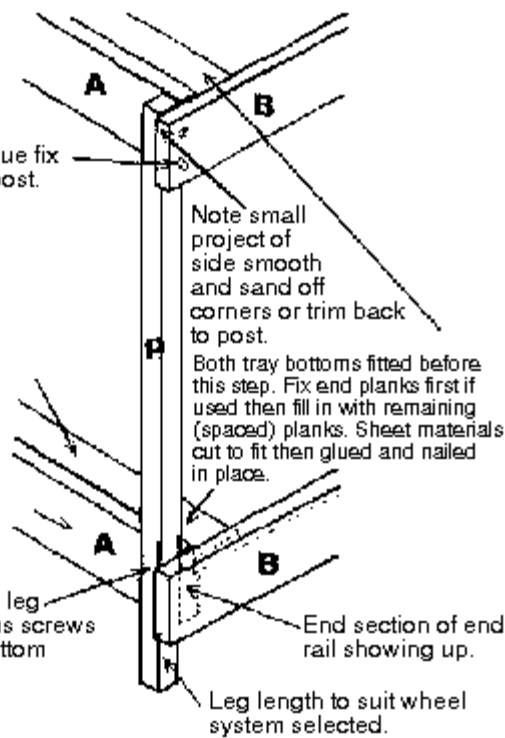

Note small
project of
side smooth
and sand off
corners or trim back
to post.

Both tray bottoms fitted before
this step. Fix end planks first if
used then fill in with remaining
(spaced) planks. Sheet materials
cut to fit then glued and nailed
in place.

Fit tray rails
together and
fix in position
squareness
that the two
size. Trim
where

End rails fix to leg
using glue plus screws
from under bottom
plank.

End section of end
rail showing up.

Leg length to suit wheel
system selected.

width of tray
diagram. Cut
this length or
plywood to

Square up trays

Fit a bottom into each tray and fix in place using glue and nails. Before final fixing square up tray and check that the two trays are of the same size.

Attach legs

Fix trays to the four legs as shown in diagram below using glue and screws. Note that the final length of each pair of legs will depend on wheel/axle bracket system used. However, in this initial assembly, the four posts are of equal length such that the overall height remains at 750 mm. The distance between trays may be varied depending on the wheel and axle system chosen.

Fix wheel system

Note: The assembly could stand on four legs until the wheels are attached to the front of the units, or the front 'legs' are removed first as appropriate for selected wheel assembly. Fit selected wheel/axle system. Cut off excess front legs as required.

Provide drainage holes

If sheet products (particleboard or plywood) are used in trays, provide drainage holes (9mm 3/8" diameter in each corner. Loose fitted plank bottom if used should give adequate drainage.

Smooth and rounding off

Using sanding disc, sander or hand sanding or planing, smooth and round off all accessible sharp corners and edges of the trays and posts. Punch all nails if desired and fill nail holes with putty/filler the same colour as timber.

HANDLE PATTERN

(Make 2) Round off edges corners before fitting.

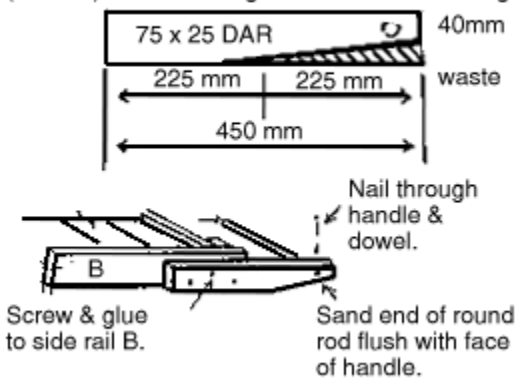

Note: The trays could have side rails projecting 5-10 mm beyond posts. These projections should be rounded off thoroughly, or trimmed off.

Cut, trim and fix handle

< From the piece of 75 x 25 mm DAR x 900 mm cut two handles each 450 mm long. Trim or shape as in diagram, smooth all corners and edges, then screw - and glue-fix to rear end of upper tray as in diagram.

Note: To make sure that handle fits flat to the rail you may need to chisel out small pieces of the handle where it comes into contact with the heads of screws into posts or use countersunk screws.

Cut to length and insert broom handle/dowel. Use glue in hole and drive in one 30 mm long nail through top edge of shaped timber piece into handle/dowel.

Apply finishes

Clear finish with three coats of satin clear polyurethane finish, or selected stains, or garden furniture finish or conventional paint finish. It is strongly recommended that the trolley receive a thorough coating of one of these finishes and that this coating be maintained adequately.

For weather exposed trolleys

If the trolley is to be exposed to weather for long periods, then be selective about materials. For timber components for example select 'durable' or moderately durable timbers such as western red cedar, jarrah, black butt etc. or preservative treated timber, OR pay particular attention to applying exterior finishes (and then maintenance) to low durability timbers. Fastenings (nails, bolts, etc.) should be non-corroding such as hot dipped or electroplated galvanised coatings.

Alternative wheel/axle systems

Dimension 'A' adjusted to suit your system
Check wheel clearance from tray side

