

80

DRILL PRESS TABLE



Schedule of Materials: Drill press table

No.	Let.	Item	Dimensions T W L	Material
1	A	Platform	3/4" x 20" x 29"	Plywood
1	B	Fence	1 1/2" x 2 3/4" x 30"	Hardwood
2	C	Fence base plates	3/4" x 3" x 9"	Plywood
4	D	Base plate braces	3/4" x 3" x 1 7/8"	Hardwood
2	E	Stops	3/4" x 2 1/2" x 2 1/2"	Hardwood
2	F	Hold-down plates	3/4" x 1 1/2" x 3"	Hardwood
1	G	Insert plate	3/8" x 4" x 4"	Plywood
2	Part #88F05.02 DeStaCo clamps — \$14.50 ea.			
6	Part #12K7901 24" T-slot track — \$4.95 ea.			
8	Part #00M5102 1 1/8" 3-wing knobs — \$6 for 10			
8	Part #05J2115 T-nuts — \$1.15 for 10			
All hardware available from Lee Valley 800-871-8158				

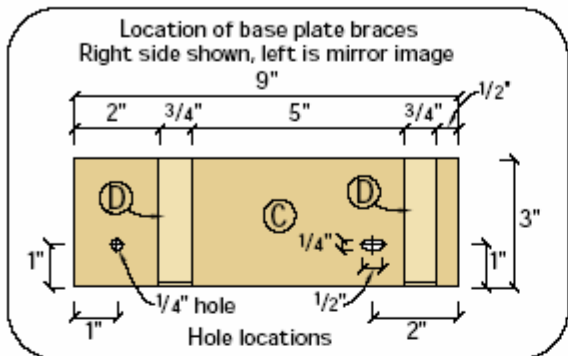

Plan detail of hole locations for base plate

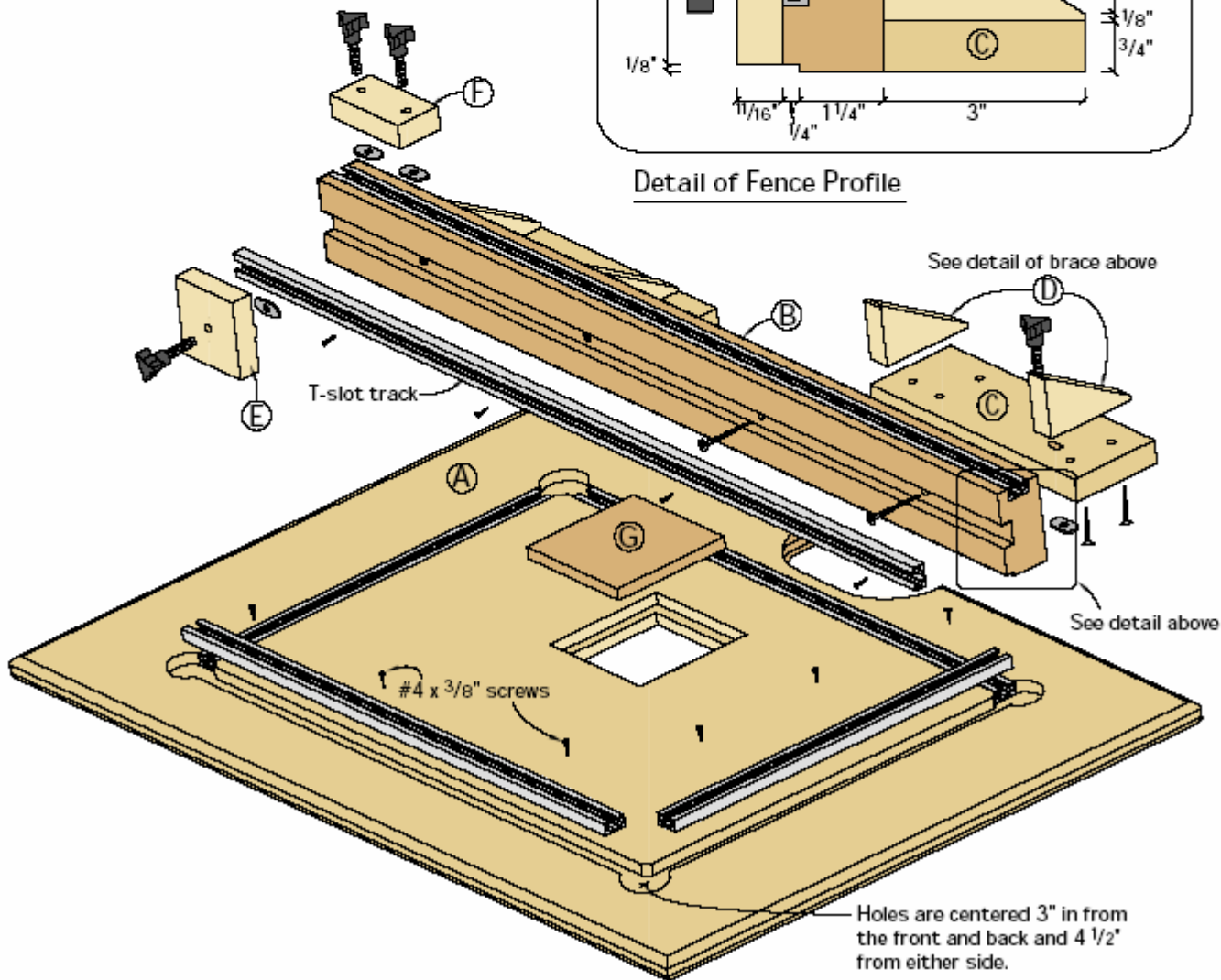
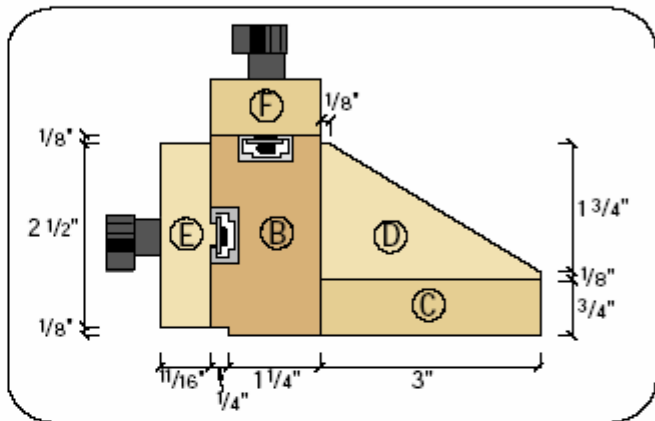

Start With the Base-ics

The base platform for the table is made from 3/4" plywood, which should be void-free. Again, adjust the size as necessary to fit your drill press. First you need to get the table ready for the T-track, which is what holds the fence and hold-downs in place. Start by locating the four recessed holes that allow the T-slot mechanism to slip into the track without disassembling the mechanism. Each hole is 1-1/2" in diameter and 3/8" deep.

Next, locate the grooves in the center of the holes and use a router with a 3/4"-wide straight bit to cut the grooves to a 3/8" depth. The T-slot track should fit into the grooves with the top surface just below that of the plywood table. The grooves should be as parallel as possible to one another to allow smooth movement of the fence.

Replaceable Center

Now cut the hole for the 4" x 4" replaceable insert. First locate and mark the position centered on your table, then mark in from that line by 3/8" to locate your cutting line. Drill clearance holes in two corners of the square, then use a jigsaw to cut out the center piece. Next, determine the thickness of the material you will use for your insert (the 3/8"-thick Baltic Birch we used is actually metric and shy of 3/8") and set a 3/8" piloted rabbeting bit in a router to a height to hold the insert flush to the top surface of the table.

While your jigsaw is still out, locate, mark and cut out the notch in the back of the table. This allows the table to move closer to the drill press' post and tilt without interference.

As a final friendly touch on the table, I used a 3/8" roundover bit in my router to soften all the edges on the table, both top and bottom. You'll get fewer splinters if you do this.

Milling the Fence

The fence is the heart of the table, and the wood should be chosen for durability and straightness. Quartersawn hardwood, carefully surfaced and planed, will do nicely. After cutting the fence to size, use a dado stack to mill two 3/8"-deep by 3/4"-wide grooves in the fence. The first is centered on the top surface of the fence, and as in the grooves in the base platform, a piece of T-slot track should be used to confirm that the groove is deep enough to allow the track to fit just below the surface of the wood. The second groove is then cut centered on the face of the fence. One other bit of table saw work is the 1/8" x 1/4" wide rabbet cut on the inside bottom edge of the fence. This rabbet allows dust and debris to be pushed into the rabbet, so your work will fit against the fence.

One option that I considered was adding an indexing tape measure on the fence. Every time the table is moved the tape would need to be readjusted to zero, and for the infrequent use the tape would see I decided against it. A stick-on tape can easily be added to the fence face if that's more to your personal taste and needs.

Fence Support Braces

Unlike the fence on a router table, the fence on a drill press table won't see a lot of lateral pressure. So the main purpose of the braces is to hold the fence square to the table at the drilling point. In my case I've also given the braces the job of mounting the fence to the table.

Start by cutting the two base plates and the four braces to size. The braces are triangles with the bottom edge 3" long and the adjoining right angle edge 1-7/8" long. The third side is determined by simply connecting the corners. Locate the braces on the base plates according to the diagrams and pre-drill and countersink 3/16" diameter holes in the base plates to attach the braces to the plates.

To mount the support braces to the fence, again refer to the diagrams to locate the proper spacing on the fence. Then drill and countersink screw holes through the face groove in the fence. Clamp the brace to the fence and screw the brace in place.

With the braces attached to the fence, use the T-slot fastener locations on the diagrams



Another view of the drill-press table. Here I'm cutting pocket holes in a table apron.



ROUT THE GROOVE The grooves for the T-slot track allow the fence to be used left-to-right and front-to-back on the table to take advantage of the built-in tilting feature of the existing table.



RABBET FOR THE INSERT After cutting the hole with a jigsaw, the opening is rabbeted using a bearing-piloted router bit. Then chisel the corners square and fit the replaceable center tightly into the rabbet. Make a couple extras.



ROCK SOLID The fence is made of a sturdy, stable hardwood. Cut a groove the length of the top and face of the fence. The grooves support T-slot tracks, which can be used for stops, hold-downs and other accessories.

as a starting point for drilling the holes in the base plates, but check the location against your table for the best fit. Two holes are drilled in each plate to allow the fence to be moved to the perpendicular position (either to the right or left of the quill), by simply relocating one of the T-slot fasteners. Check each hole in relationship to that position.

Attaching the Track

Assuming you purchased the 24" lengths of track listed in the Schedule of Materials, you should be able to cut the tracks for the table first, leaving fall off that can be added to the two remaining full length tracks to give you the necessary 30" lengths of track for the fence. When attaching the track, first pilot drill the hole in the center of the track (a groove is provided in the track to simplify that location), then use a countersink to widen the hole to accommodate a #4 x 5/8" flat head screw. Keeping the screws as flush as possible to the inner surface of the track will make the stops and hold-downs move much easier.

Finishing Touches

Stops and hold-downs designed for use in T-tracks make the drill press most useful. The stops are simply square blocks of wood with one side milled to leave an indexing strip that fits into the slot on the T-slot track. By using the saw to cut tall but shallow rabbets on two edges of each block, the stops are completed fairly easily. For safety, run the rabbet on a longer 2-1/2" wide piece of wood, then cut the stops to square afterward. The T-slot fasteners are simply inserted into a 1/4" hole drilled in the center of each stop block.

The hold-downs are simply blocks of wood with DeStaCo clamps mounted to the top. Each block is drilled for two T-slot fasteners, one on either end. Then the clamp is screwed to the top surface of the block. While the DeStaCos are good for this application, they aren't as versatile as I wanted. I replaced the threaded-rod plunger with longer all-thread (1/4" x 36) to provide maximum benefit from the clamps. The rubber tip of the plunger is important to the function of the clamp, and if you can manage to reuse the existing tip it's very helpful. If not, I found rubber stoppers in a variety of sizes in the local Sears hardware store. After carefully drilling a 1/4"-diameter hole two-thirds of the way into the stopper I was able to screw it onto the rod with little difficulty.

Attaching and Personalizing

The table should attach easily to your existing drill press table using four lag bolts countersunk flush into the surface of the auxiliary table. Once attached you should find that the auxiliary table overhangs the metal table quite a bit. One personalized touch I want to suggest is adding small drawers to the underside of the table to store bits, wrenches and chuck keys..



FENCE BRACES The fence is supported by two simple brackets screwed to the rear of the fence. The location of the triangular braces is important to the track orientation, so follow the diagrams carefully for location.



LAYING TRACKS Install the T-slot tracks in the grooves with flat head screws countersunk into the track. The braces are attached to the fence by screwing through the face groove prior to attaching the T-slot track.



HOLD IT The hold-downs and stops are made from 3/4" hardwood. To make the guide to hold the stops square to the fence, cut a 1/16" x 1-1/8" rabbet on both sides of the inside face.