

## The Classical Craftsman Mantle

Simple and clean lines represent this style, accentuated here with a focus on horizontal lines.

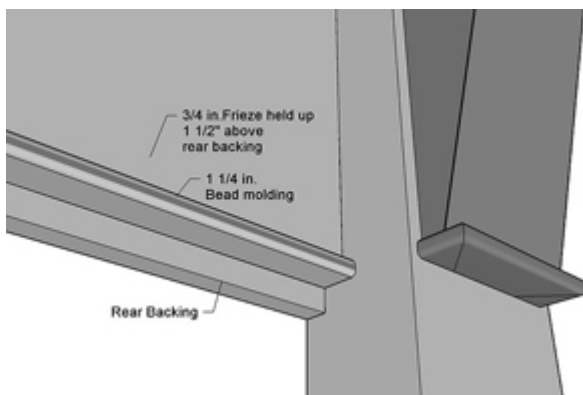
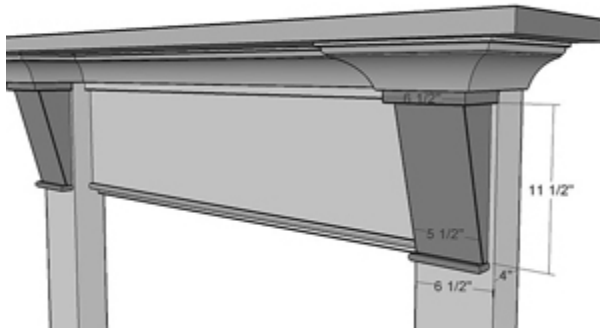
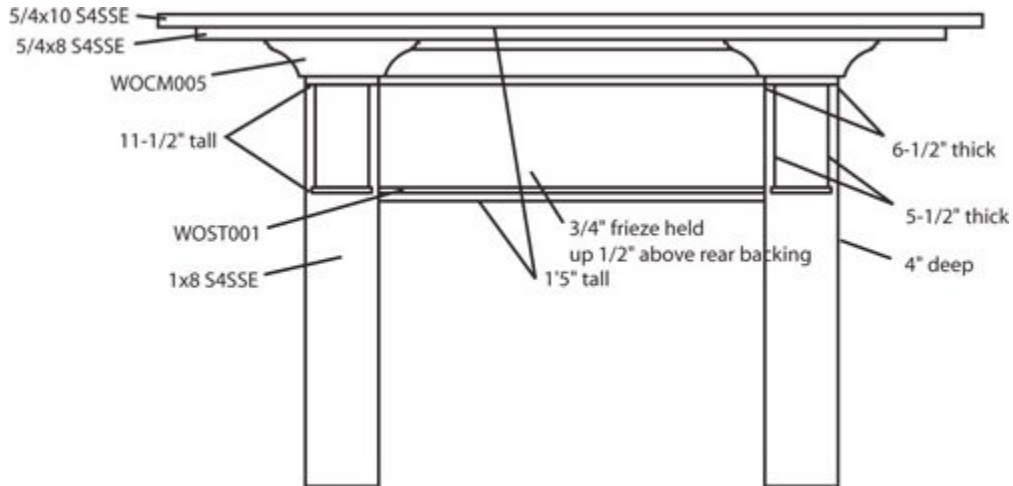

## The Classical Colonial Mantle

Typical for the period is the picture frame above the mantle and use of the bed molding (CM003) for the architrave.

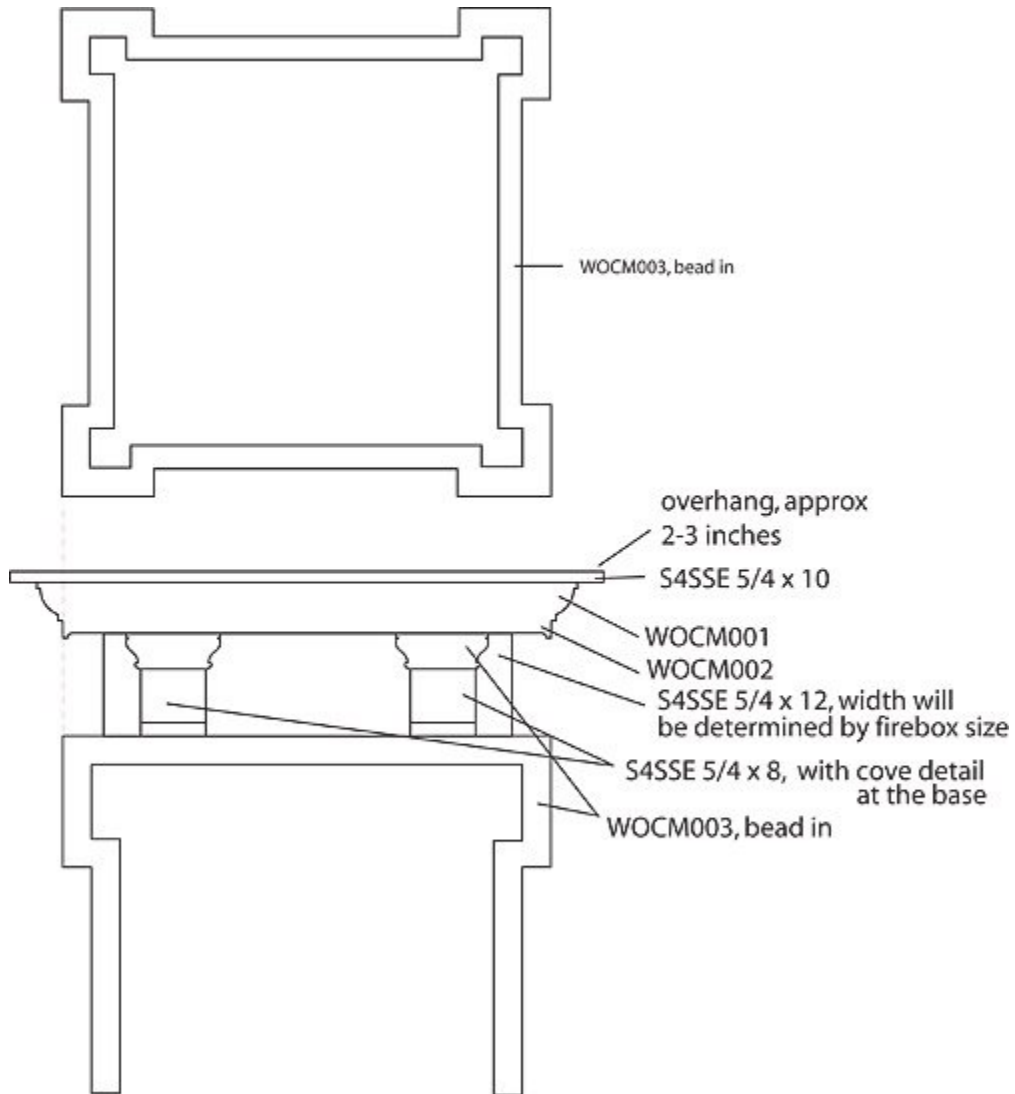

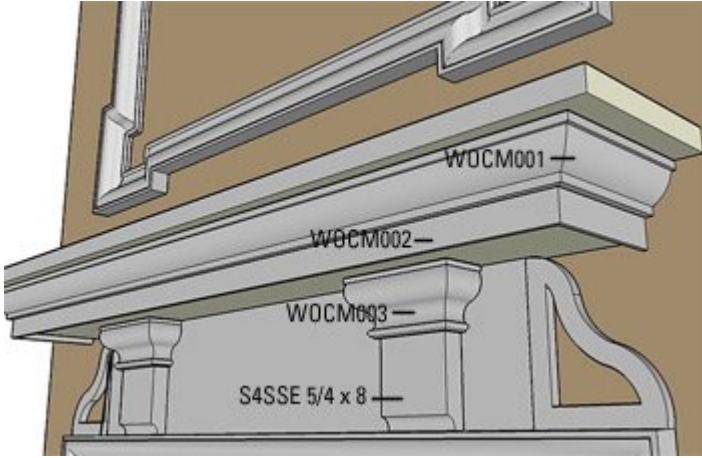

Dimensions and lengths will be dictated by the actual dimensions of the firebox.

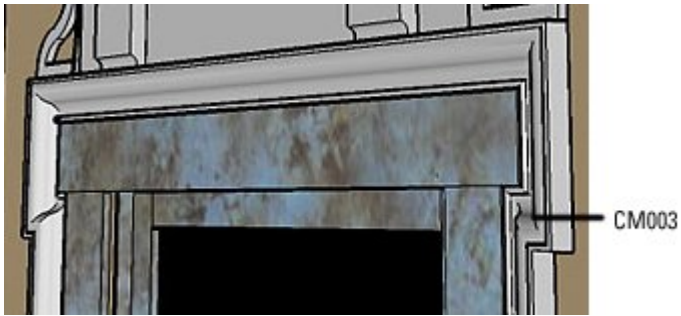

**The Greek Revival Mantle**

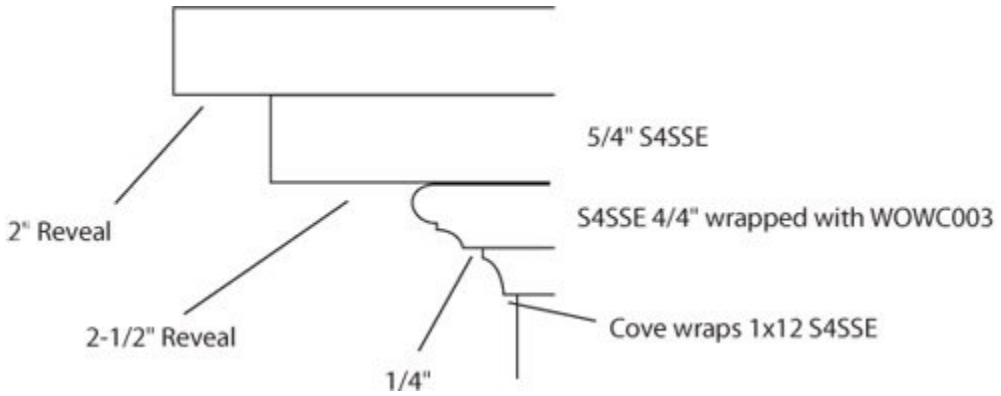

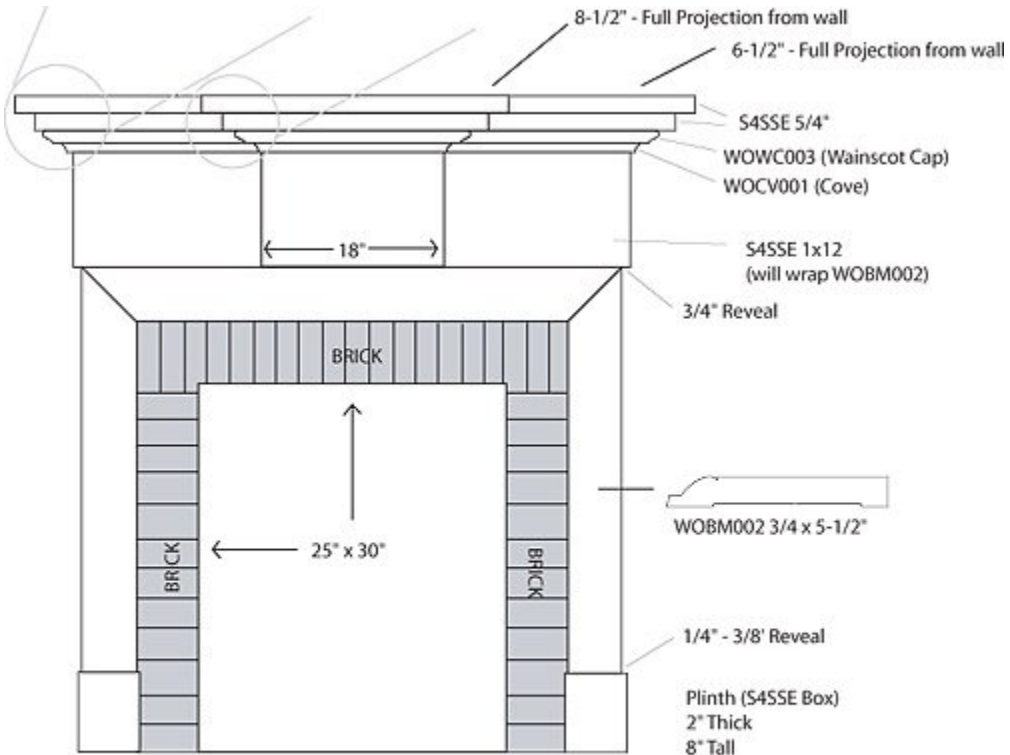

Material List  
 S4SSE 1x8, 1x12, 5/4x8  
 WOBM002  
 WOCV001  
 WOWC003

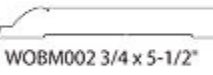

1/4" - 3/8" Reveal  
 Plinth (S4SSE Box)  
 2" Thick  
 8" Tall  
 6" Wide





**The Colonial Revival Mantle**

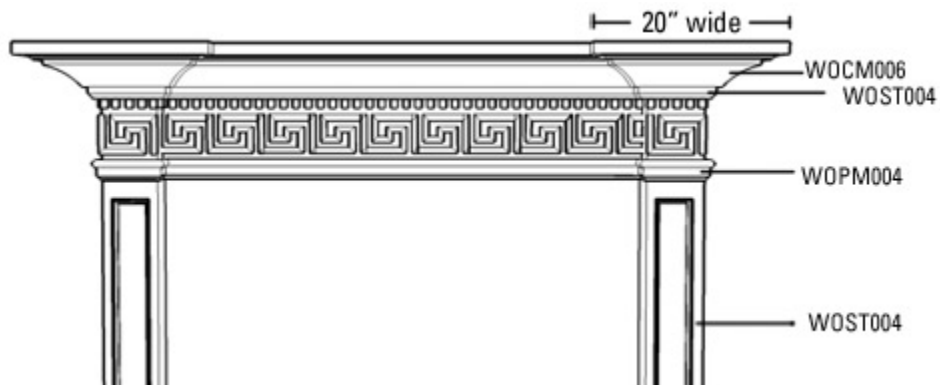

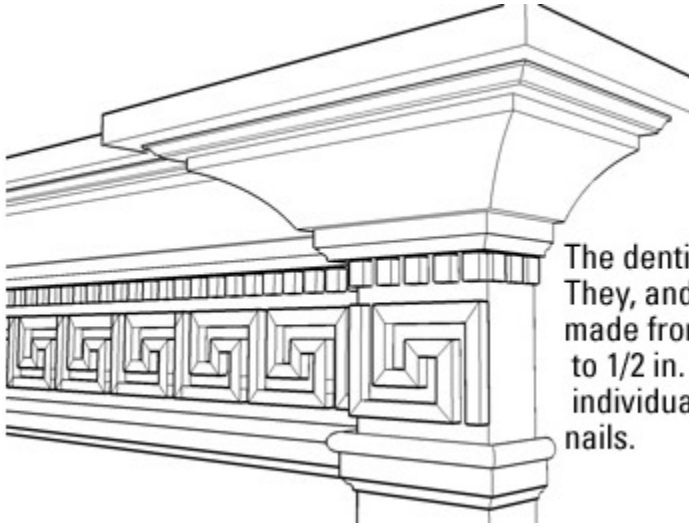

The dentil blocks are a must. They, and the fretwork, can be made from WO boards, re-sawn to 1/2 in. thickness, and applied individually with glue and pin nails.

