

CASSETTE HOLDER

Materials

Wood Selection

The two basic categories of wood used most often in wood working projects are hardwood and softwood. Hardwood is more durable and less prone to dents and scratches. It is also more expensive but will finish to a better advantage. Soft woods, like pine, are more prone to dents and scratches and do not have the durability of hardwood. Softwoods are much less expensive and easier to find.

Ask your lumber supplier to show you "Class 1 " or "Select Grade" lumber. Make sure it is properly dried, straight, and free of knots and defects. (It may be impossible to be completely free of defects but be sure you understand how to cut around these.)

Ask your Lumber supplier for assistance when purchasing your wood. Similar to laying a pattern out on a piece of cloth, often you can cut several different pieces of the same thickness of wood out of a single piece. It is a good idea to add up the total number of board feet, being careful to make sure you group short pieces in a board with long pieces to minimize waste.

This project could be built out of scrap wood already in your workshop. If you choose to use new stock from the lumber yard, both hardwoods and softwood are good choices.

Note: Developing a good relationship with Your lumber suppliers is important. They can help guide you in making material selections as well as making special orders for a type of wood you may desire for a project.

Now that you have reviewed safety hints, learned the mistakes to avoid, reviewed the basic components and gathered your tools and materials for your projects - you are ready to BEGIN!

Steps to follow:



1. Cut the wood to size.
2. Cut the dados for the shelves.
3. Bevel the shelves.
4. Drill holes for the rods. (Depending on the size of your sides you can have one or two sets of rods.)
5. Assemble the cassette holder.

Cut the Wood to Size

For this project there are two sides, two shelves, and rods. Wood from a lumber yard may not be square so square the ends before cutting the stock.

1. Crosscut the stock using a table saw with a stop block. Note: do not cut the shelves at this time because of the bevel cuts to be made later. Guide the wood through with the miter gauge. Note: Do not use a miter gauge with the rip fence as it may cause the wood to bind.
2. Rip the stock. Measure from the rip fence to the inside of the blade so that the cut is made on the scrap side of the wood and is the proper dimension.

Cut the Dadoes for the Shelves

Check your plans for the exact location of the dado cuts.

1. The dadoes on this project are cut at a 45 degree angle. Use a table saw with a dado set to make the cuts. A miter gauge with an extension fence and stop block will assure an accurate cut. A router with a guide board clamped at the correct angle can also be used to make the dado cuts. Note: Always start the router away from the wood and ease it up after the bit is up to speed, to make a clean cut.

Bevel the Shelves

Tilt the table or the table saw blade at a 45 degree angle. A circular saw can be used for this step by tilting the guide and blade at a 45 degree angle.

1. If you are using a circular saw, clamp on a guide to assure accuracy.
2. Check to make sure the angle is correct, and cut the shelves.

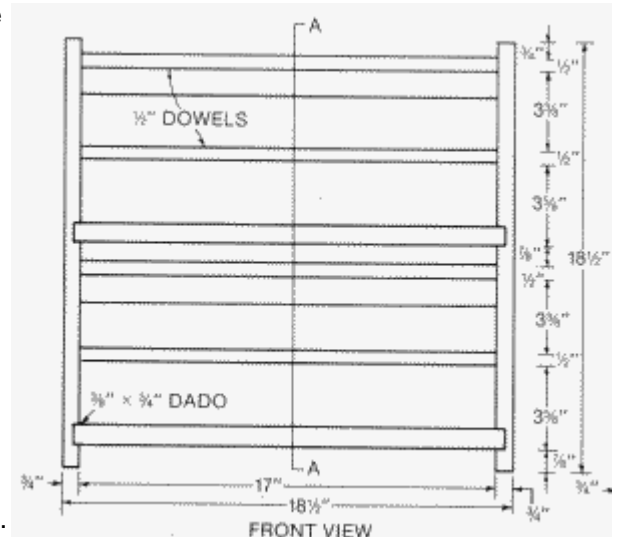

Drill the Holes for the Rods

Use a drill or a drill press to make the holes.

1. Measure according to the plans for the hole locations and mark them.
2. Set the depth for the hole to be drilled. A depth gauge can be made with a piece of tape wrapped around the bit if you are not using a stationary tool.
3. Drill the holes for the bars.

Assemble the Cassette Holder

1. Sand the pieces before assembling.
2. Assemble the unit dry to check for proper fit.
3. Apply wood glue to all edges and rod ends. Then use clamps to hold tight while drying.
4. Apply finishing nails while drying for additional strength.
5. Sand the rack and apply the finish you have selected according to the manufacturer's instructions. There are helpful hints on finishing at the end of this pamphlet.

