

# 8th Grade

# Transformations

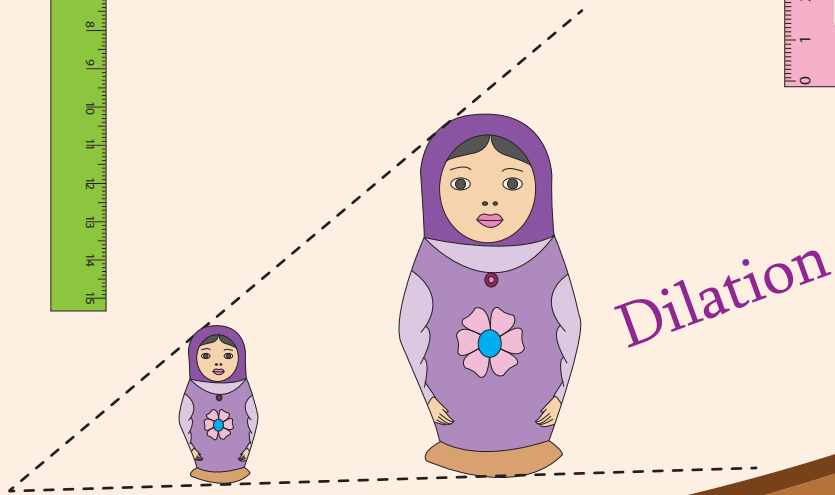
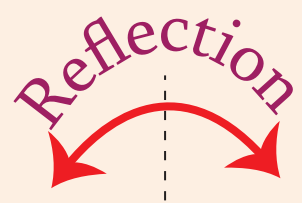
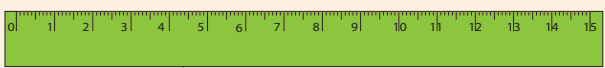
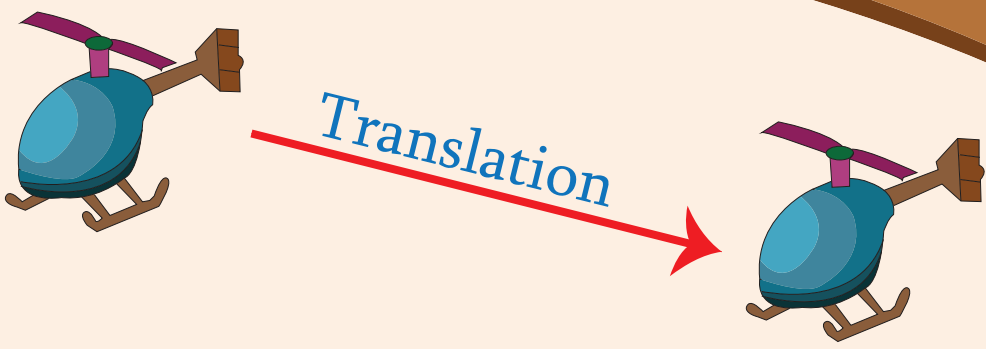

# Workbook 1

## Translation of Shapes

Graph the image of each shape using the translation given.

1) 5 units down and 4 units right

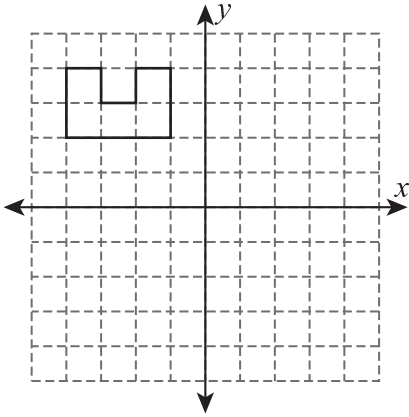

2) 2 units left and 6 units down

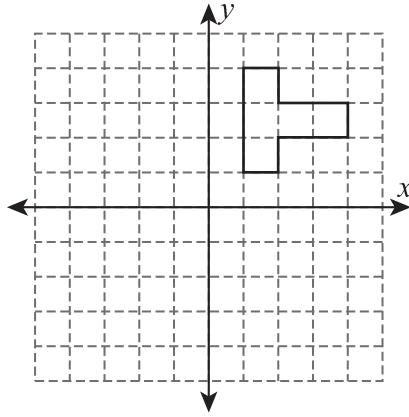

3) 7 units left

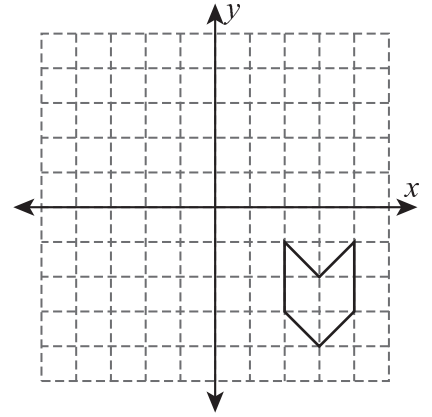

4) 2 units left and 3 units up

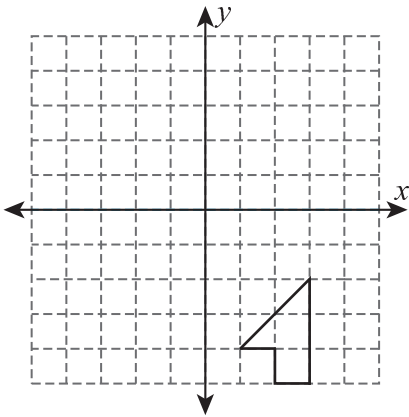

5) 6 units up and 8 units right

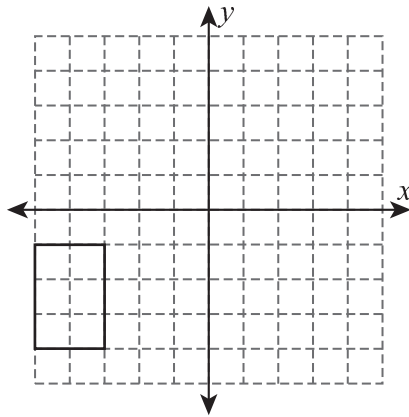

6) 1 unit right and 5 units up

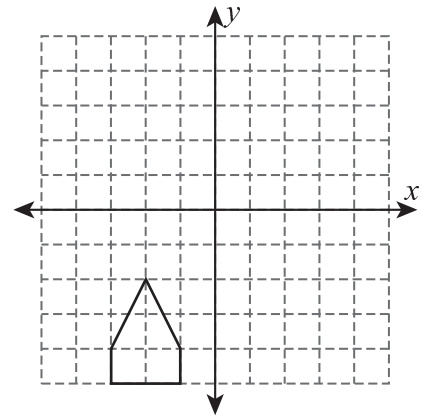

7) 3 units up and 1 unit left

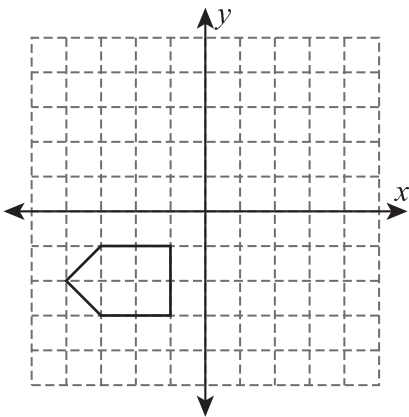

8) 5 units down

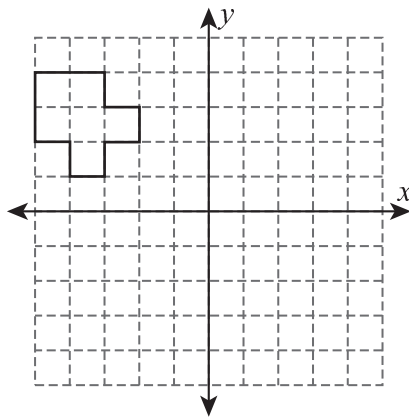

9) 2 units down and 4 units left

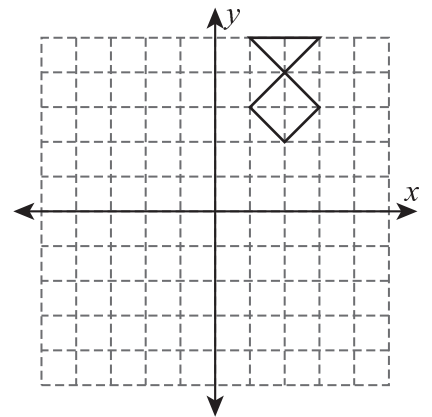

## Translation of Triangles

Graph the image of each triangle using the given translation.

1) 4 units down

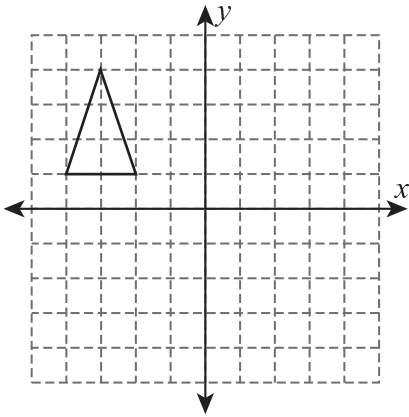

2) 6 units up and 5 units left

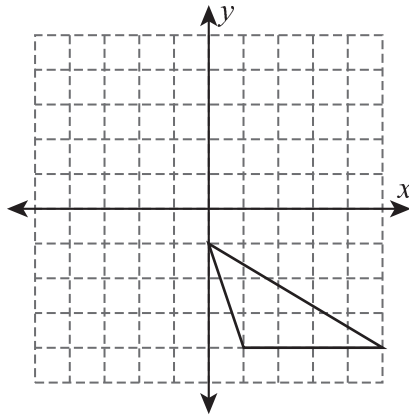

3) 5 units right and 3 units down

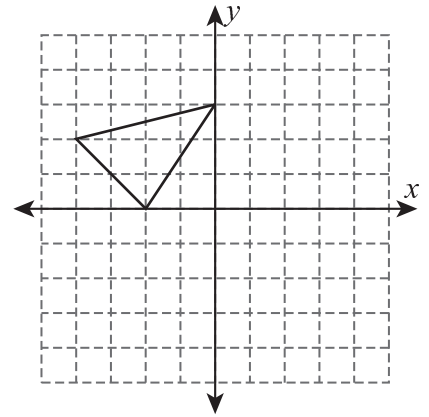

4) 5 units left and 1 unit down

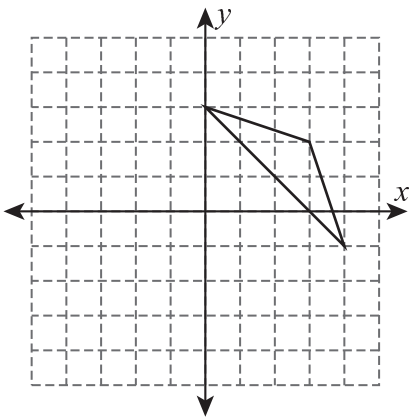

5) 7 units right and 2 units up

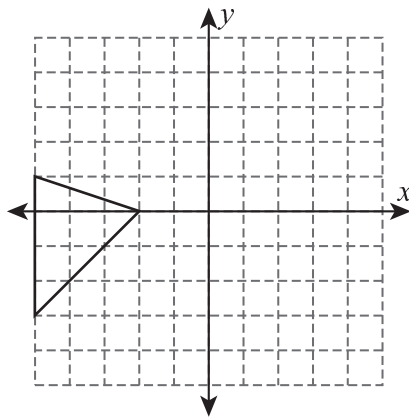

6) 3 units down and 4 units left

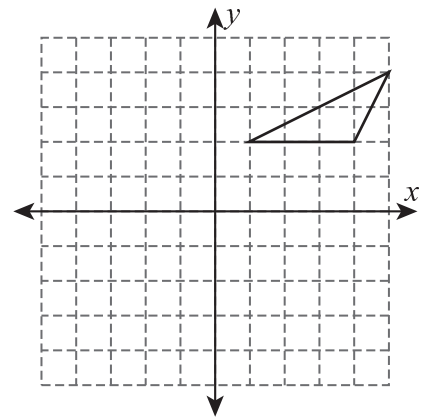

7) 2 units up and 6 units right

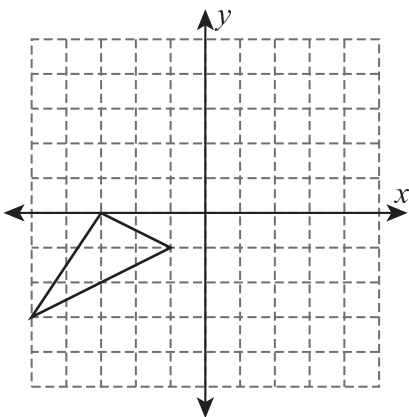

8) 4 units down and 1 unit right

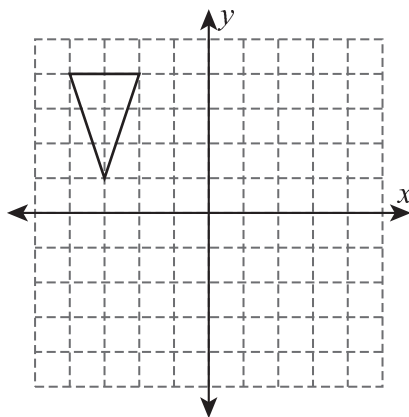

9) 8 units left and 7 units up

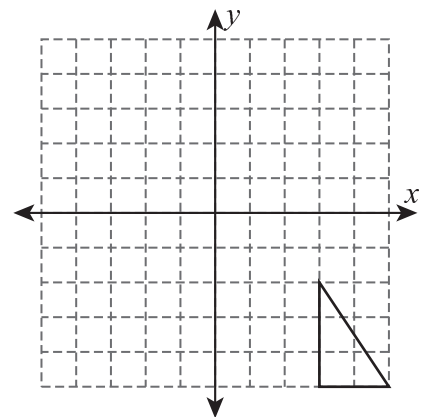

## Translation of Quadrilaterals

Graph the image of each quadrilateral using the translation given.

1) 3 units up and 5 units left

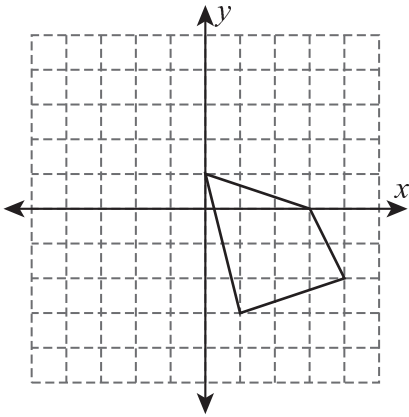

2) 6 units right and 4 units up

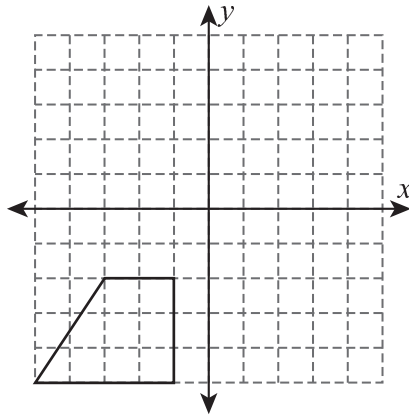

3) 7 units down and 2 units right

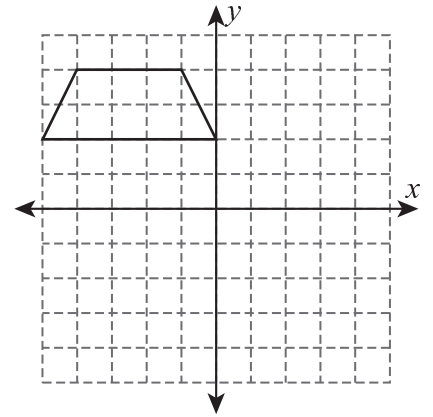

4) 8 units down

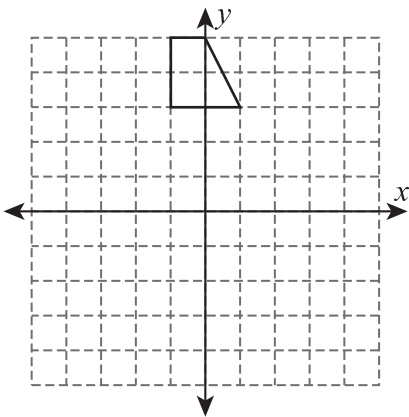

5) 5 units down and 3 units left

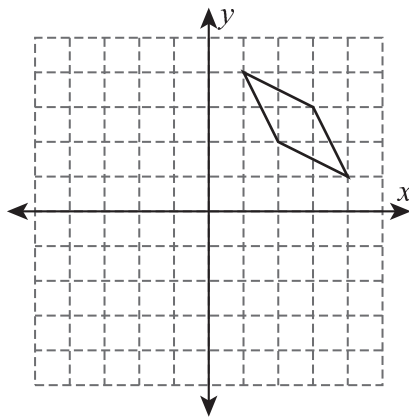

6) 4 units up and 4 units right

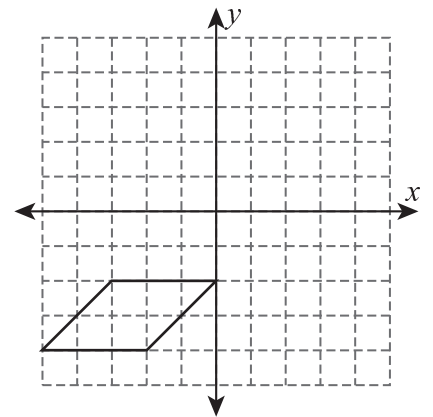

7) 4 units down and 7 units right

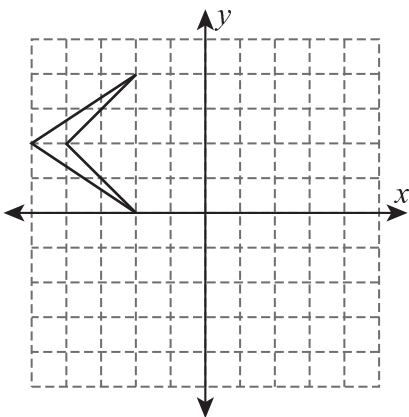

8) 3 units left and 2 units up

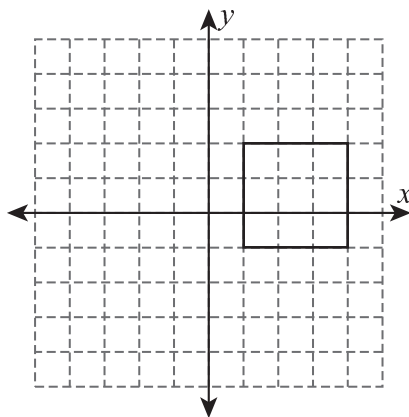

9) 6 units right and 1 unit down

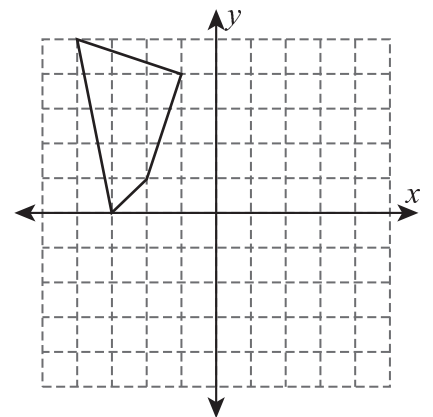

## Rotate the Shapes

Graph the image of each shape after rotating it about the origin.

1)  $180^\circ$  rotation

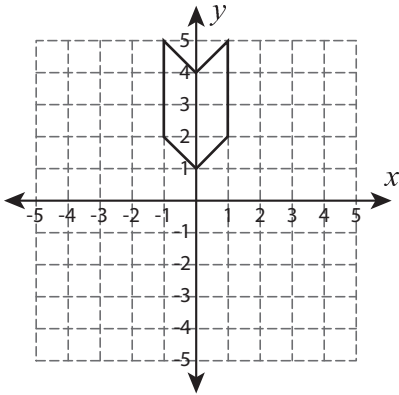

2)  $90^\circ$  clockwise rotation

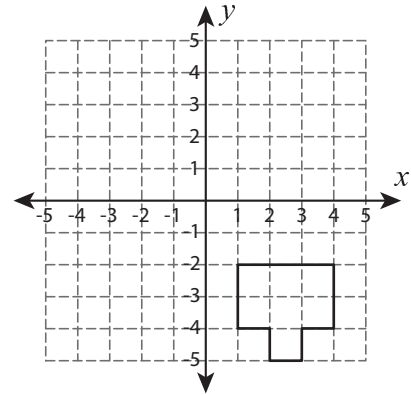

3)  $90^\circ$  counterclockwise rotation

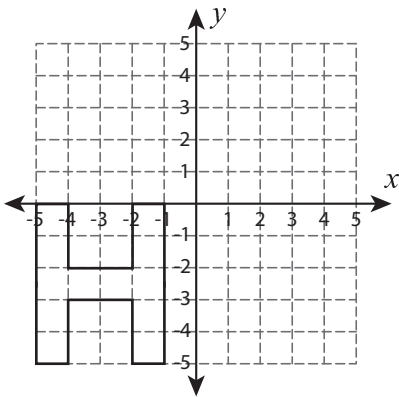

4)  $180^\circ$  rotation

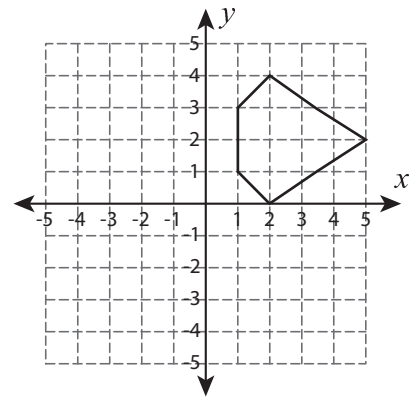

5)  $90^\circ$  clockwise rotation

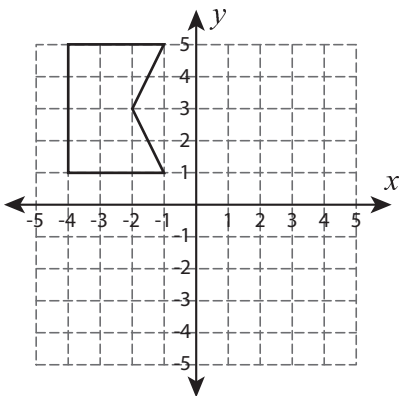

6)  $90^\circ$  counterclockwise rotation

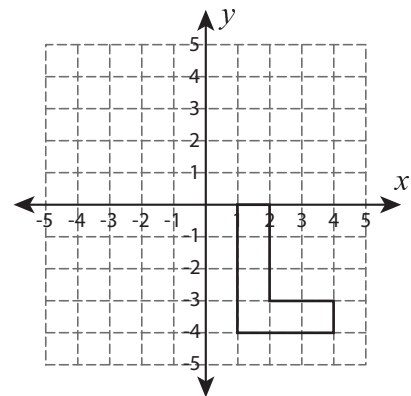

7)  $180^\circ$  rotation

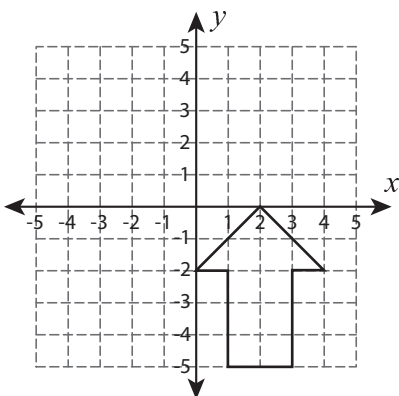

8)  $90^\circ$  clockwise rotation

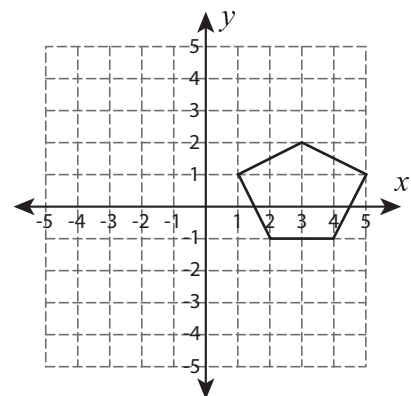

Pages 5 to 12 are available only for members.

Subscribe for unrestricted access to  
200+ workbooks and 30,000+ worksheets for  
just **\$19.95/year.**

Scroll down for additional free pages.

## Transform the Quadrilaterals

Graph the image of each quadrilateral after the given transformation.

1) Reflection across the line  $y = 1$

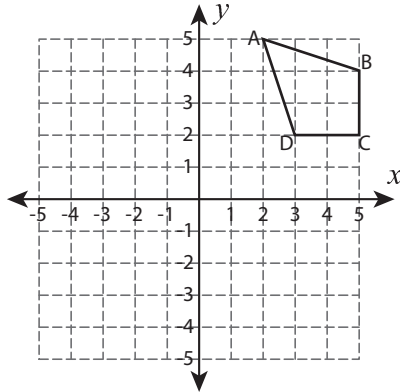

2)  $90^\circ$  counterclockwise rotation about the origin

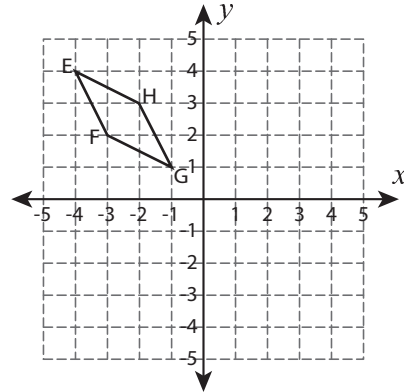

3) Translate 3 units down and 4 units right

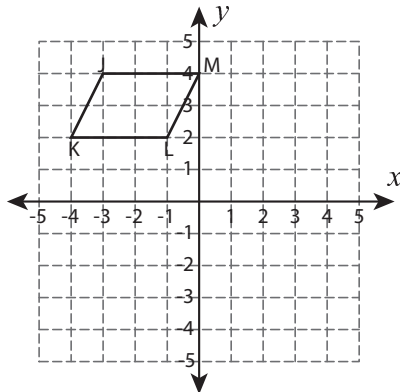

4) Reflection across the line  $x = -1$

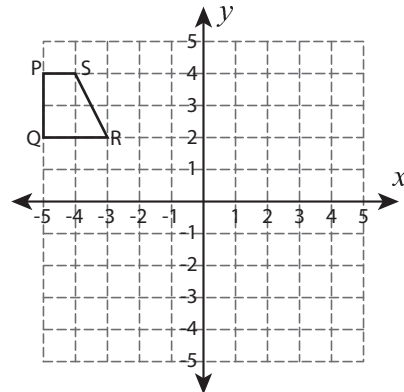

5)  $90^\circ$  clockwise rotation about the origin

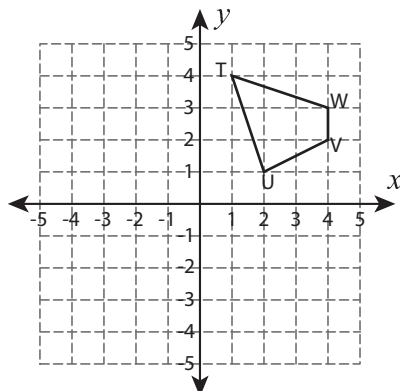

6) Translate 6 units up and 2 units left

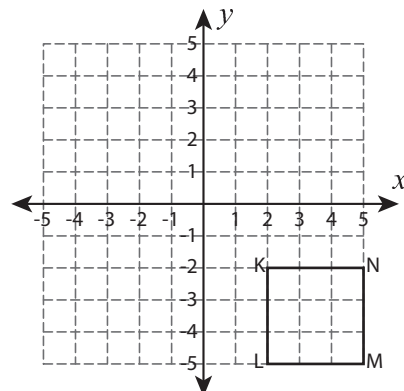

7) Reflection across the line  $y = -2$

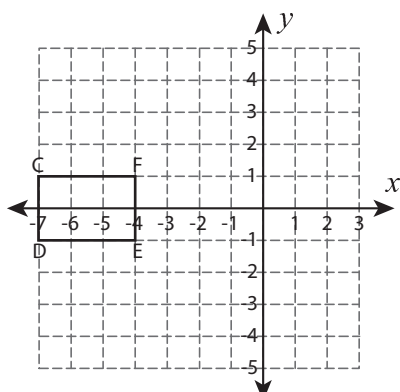

8)  $180^\circ$  rotation about the origin

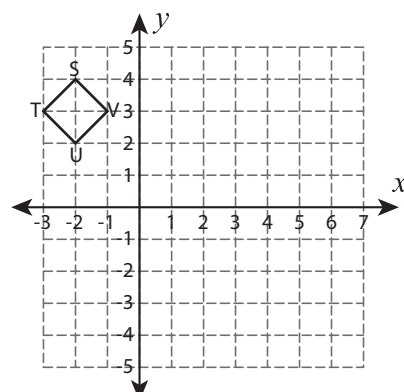

# Multiple Choice

Choose the correct transformation.

1)

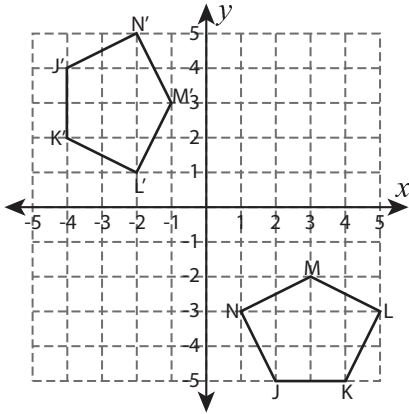

- a) reflected, then translated
- b) rotated, then translated
- c) rotated, then reflected

2)

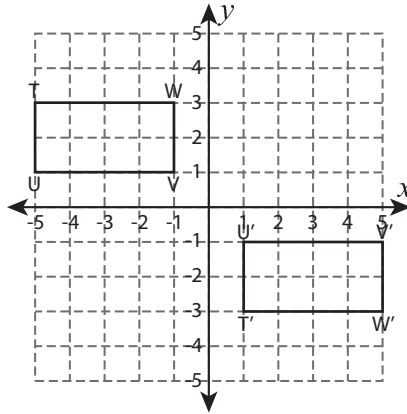

- a) translated, then reflected
- b) reflected, then rotated
- c) translated, then rotated

3)

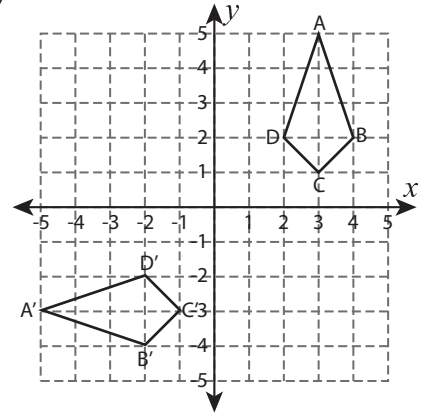

- a) rotated, then translated
- b) translated, then reflected
- c) reflected, then rotated

4)

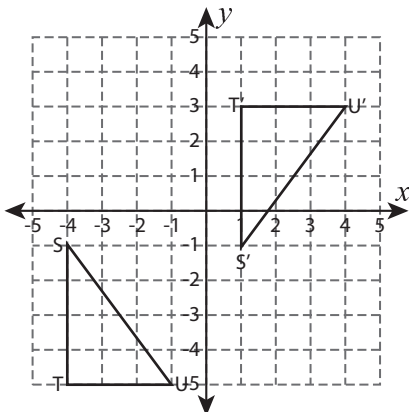

- a) rotated, then reflected
- b) translated, then rotated
- c) reflected, then translated

5)

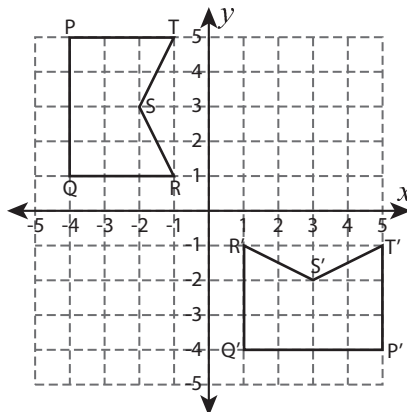

- a) translated, then reflected
- b) rotated, then reflected
- c) rotated, then translated

6)

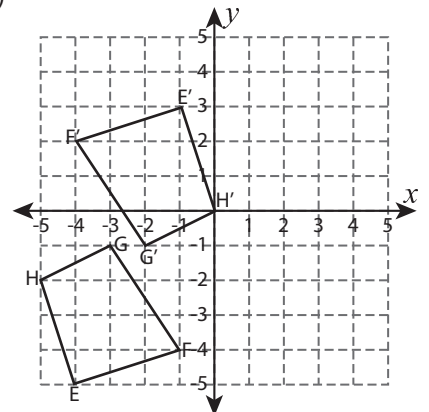

- a) translated, then rotated
- b) reflected, then translated
- c) rotated, then reflected

## Translation - Function

Write the translated function.

1)  $f(x) = 12x + 3$  ; shifts 2 units left.

$$g(x) = \underline{\hspace{2cm}}$$

2)  $f(x) = -7x - 4$  ; shifts 5 units down.

$$g(x) = \underline{\hspace{2cm}}$$

3)  $f(x) = 11x + 10$  ; shifts 3 units up.

$$g(x) = \underline{\hspace{2cm}}$$

4)  $f(x) = 8x - 6$  ; shifts 7 units right.

$$g(x) = \underline{\hspace{2cm}}$$

5)  $f(x) = -5x + 7$  ; shifts 1 unit left.

$$g(x) = \underline{\hspace{2cm}}$$

6)  $f(x) = 6x - 12$  ; shifts 4 units down.

$$g(x) = \underline{\hspace{2cm}}$$

## Reflection

If  $g(x)$  is a reflection of  $f(x)$  across the given axis, then find  $g(x)$ .

1)  $f(x) = 4x + 2$  ; reflection across the  $x$ -axis.

$$g(x) = \underline{\hspace{2cm}}$$

2)  $f(x) = -3x - 10$  ; reflection across the  $y$ -axis.

$$g(x) = \underline{\hspace{2cm}}$$

3)  $f(x) = 14x - 3$  ; reflection across the  $x$ -axis.

$$g(x) = \underline{\hspace{2cm}}$$

4)  $f(x) = 2x + 8$  ; reflection across the  $y$ -axis.

$$g(x) = \underline{\hspace{2cm}}$$

5)  $f(x) = -9x + 15$  ; reflection across the  $x$ -axis.

$$g(x) = \underline{\hspace{2cm}}$$

6)  $f(x) = x - 2$  ; reflection across the  $y$ -axis.

$$g(x) = \underline{\hspace{2cm}}$$