

Pearson Edexcel Functional Skills

Mathematics

Level 1

Section A (Non – Calculator)



Sample assessment material for first teaching
September 2019
Time: 25 minutes

Paper Reference(s)

XXXX/XX

You must have:

Pen, HB pencil, eraser, ruler graduated in cm and mm, protractor, compasses.

My signature confirms that I will not discuss the content of the test with anyone.

Signature: _____

Instructions

- Use a **black** ball-point pen.
- **Fill in the boxes** at the top of this page with your name, centre number and candidate number.
- Sign the declaration.
- Answer **all** questions.
- Write your final answers in the boxes provided
- Answer the questions in the spaces provided – *there may be more space than you need.*
- You **must** show clearly how you get your answers in the spaces provided. Marks will be awarded for your working out.
- Check your working and your answers at each stage.
- Diagrams are **not** accurately drawn, unless otherwise indicated.
- **Calculators may not be used**
- Take the value of π to be 3.14

Information

- The total mark for this section is 14.
- The marks for each question are shown in brackets
 - *use this as a guide to how much time to spend on each question.*
- This sign shows where marks will be awarded for showing your checks.

Advice

- Read each question carefully before you start to answer it.
Keep an eye on the time

SECTION A

Answer ALL questions. Write your answers in the spaces provided.

- 1 A music festival sells tickets on its website.
There are one hundred and twenty thousand tickets for sale.

Festival news

118 200 tickets sold in the first hour.

How many tickets are still for sale after the first hour?
You **must** show your working.

(3)

(Total for Question 1 is 3 marks)

2

(a) Calculate 12^2

(1)

(b) Work out $80 - 6 \times 2$

(1)

(c) Work out $-18 - 14$

(1)

(Total for Question 2 is 3 marks)

3 Rosa makes candles to sell.

Each candle is in the shape of a cuboid of height 8 cm.
The base of each candle is a square of perimeter 20 cm.

Rosa needs to know the volume of one candle.

Work out the volume of one candle.
Remember to give units with your answer.

(3)



(b) Use reverse calculations to show a check of your answer.

(1)

4

(a) Round 11.348 correct to two decimal places.

(1)

Rashid works at an animal centre.

The animal centre sells tickets for 49 weeks of the year.

A student ticket costs £9.90

The animal centre sold 23 student tickets last week.

Rashid assumes that the same number of student tickets are sold each week.

He wants to estimate the income from the sale of student tickets for the year.

(b) Estimate the income from the sale of student tickets for the year.

(3)

£

(Total for Question 4 is 4 marks)

Pearson Edexcel Functional Skills

Mathematics

Level 1

Section B (Calculator)



Sample assessment material for first teaching
September 2019
Time: 1 hour 30 minutes

Paper Reference(s)

XXXX/XX

You must have:

Pen, calculator, HB pencil, eraser, ruler graduated in cm and mm, protractor, a pair of compasses.

My signature confirms that I will not discuss the content of the test with anyone.

Signature: _____

Instructions

- Use a **black** ball-point pen.
- **Fill in the boxes** at the top of this page with your name, centre number and candidate number.
- Sign the declaration.
- Answer **all** questions.
- Write your final answers in the boxes provided
- Answer the questions in the spaces provided – *there may be more space than you need.*
- You **must** show clearly how you get your answers in the spaces provided. Marks will be awarded for your working out.
- Check your working and your answers at each stage.
- Diagrams are **not** accurately drawn, unless otherwise indicated.
- If your calculator does not have a π button take the value of π to be 3.14

Information

- The total mark for this section is 42.
- The marks for each question are shown in brackets
 - *use this as a guide to how much time to spend on each question.*
- This sign shows where marks will be awarded for showing your checks.

Advice

- Read each question carefully before you start to answer it.
- Keep an eye on the time

SECTION B

Answer ALL questions. Write your answers in the spaces provided.

- 1 Ryan will drive his car in Spain.

The speedometer in the car shows the speed in miles per hour only.
He will be driving on a road with a speed limit of 100 kilometres per hour.

Ryan uses this rule to find this speed in miles per hour.

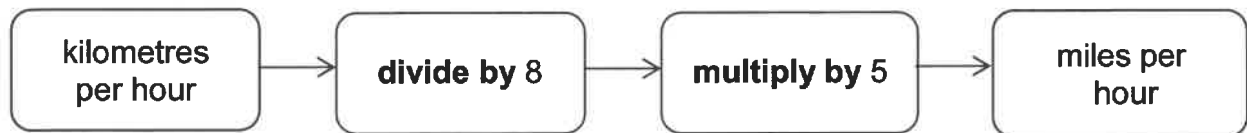

Ryan thinks that 70 miles per hour is the same as 100 kilometres per hour.

Is Ryan correct?

(3)

2 Nicola wants to buy 30 litres of white paint.

She sees this special offer.

<p>White paint 10 litre tin usual price £38</p> <p>15% discount</p>
--

Nicola uses this special offer.

She has a budget of £100 for the paint.

Does Nicola have enough money to buy 30 litres of white paint?

(4)

3 Luke wants to cover this wall with blue paint.

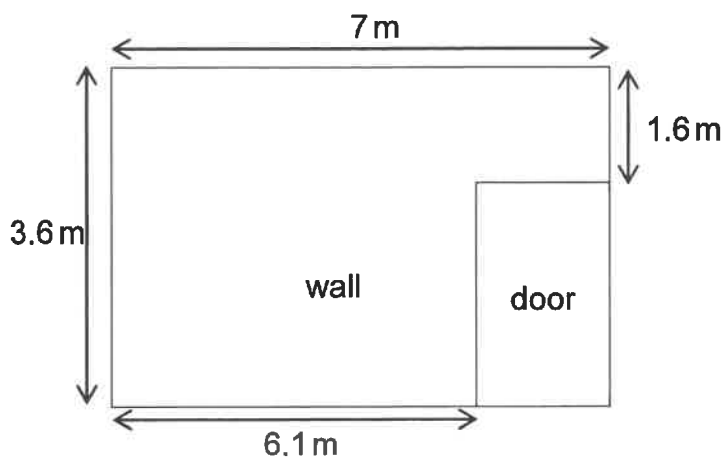

He will buy blue paint in 2.5 litre tins.

Each 1 litre of blue paint will cover 8 m^2 of the wall.

How many tins of blue paint does Luke need to buy?

(5)

tins

4 Chris is designing a badge.

The badge needs to

- be in the shape of a trapezium
- have a base of length 6 cm
- have only one line of symmetry.

Draw a suitable badge.

Use the grid below to draw a badge.

(3)

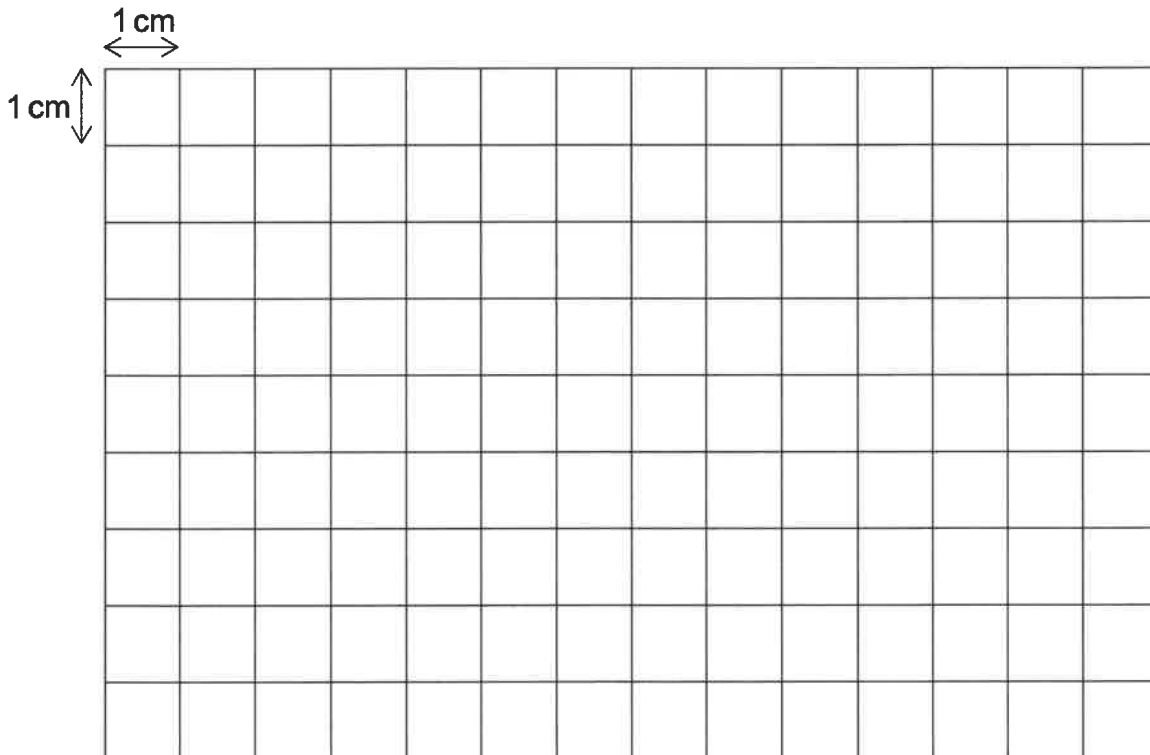

(Total for Question 4 is 3 marks)

- 5 Jimmy works in a shop.
He has this information about the 72 items sold last week.

Item	Number sold	Angle size
Tablet	15	75
Phone	44	
Laptop	13	

Jimmy starts to display this information in a pie chart.

Complete the pie chart for Jimmy.

(3)

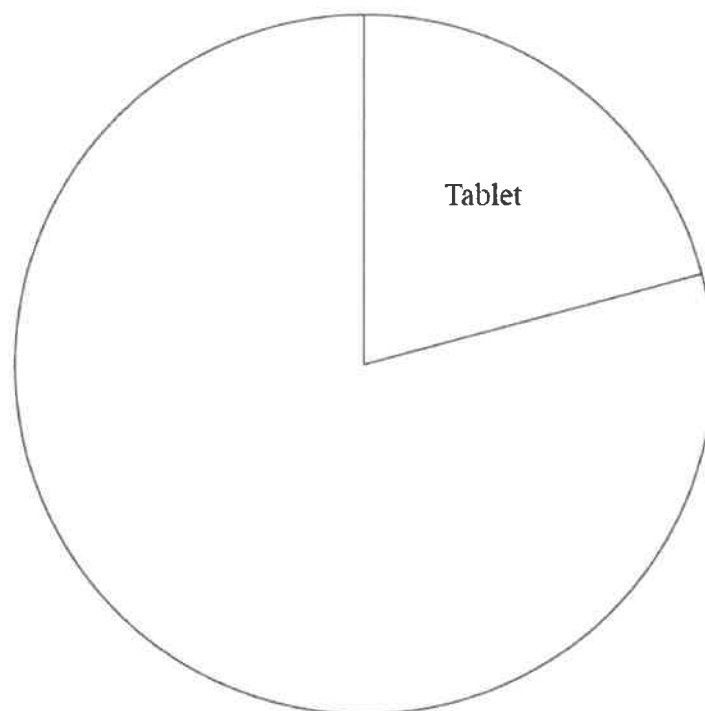

- 6 Ben is an activity leader.
He is planning a team-building event for a group of people.
Ben has this part of a map.



Diagram drawn accurately

Key: 1 cm on the map is 1000 m on the ground

The group will start at point A and walk directly to point B.

Ben needs to write instructions to give to the group.

The instructions need to include the

- bearing
- distance to be walked.

(a) Write the instructions for the group.

Remember to give units with your answer.

(4)

Ben records the time it took each person to complete a different event.

He is completing a table with information.

	Time (minutes)
Mean	39
Range	26
Longest time	53
Shortest time

(b) Complete the table.

(2)

(Total for Question 6 is 6 marks)

7 The table shows the price of a cup of tea in 5 different cafes.

cafe	A	B	C	D	E
price	£1.80	£1.59	£1.65	£1.45	£1.70

Calculate the mean price of a cup of tea.

(3)

£

(Total for Question 7 is 3 marks)

8 Here is a cube of side length 3 cm.

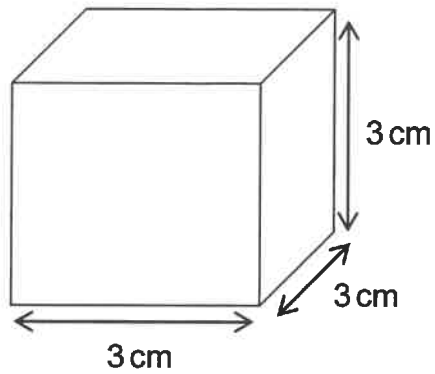

Draw a net of the cube.
Use the grid below to draw your net.

(3)

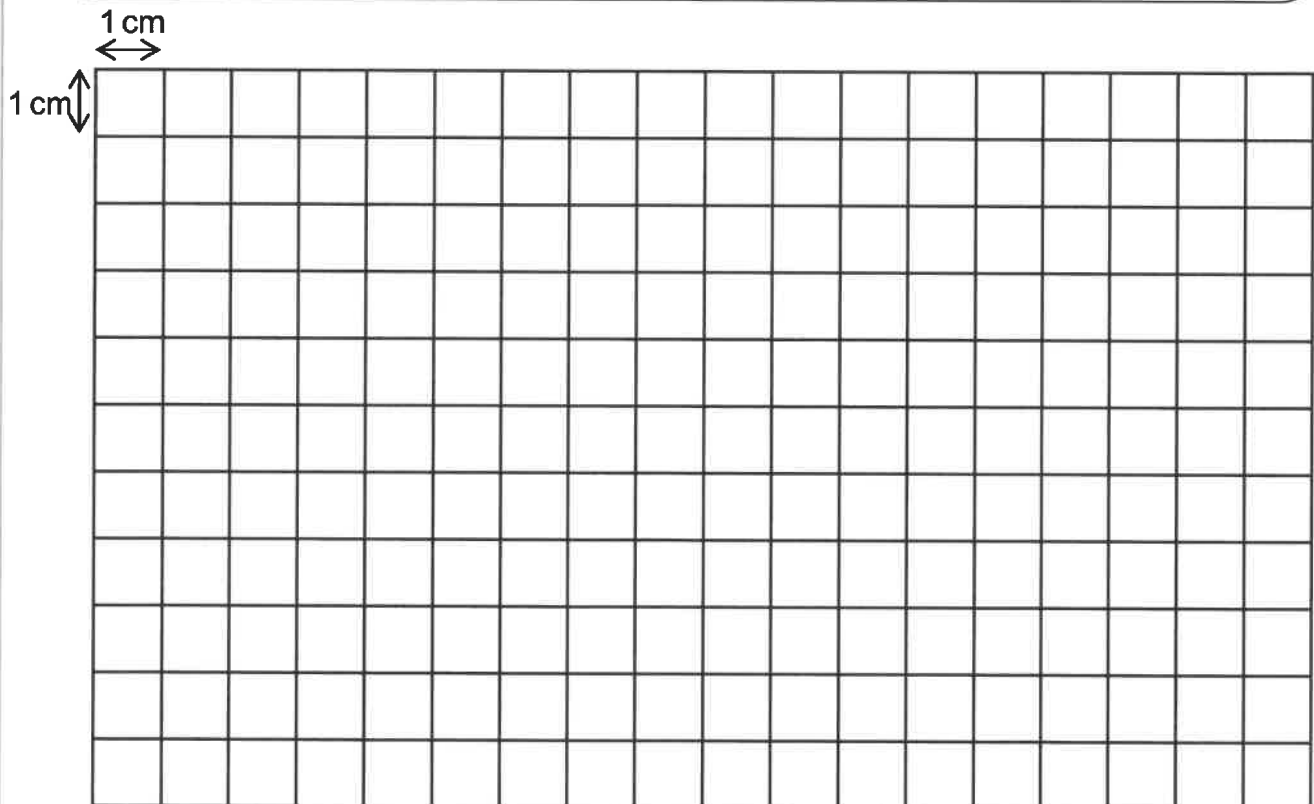

(Total for Question 8 is 3 marks)

9 Charlie works in a beauty salon.

He has three appointments today.

The time needed for each appointment is

- Mrs Green ($1\frac{1}{2}$ hours)
- Ms Price (1 hour 20 minutes)
- Sam ($3\frac{1}{4}$ hours).

He will have a 45 minute break.

Charlie will start work at 9:15 am

He wants to finish work by 4:30 pm

Will Charlie finish work by 4:30 pm?

(4)

(Total for Question 9 is 4 marks)

10 Oscar is organising a show.

Visitors to the show choose their seats at random.

There are 350 seats available.

These seats are numbered from 1 to 350

Oscar places a prize under each of the seats numbered 17 to 25

(a) What is the probability that the first visitor chooses a seat with a prize?

(2)

The probability that a visitor buys a soft drink at the show is $\frac{3}{4}$

(b) Which of these describes this probability?

(1)

Tick [] a box to show your answer.

- impossible
- unlikely
- even chance
- likely
- certain

(Total for Question 10 is 3 marks)

11 Holly works at a garage.

Mr Bakir brings his car in for a service.

He also buys 2 tyres and a battery.

Holly has this list of costs

- service £110
- tyres £49.99 each
- battery £89

She uses this list to start to work out the bill for Mr Bakir.

Holly also has to charge 20% VAT on the costs to work out the total bill.

(a) Work out the total bill.

(4)

£



(b) Use estimation to show a check of your answer.

(1)

(Total for Question 11 is 5 marks)

TOTAL FOR SECTION B = 42 MARKS