



GCSE Target Work

AQA Exam Questions 2nd Half Term Targets

Name:

Contents

Targets.....	Page 2
QR Codes.....	Pages 3-4
2D Shapes.....	Pages 5-16
3D Shapes.....	Pages 17-27
Angles.....	Pages 28-39
Angles in Polygons	Pages 40-43
Probability	Pages 44-61
Averages.....	Pages 62-78
Indices	Pages 79-83
Standard Form.....	Pages 84-88
Compound Interest	Pages 89-98
Sequences	Pages 99-114
Pythagoras	Pages 115-129
Frequency Trees.....	Pages 130-144
Venn Diagrams	Pages 145-157
Notes.....	Pages 158-160

QR Codes



Area



Compound Shapes



Volumes of Prisms



Angles on Parallel Lines



Angles in Polygons



Probability



Probability Tables



Modal Interval and
Estimated Mean



Indices



Standard Form



Compound Interest



Sequences



Frequency Trees



Venn Diagrams

2D Shapes

Q1.

A diagonal of a rectangle is drawn on a centimetre grid.
The sides of the rectangle are on the grid lines.

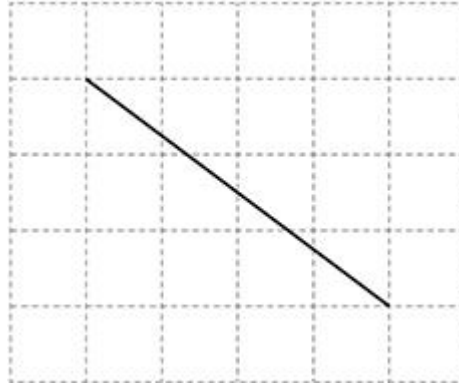

Work out the area of the rectangle.

Answer _____ cm²
(Total 2 marks)

Q2.

One side of a parallelogram is drawn on this centimetre grid.
The parallelogram does **not** have any right angles.

Complete the parallelogram so that it has area 24 cm²

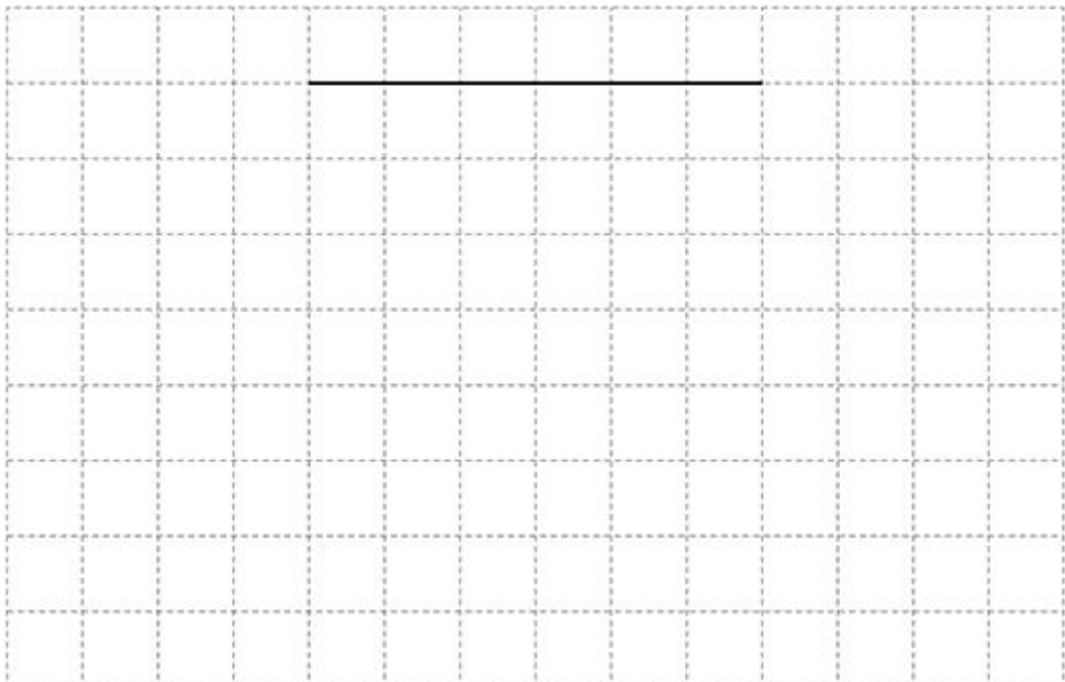

(Total 2 marks)

Q3.

The L-shape is made from rectangles.

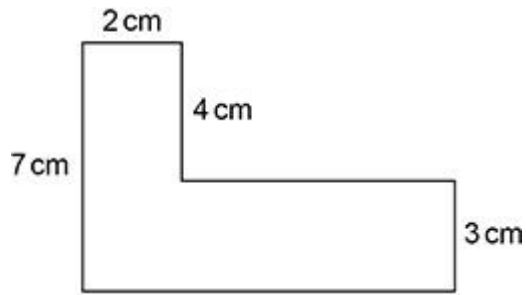

Not drawn accurately

The area is 44 cm^2

Work out the perimeter.

Answer _____ cm
(Total 3 marks)

Q4.

A shape is made using 15 identical rectangles.

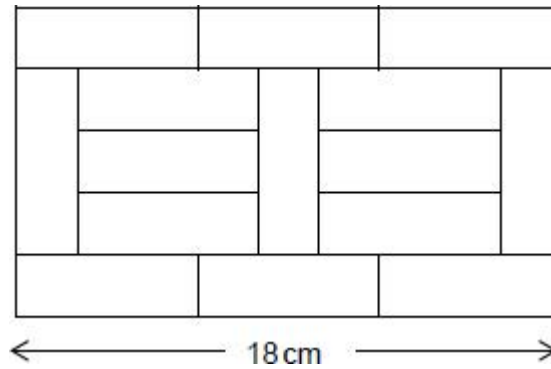

Not drawn accurately

Work out the area of the shape.

Answer _____ cm²
(Total 4 marks)

Q5.

The diagram shows a rectangle.



Not drawn accurately

The rectangle is cut in half with one half thrown away.

This is repeated a second time.

What is the area of the remaining piece?

Answer _____ cm²
(Total 3 marks)

Q6.

Work out the area of this triangle.

Not drawn accurately

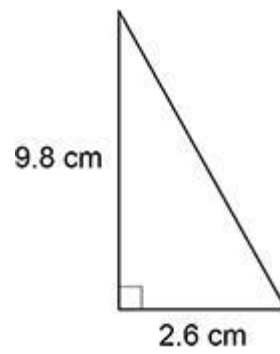

Answer _____ cm²

(Total 2 marks)

Q7.

Here is a shape made from rectangles.

Not drawn accurately

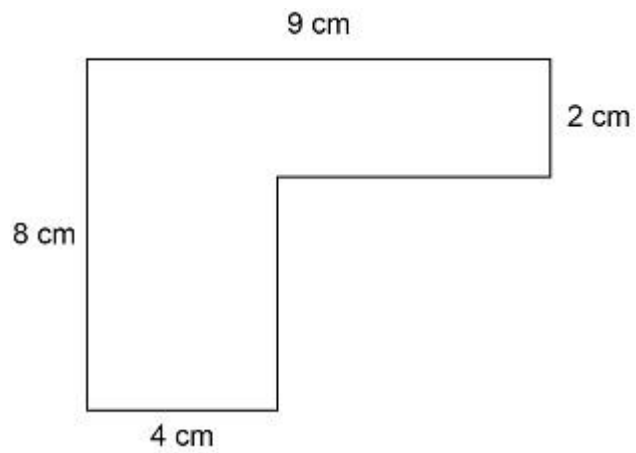

Work out the area.

Answer _____ cm²

(Total 3 marks)

Q8.

Zak wants to work out the area of this triangle.

Not drawn accurately

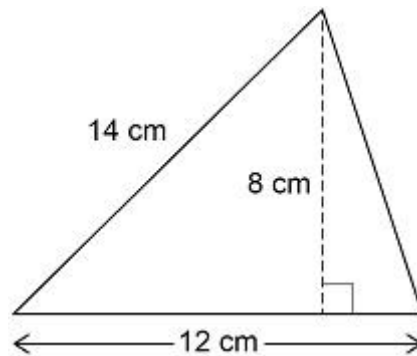

Here is his working.

$12 \times 8 = 96 \text{ cm}^2$

What is wrong with his method?

(Total 1 mark)

Q9.

Each shape below has an area of 24 cm^2

Complete the missing lengths.

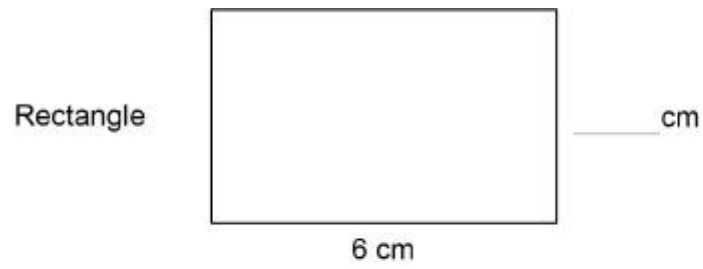

Not drawn accurately

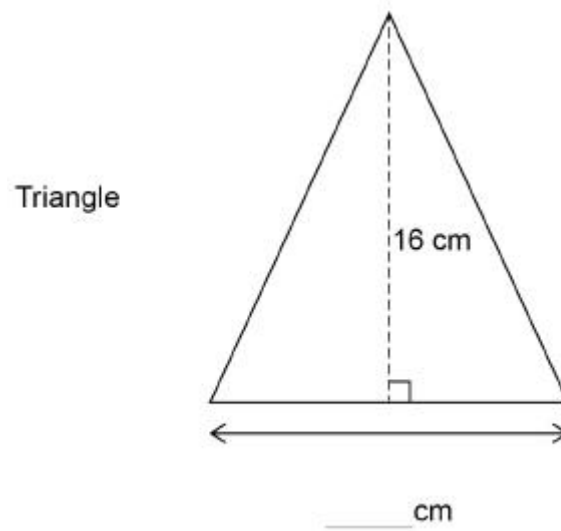

(Total 3 marks)

Q10.

Three identical isosceles triangles are joined to make this trapezium.
Each triangle has base b cm and perpendicular height h cm

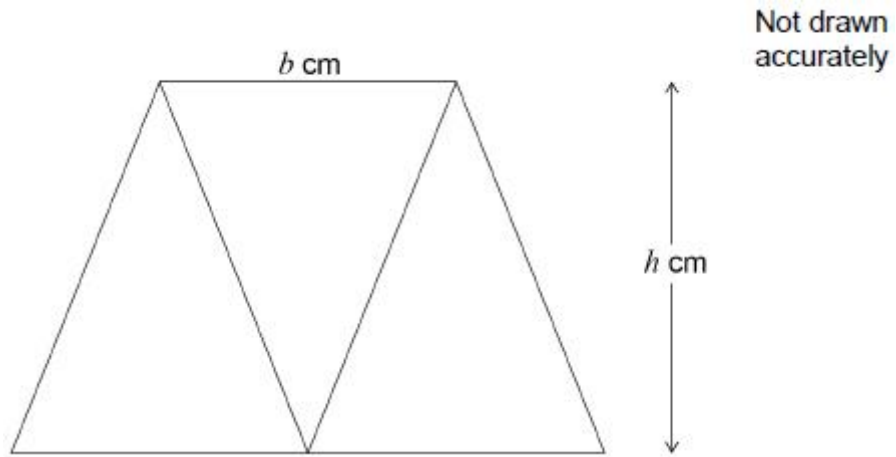

- (a) Work out an expression, in terms of b and h , for the area of the trapezium.
Give your answer in its simplest form.

Answer _____ cm²

(2)

- (b) This diagram shows the same trapezium.

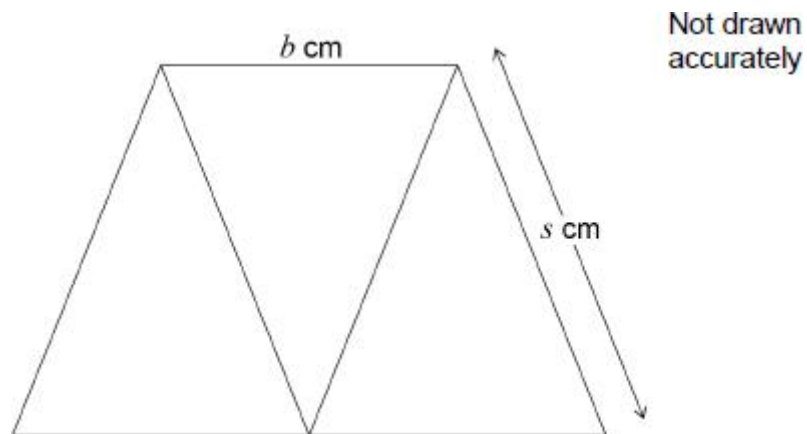

$b : s = 2 : 3$

Work out an expression, in terms of b , for the perimeter of the trapezium.

Answer _____ cm

(2)
(Total 4 marks)

Q11.

(a)

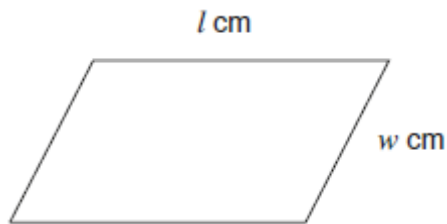

The perimeter of the parallelogram is $P \text{ cm}$

Circle the correct formula.

$P = l + w$

$P = lw$

$P = 2(l + w)$

$P = 2lw$

(1)

(b)

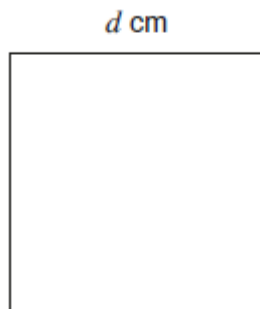

The area of the square is $A \text{ cm}^2$

Circle the correct formula.

$A = 2d$

$A = 4d$

$A = \sqrt{d}$

$A = d^2$

(1)

(c)

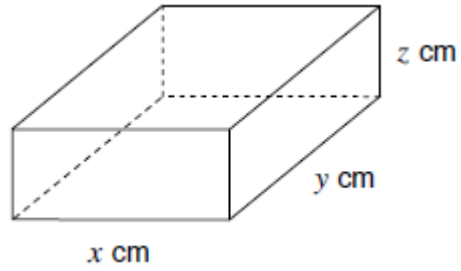

The surface area of the cuboid is $S \text{ cm}^2$

Circle the correct formula.

$S = xyz$

$S = (xyz)^2$

$S = 6xyz$

$S = 2(xy + xz + yz)$

(1)

(d) The surface area of a **cube** is 150 cm^2

Work out the volume of the cube.

Answer _____ cm^2

(4)

(Total 7 marks)

Q12.

Field A is a rectangle with sides of 30 m and 70 m

Field B is a square with the same **perimeter** as Field A.

Not drawn accurately



How much bigger in area is Field B than Field A?
You **must** show your working.

Answer _____ m²

(Total 4

3D Shapes

Q1.

A cube has edges of length 0.7 metres.

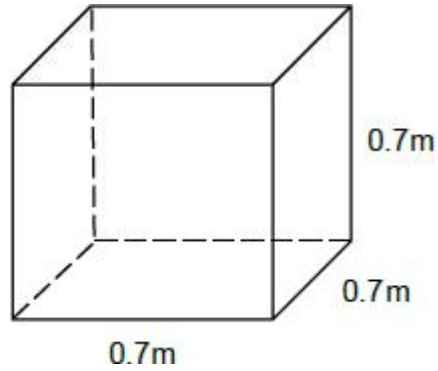

Work out the volume of the cube.

Answer _____ m³
(Total 2 marks)

Q2.

Here is a solid cube.

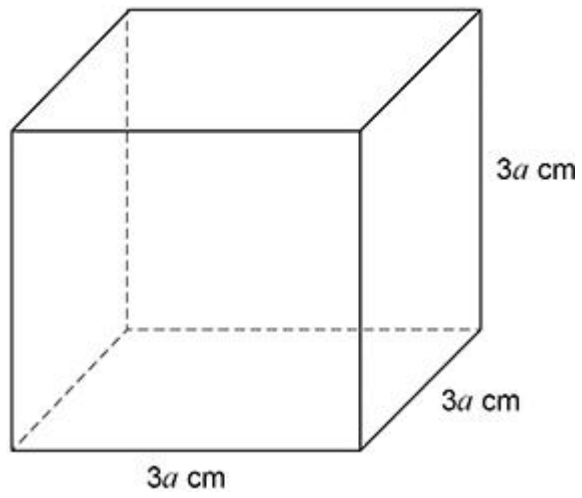

Circle the expression for the **total** surface area in cm^2

$36a$

$54a$

$36a^2$

$54a^2$

(Total 1 mark)

Q3.

Here is a cuboid.

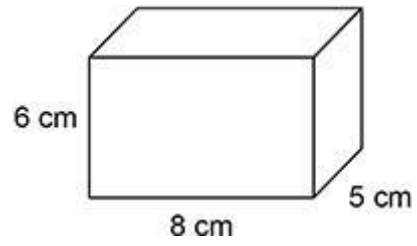

Work out the volume.

Answer _____ cm³
(Total 1 mark)

Q4.

A pyramid has a square base.

Each of the four sloping edges has length 10 cm

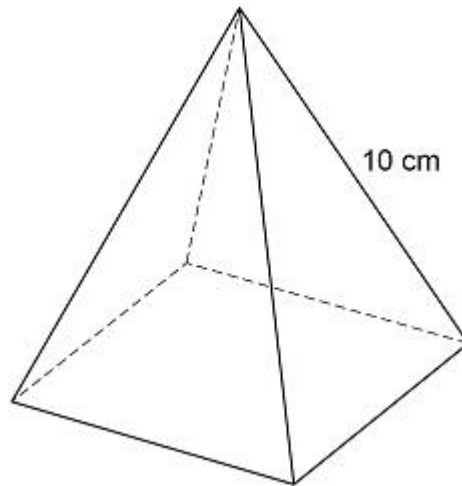

The total length of all eight edges is 68 cm

Work out the **area** of the square base.

Answer _____ cm²

(Total 4 marks)

Q5.

Here is a small cuboid and a cube.

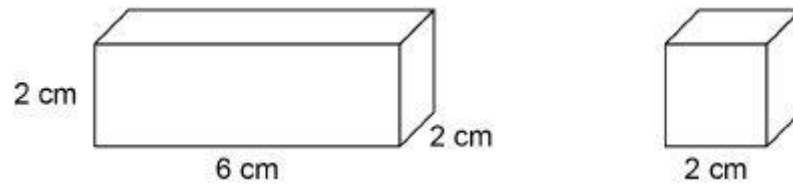

Small cuboids and cubes are stacked in layers to make larger cuboids.

Here is a cuboid made with four layers.

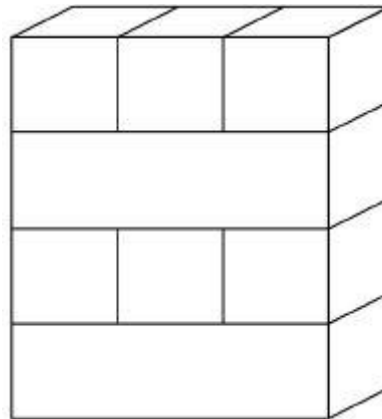

The pattern is continued to make a cuboid with volume 336 cm^3

How many **cubes** are used?

Answer _____

(Total 3 marks)

Q6.

Eva thinks she can save water by having a shower instead of a bath.

Eva's shower

uses 10.8 litres per minute

lasts for 8 minutes.

Eva assumes that the water in her bath is in the shape of this cuboid.

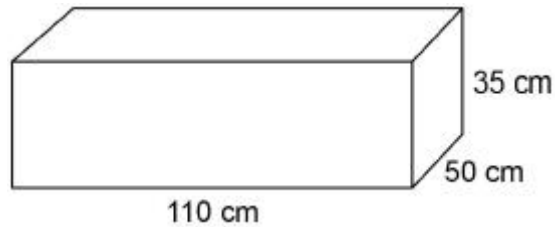

$$1000 \text{ cm}^3 = 1 \text{ litre}$$

- (a) Using Eva's assumption, work out how many litres of water she saves by having a shower instead of a bath.

Answer _____ litres

(5)

- (b) A shows the water level before Eva gets into the bath.

B shows the cuboid in the empty bath.

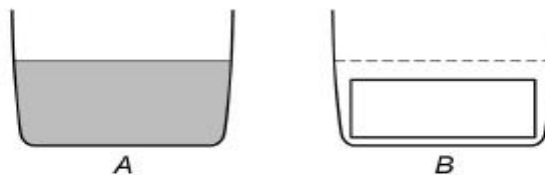

Not drawn accurately

What does this tell you about the amount of water saved?

(1)(Total 6 marks)

Q7.

A cube has edges of length 0.8 metres.

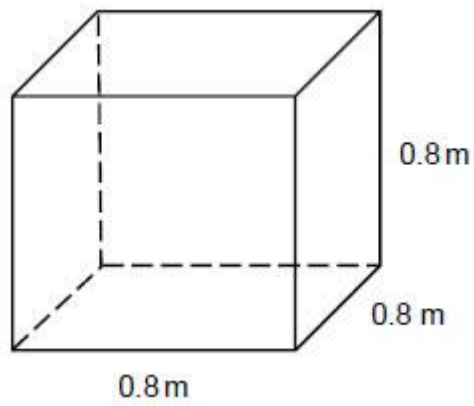

Work out its volume in **cubic centimetres**.

Answer _____ cm³

(Total 2 marks)

Q8.

This triangle is the cross section of a triangular prism of length 10 cm.

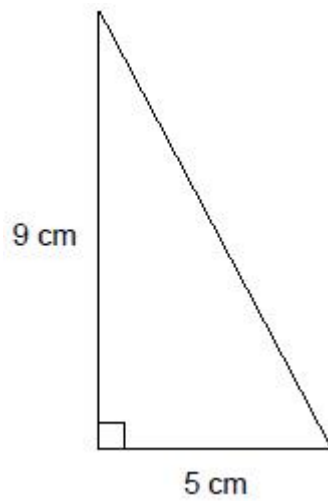

Not drawn accurately

Ali writes,

$$\text{Volume} = 9 \times 5 \times 10$$

$$\text{Volume} = 450 \text{ cm}$$

Check his working and write the correct solution.

(Total 3 marks)

Q10.

The diagram shows a water tank in the shape of a cuboid.

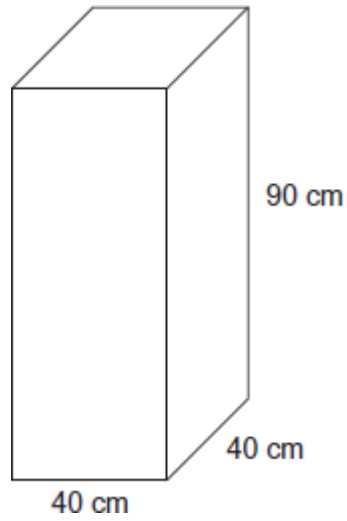

The tank is full of water.

1 litre = 1000 cm³

How many gallons of water are in the tank?

Answer _____ gallons
(Total 4 marks)

Q11.

- (a) How much is 1 gallon in litres?
Circle the closest estimate.

0.7 litres 2.2 litres 2.5 litres 4.5 litres 8.5 litres

(1)

- (b) A fish tank is in the shape of a cuboid measuring 30 cm by 20 cm by 20 cm

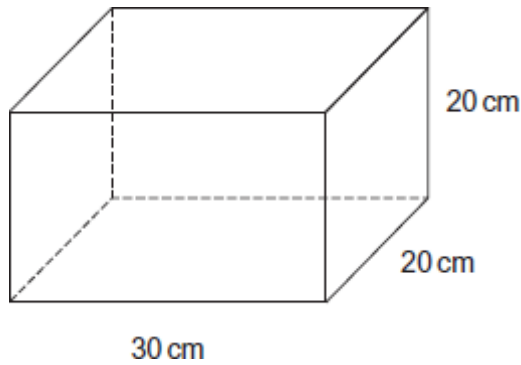

You are given that $1000 \text{ cm}^3 = 1 \text{ litre}$

Can the fish tank hold more than 2 gallons of water?
You **must** show your working.

(3)

(Total 4 marks)

Angles

Q1.

In a triangle, two of the angles are 51° and 74° .

Work out the size of the third angle.

Answer _____ degrees
(Total 1 mark)

Q2.

Here is a triangle.

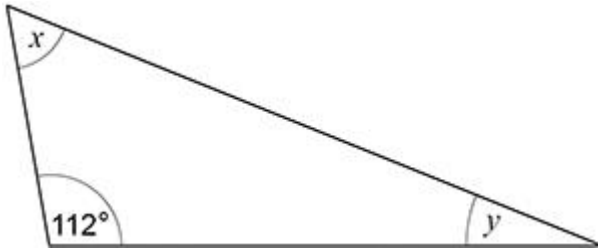

Not drawn
accurately

$$x = 3y$$

Work out the size of angle y .

$y =$ _____ $^\circ$
(Total 3 marks)

Q3.

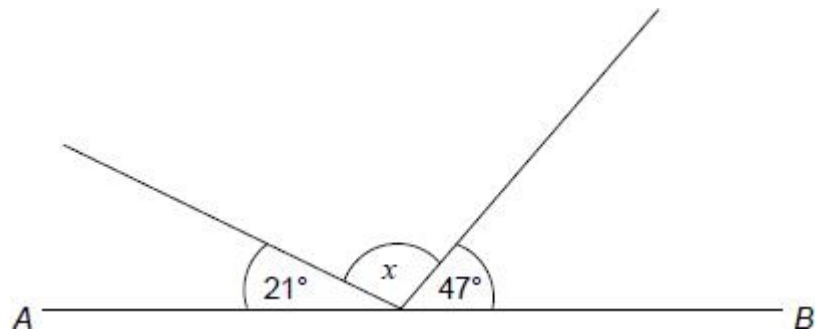

Not drawn accurately

AB is a straight line.

Work out the size of angle x

$$x = \underline{\hspace{4cm}}^\circ$$

(Total 2 marks)

Q4.

In the diagram below, DC is parallel to AB .

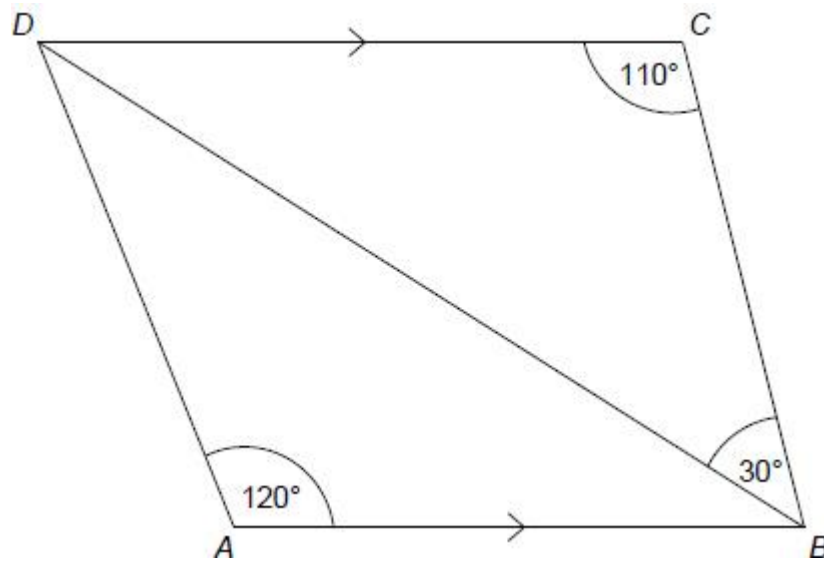

Not drawn accurately

Show that triangle ABD is scalene.

(Total 3 marks)

Q5.

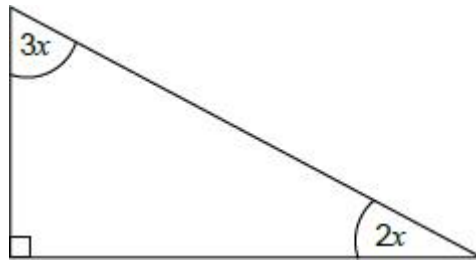

Not drawn accurately

Work out the value of x

$x =$ _____^o

(Total 3 marks)

Q6.

The diagram shows a triangle ACD and an **equilateral** triangle BCD

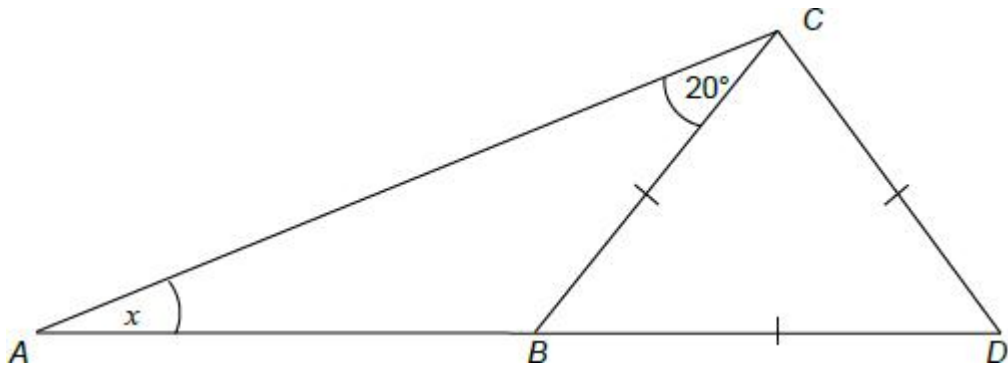

Not drawn accurately

Work out the size of angle x

Answer _____^o

(Total 3 marks)

Q7.

Yan is trying to work out the size of angle x .

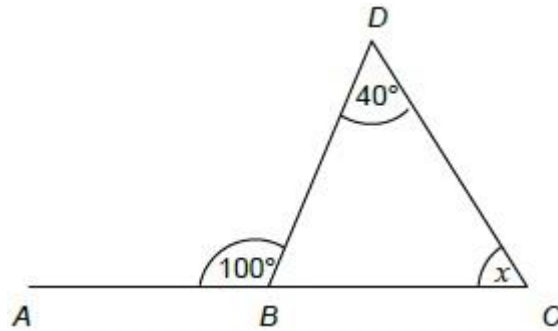

Not drawn accurately

(a) He assumes that ABC is a straight line.

What answer should he get?

Answer _____°

(2)(b) In fact, angle ABC is 178° , as shown.

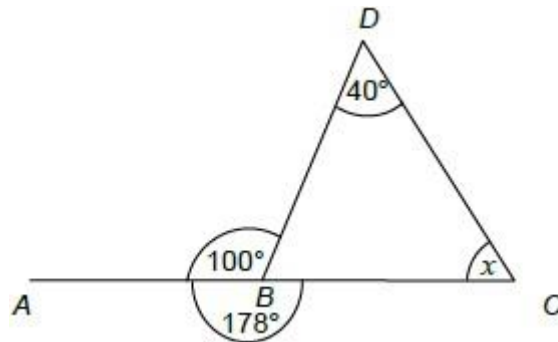

Not drawn accurately

What effect does this have on the size of angle x ?

It is larger than the answer to part (a)

It is the same as the answer to part (a)

It is smaller than the answer to part (a)

(1)(Total 3 marks)

Q8.

The angles in triangle *A* are in the ratio 1 : 2 : 5

The angles in triangle *B* are in the ratio 3 : 4 : 5

Not drawn accurately

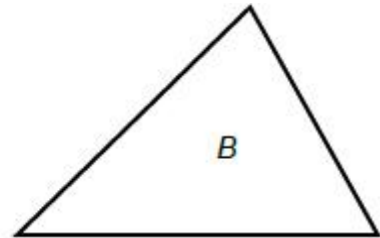
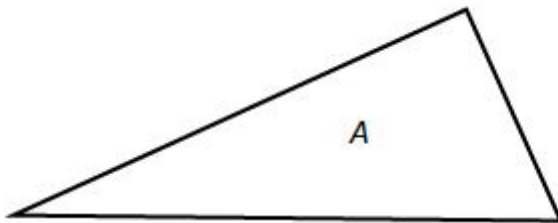

Anisha says,

“The end number in each ratio is 5, so the biggest angle in each triangle must be equal.”

Is she correct?

Yes

No

Show working to support your answer.

(Total 2 marks)

Q9.

ACE and BCD are straight lines.

$AC = BC$

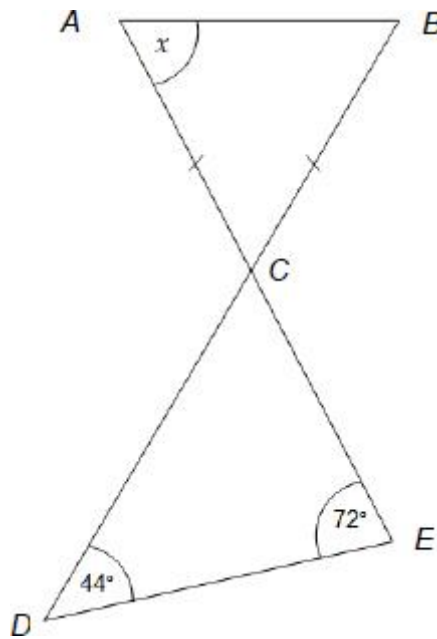

Work out the size of angle x

Answer _____^o
(Total 3 marks)

Q10.

One side of a triangle is extended.

Not drawn accurately

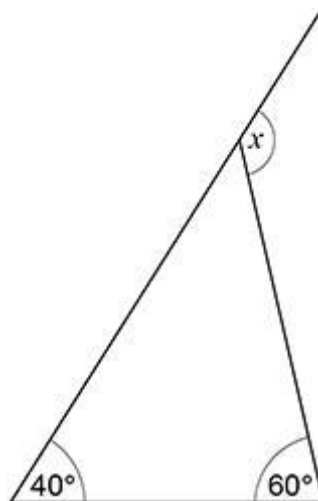

Circle the size of angle x .

100°

80°

60°

40°

(Total 1 mark)

Q11.

Not drawn accurately

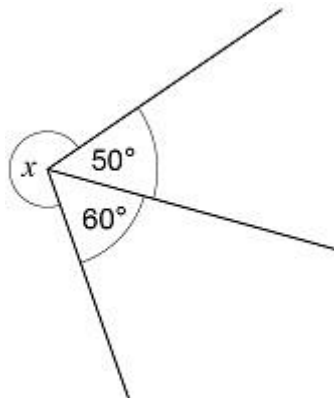

Circle the size of angle x .

70°

110°

250°

270°

(Total 1 mark)

Q12.

AB is a straight line.

Not drawn accurately

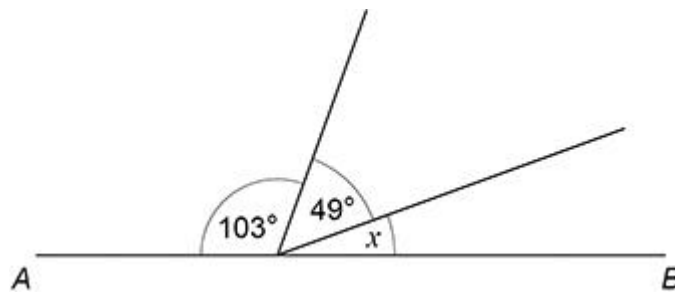

Work out the size of angle x .

Answer _____ degrees
(Total 2 marks)

Q13.

ADB and CD are straight lines.

Not drawn accurately

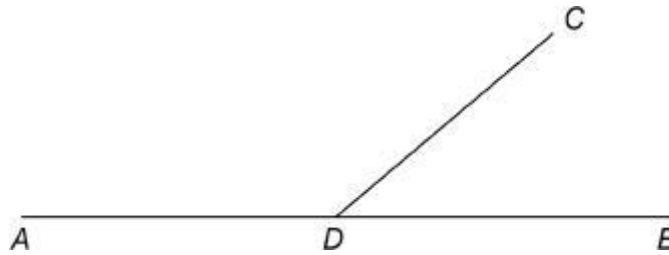

angle $ADC = 5 \times$ angle CDB

Work out the size of angle ADC .

Answer _____ degrees
(Total 3 marks)

Q14.

A straight line passes through two parallel lines.

Not drawn accurately

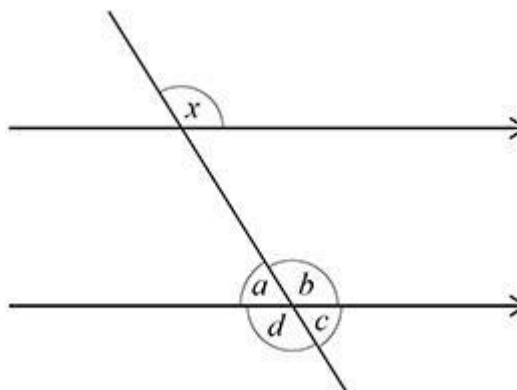

Circle the angle that is **corresponding** to angle x .

a b c d

(Total 1 mark)

Q15.

AB is parallel to *CD*.

FG is a straight line.

Not drawn accurately

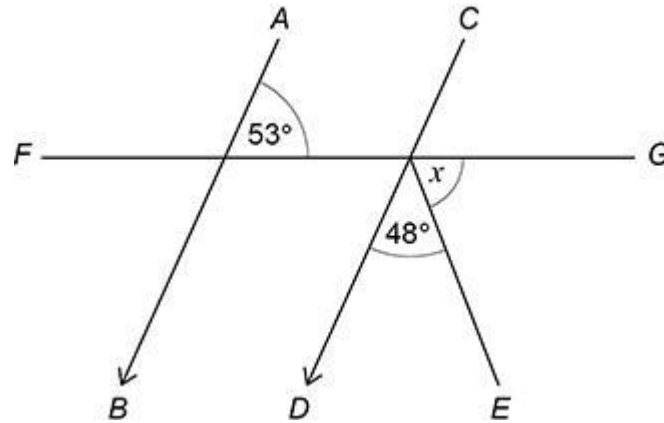

Work out the size of angle x .

Answer _____ degrees
(Total 3 marks)

Q16.

Here are two straight lines.

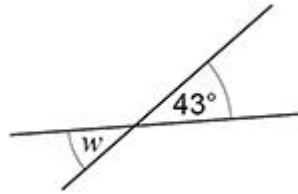

Not drawn accurately

Write down the size of angle w .

$w =$ _____ degrees
(Total 1 mark)

Q17.

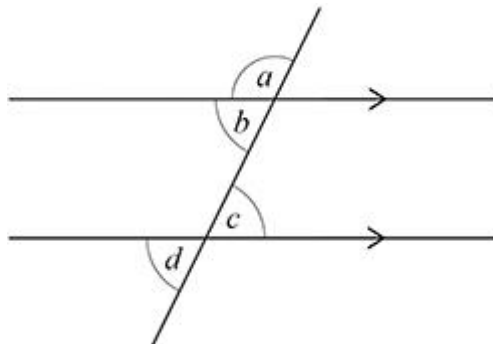

Circle the pair of alternate angles.

a and b

b and c

c and d

a and d

(Total 1 mark)

Angles in Polygons

Q1.

A regular pentagon is drawn below.

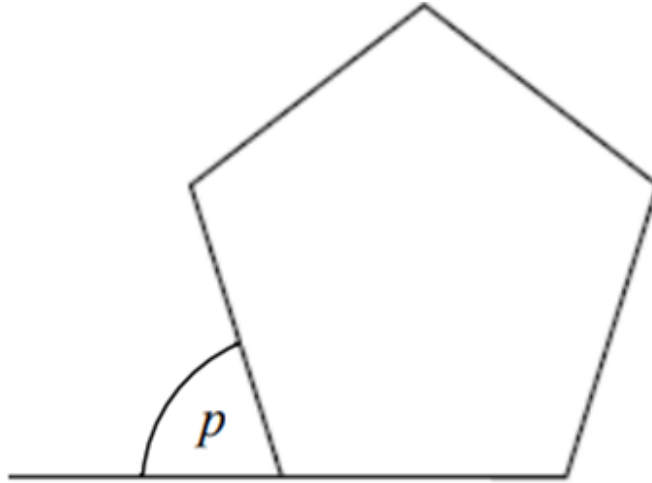

Work out the size of the exterior angle p

$P =$ _____

[2 marks]

Q.2

A regular Octagon is drawn below.

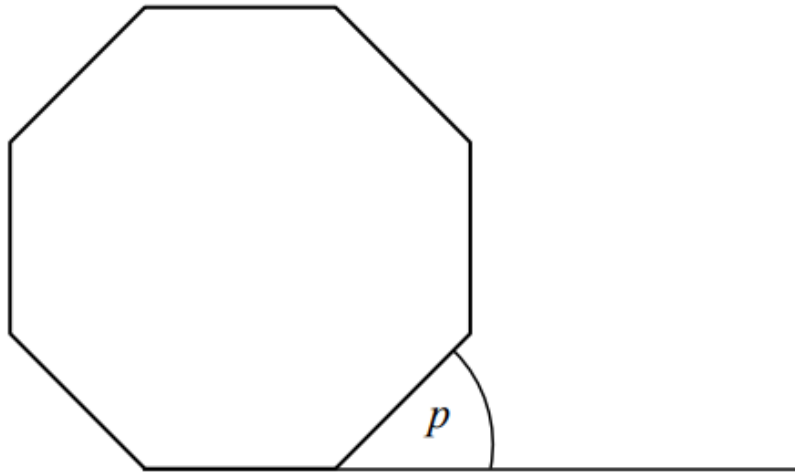

Work out the size of the exterior angle p

$P =$ _____

[2 marks]

Q.3

A regular polygon is drawn below.

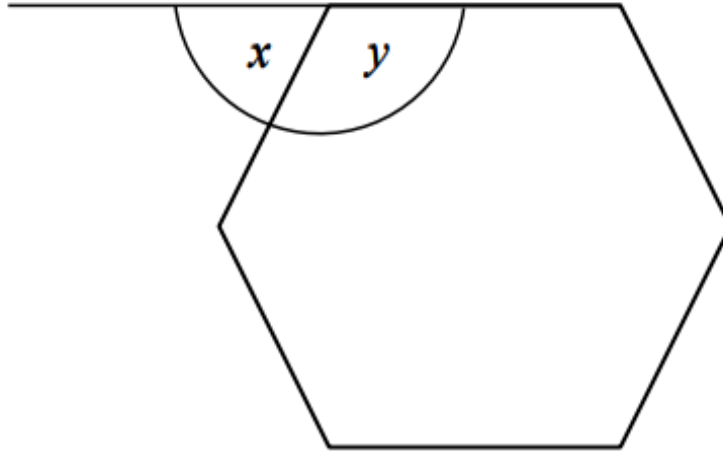

Work out the size of the exterior angle x

$X =$ _____

[2 marks]

Work out the size of the interior angle y

$Y =$ _____

(2 marks)

Q.4

Part of a polygon with 18 sides is shown.

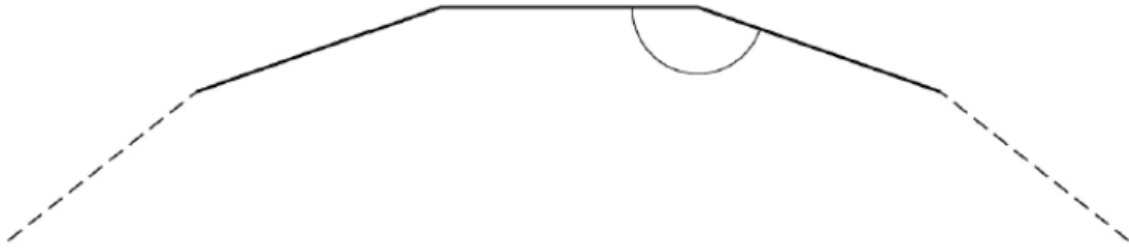

Work out the size of the interior angle

angle = _____

(2 marks)

Q.5

A regular polygon has 12 sides. Work out the size of one interior angle.

(2 marks)

Probability

Q1.

There are 10 discs in a bag.

5 are red, 3 are green and the rest are blue

A counter is chosen at random.

Work out the probability that it is blue.

Answer _____

(Total 2 marks)

Q2.

Write down the probability of rolling a 5 on an ordinary fair dice.

Give your answer as a fraction.

Answer _____

(Total 1 mark)

Q3.

Here are three events for an ordinary fair dice.

- A Roll an odd number
- B Roll a number greater than 6
- C Roll a 3

Draw and label arrows to show the probabilities of events B and C on the probability scale.

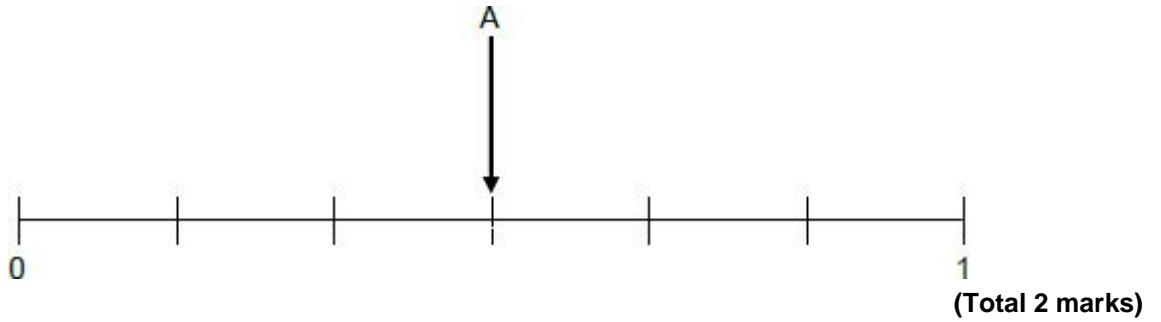

Q4.

Here is a fair 6-sided spinner.

One section is red (R), two sections are yellow (Y), and three sections are white (W).

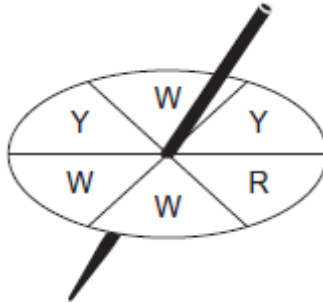

Five probabilities are shown on this probability scale.

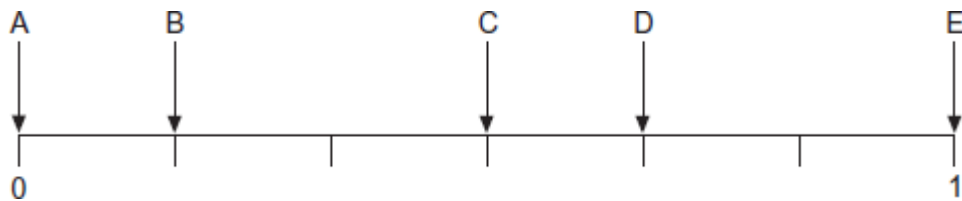

(a) Circle the letter that matches each of these events.

(i) The spinner lands on red.

A B C D E

(1)

(ii) The spinner lands on white.

A B C D E

(1)

(iii) The spinner does **not** land on yellow.

A B C D E

(1)

(iv) The spinner lands on purple.

A B C D E

(1)

(b) The spinner is used in a game.

Red scores 5 points.
Yellow scores 2 points.
White scores 1 point.

Raj and Ben each have 10 spins.
The person with the most points wins the game.

Raj scores 22 points.

The table shows the results for Ben.

Colour	Frequency
Red	3
Yellow	1
White	6

Who wins the game?
You **must** show your working.

Answer _____

(3)
(Total 7 marks)

Q5.

The table shows information about how 150 students travel to school.

	Walk	Bus	Car	
Girls	22	33	17	Total = 72
Boys	24	41	13	Total = 78

- (a) What fraction of the **girls** walk to school?

Give your answer in its simplest form.

Answer _____

(2)

- (b) One of the **boys** is chosen at random.

What is the probability that the boy travels to school by bus?

Answer _____

(1)

- (c) What percentage of the 150 **students** travel to school by car?

Answer _____ %

(2)

(Total 5 marks)

Q6.

An ordinary fair dice is rolled.

$$P(A) = \frac{5}{6}$$

Which could be a correct statement about event A?

Tick **one** box.

The number rolled is even

The number rolled is greater than 1

The number rolled is less than 5

The number rolled is prime

(Total 1 mark)

Q7.

There are 30 passengers on a bus.
13 of them are **male**.

At the next stop 8 people get off the bus and nobody gets on.

The probability that a passenger, picked at random, is **male** is now $\frac{1}{2}$

How many of the people who got off the bus were **female**?

Answer _____

(Total 3 marks)

Q8.

Two bags, A and B, contain numbered counters.

(a) Here are the 8 counters in bag A.

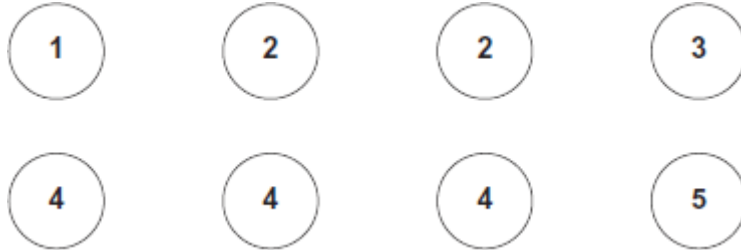

A counter is chosen at random from bag A.

Write down the probability that the number on the counter is 4

Answer _____

(1)

(b) A counter is chosen at random from bag B.

The table gives the probabilities of the numbers on the counters in bag B.

Number on counter	6	7	8	9
Probability	0.2	0.1	0.4	0.3

Which bag has the greater probability of choosing an **even** number?
You **must** show your working.

Answer _____

(2)

(Total 3 marks)

Q9.



At a lucky dip stall, players pick a ball at random from a tub and then **replace it**.

The tub contains 180 red balls
 170 yellow balls
 50 blue balls.

Caroline has a go at the lucky dip.

(a) What is the probability that Caroline wins a prize with her first pick?

Answer _____

(2)

(b) Caroline has 16 goes on the lucky dip and wins 3 prizes.

Is this **more** than the expected number?

You **must** show your working.

Answer _____

(2)

(Total 4 marks)

Q10.

Here is an ordinary dice.



(c) Shenki iStock

- (a) Ali is going to throw the dice six times.

He says,

“I will get one of each number.”

Give a reason why he could be wrong.

(1)

- (b) Lucy throws the dice 50 times.
Her results are shown.

Number thrown	1	2	3	4	5	6
Frequency	7	4	12	5	9	13

Work out the relative frequency of throwing an odd number.

Answer _____

(2)

(Total 3 marks)

Q11.

Boxes A, B, C and D contain balls with numbers on them.

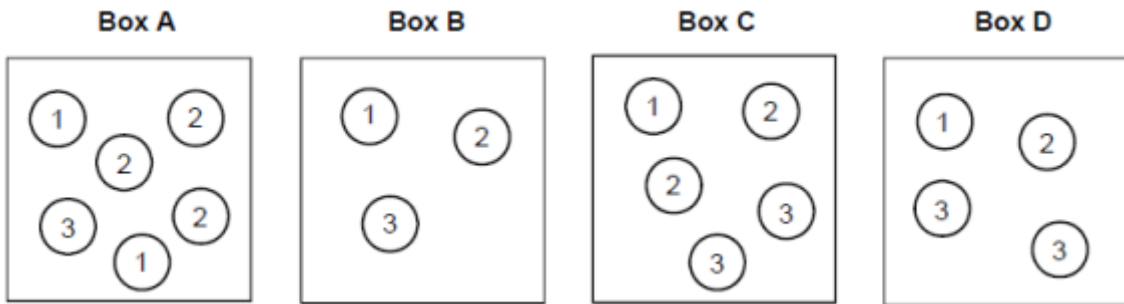

A ball is picked at random from each box.

- (a) Which box gives the **greatest** chance of picking a 3?

You **must** show your working.

Box _____

(2)

- (b) Which two boxes give the **same** chance of picking a 1?

Box _____ and Box _____

(1)

(Total 3 marks)

Q12.

A bag has only red, white, blue and yellow counters.

A counter is taken from the bag at random.

Here are some of the probabilities.

Colour	Red	White	Blue	Yellow
Probability	0.1		0.3	

- (a) The probability of taking a white counter is twice the probability of taking a yellow counter.

Complete the table.

(2)

- (b) There are 500 counters in the bag altogether.

Complete the table.

Colour	Red	White	Blue	Yellow	Total
Number of counters in the bag	50				500

(2)

- (c) All of the yellow counters are taken out of the bag.

Work out the probability of taking a red counter at random from the bag now.

Answer _____

(2)

(Total 6 marks)

Q13.

A bag contains only red counters and blue counters.
There are 6 **more** red than blue.

A counter is chosen at random from the bag.

The probability it is blue is $\frac{1}{4}$

How many **red** counters are in the bag?

Answer _____

(Total 3 marks)

Q14.

Here is a fair spinner with equal-sized sections.

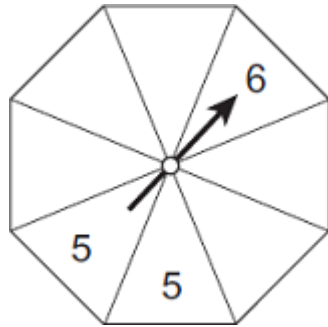

Fill in the missing numbers on the spinner so that
the arrow is equally likely to land on 4 or 5
and the arrow is more likely to land on 3 than 6
and the total of all sections is 32.

(Total 3 marks)

Q15.

Put these probabilities in order, starting with the **least** likely.

72%

0.705

$\frac{7}{10}$

Answer _____ , _____ , _____

(Total 2 marks)

Q16.

Rosie makes phone calls to try to sell broadband.

Today, she made 120 calls.

The table shows the results.

Result of call	Frequency
Not answered	33
Answered but sale not made	81
Answered and sale made	6

(a) Write down the relative frequency that a call was **not answered**.

Answer _____

(1)

(b) During the **rest of the week**, Rosie will make 500 calls.

Using the results in the table, how many sales does she expect to make during the **rest of the week**?

Answer _____

(2)

(Total 3 marks)

Q17.

In a bag there are only red discs, blue discs and green discs.
There are 10 red discs.

When one disc is picked at random

$$P(\text{red}) = \frac{1}{8}$$

$$P(\text{blue}) = \frac{2}{5}$$

How many **green** discs are in the bag?

Answer _____

(Total 4 marks)

Q18.

- (a) Which of these values could represent a probability?
Circle your answer.

-0.2

1.1

0.8

$\frac{6}{5}$

(1)

- (b) A fair ordinary dice is rolled once.
Circle the probability of rolling a 3 or a 4

$\frac{1}{6}$

$\frac{2}{6}$

$\frac{3}{6}$

$\frac{4}{6}$

(1)

(Total 2 marks)

Q19.

On three days, Ali throws darts at a target.

Here are his results.

	Number of throws	Number of hits	Number of misses
Monday	20	15	5
Tuesday	30	22	8
Wednesday	40	17	23
Total	90	54	36

- (a) Work out **two** different estimates for the probability of Ali hitting the target.

Answer _____ and _____

(2)

(b) Which of your two answers is the better estimate for the probability of Ali hitting the target?

Give a reason for your answer.

Answer

Reason

(1)

(Total 3 marks)

Averages

Q1.

For a set of five numbers,

the mode is 8

the median is 12

Work out **one** possible set of five numbers.

Answer _____

(Total 2 marks)

Q2.

A school play takes place each day from Monday to Friday.
Here are the attendances on four of the days.

Monday	Tuesday	Wednesday	Thursday
72	83	88	97

For all **five** days, the mean attendance is 90

Work out the attendance on Friday.

Answer _____

(Total 3 marks)

Q3.

Here is a list of numbers

7 4 9 10 4 3 5 8

(a) Write down the mode.

Answer _____

(1)

(b) Work out the mean.

Answer _____

(2)

(Total 3 marks)

Q4.

Here is a list of numbers:

3 4 4 5 6 7 8 11

(a) Work out the mode.

Answer _____

(1)

(b) Work out the mean.

Answer _____

(2)

(Total 3 marks)

Q5.

Here is a list of numbers.

3 2 6 4 9 1

Work out the median value.

Answer _____

(Total 2 marks)

Q6.

In a band with 3 members, the mean age is 21 years old.

Ashley joins the band.

The mean age of **all** 4 members of the band is now 22 years old.

Work out the age of Ashley.

Answer _____ years old
(Total 4 marks)

Q7.

A company sells bags of toffees and bags of mints.

Here are the numbers of sweets in 11 bags of toffees.

55 50 49 51 55 47 54 50 49 55 57

Here are the numbers of sweets in 10 bags of mints.

46 47 47 48 48 50 53 54 54 54

The company claims that the average number of sweets per bag is at least 50

Using medians, is the company's claim correct for each type of sweet?

You **must** work out the median for toffees and the median for mints.

Toffees _____

Tick a box for toffees.

Yes

No

Mints _____

Tick a box for mints.

Yes

No

(Total 4 marks)

Q8.

Six positive numbers have
a mean of 10
a range of 19

Four of the numbers are 12 7 15 3

Work out the other two numbers.

Answer _____ and _____

(Total 3 marks)

Q9.

Alex and Bev sat six tests, each with 50 marks.

The table shows their mean percentages after five tests.

Alex	60%
Bev	52%

After all six tests, their mean percentages were equal.

In the sixth test, Alex scored 24 out of 50

Work out Bev's score, out of 50, in the sixth test.

Answer _____ out of 50
(Total 4 marks)

Q10.

The table shows the number of films watched one week by 30 people.

Number of films	Frequency	
0	5	
1	9	
2	8	
3	6	
4	2	

Total = 30

(a) Write down the modal number of films watched.

Answer _____

(1)

(b) Work out the mean number of films watched per person.

Answer _____

(3)

(Total 4 marks)

Q11.

Here is some information about 26 houses.

a , b and c are all **different** numbers.

Number of bedrooms	Number of houses
1	7
2	a
3	b
4	c
5	8

The median number of bedrooms is 3.5

Work out a possible set of values for a , b and c .

$a =$ _____

$b =$ _____

$c =$ _____

(Total 3 marks)

Q12.

Here is some information about the members of clubs A and B.

	Number of members	Mean height of members
Club A	24	1.8 m
Club B	20	1.92 m

Work out $\frac{\text{total height of the members of club A}}{\text{total height of the members of club B}}$

Give your answer as a decimal.

Answer _____

(Total 2 marks)

Q13.

A record was kept of the number of days that 25 students were absent one term.
The chart represents the results.

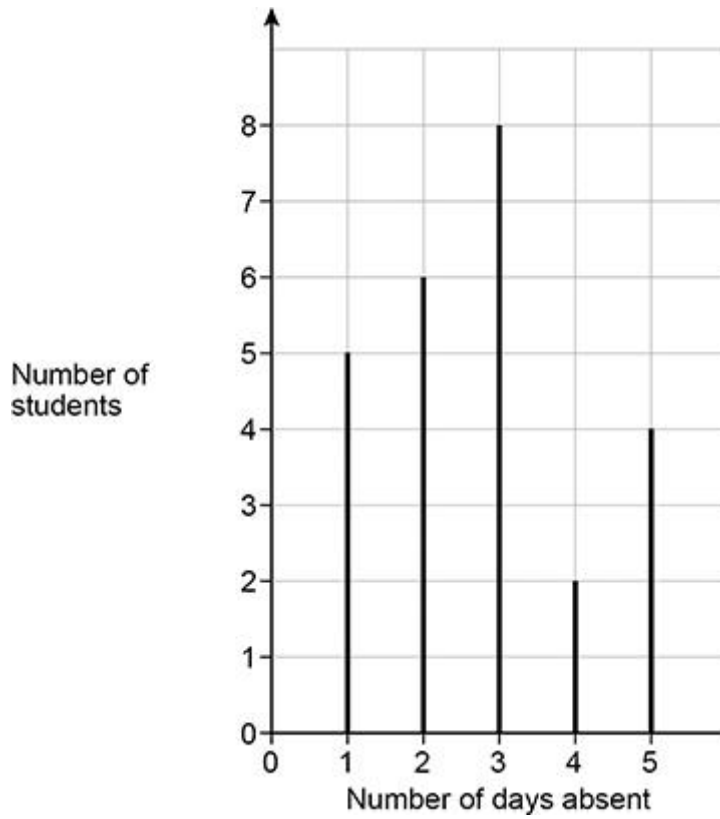

(a) Work out the mean number of days absent.

Answer _____

(3)

(b) One of the students is chosen at random.

Work out the probability that the student was absent for **less than** 4 days.

Answer _____

(2)

(Total 5 marks)

Q14.

A game is played 50 times.

The vertical line chart shows the winning scores.

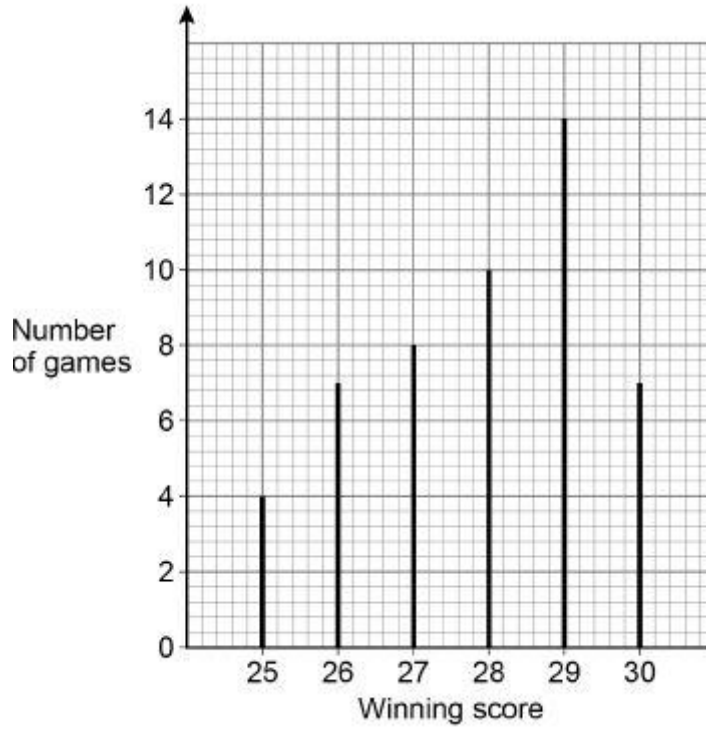

(a) Write down the mode.

Answer _____

(1)

The game is played again.

(b) Use the chart to estimate the probability that the winning score is 25.

Answer _____

(1)

(c) Use the chart to estimate the probability that the winning score is 27 or more.

Answer _____

(2)

(Total 4 marks)

Q15.

Here is some information about the time spent on social media by 40 women and 40 men last week.

Time spent, t (hours)	Number of women	Number of men
$2 < t \leq 5$	12	10
$5 < t \leq 8$	11	17
$8 < t \leq 11$	14	9
$11 < t \leq 14$	2	4
$14 < t \leq 17$	1	0

Tick **one** box for each statement.

	Definitely true	Might be true	Cannot be true
Three of the women spent more than 11 hours on social media.	<input type="checkbox"/>	<input type="checkbox"/>	<input type="checkbox"/>
The range for the men is 15 hours.	<input type="checkbox"/>	<input type="checkbox"/>	<input type="checkbox"/>
The women have a higher median than the men.	<input type="checkbox"/>	<input type="checkbox"/>	<input type="checkbox"/>

(Total 3 marks)

Q16.

The times that 60 customers waited at a supermarket checkout are shown.

Time, t (minutes)	Frequency
$0 \leq t < 2$	18
$2 \leq t < 4$	10
$4 \leq t < 6$	16
$6 \leq t < 8$	12
$8 \leq t < 10$	4

- (a) Write down the class interval that contains the median.

Answer _____

(1)

- (b) The manager of the supermarket says,

“Over 90% of our customers wait less than eight minutes.”

Does the data support this statement?

Yes

No

You **must** show your working.

(2)

(Total 3 marks)

Q17.

A 10 km race took place.

Information about the times achieved by women are in the table.

Time (minutes)	Midpoint	Number of women	
$50 \leq m < 60$		1	
$60 \leq m < 80$		6	
$80 \leq x < 100$		13	
		Total = 20	

The mean time achieved by **men** was 81 minutes.

Compare the mean times achieved by men and women.

(Total 4 marks)

Q18.

The table shows information about the times for 100 people to complete a task.

Time, t , (minutes)	Frequency
$0 < t \leq 5$	17
$5 < t \leq 10$	28
$10 < t \leq 15$	33
$15 < t \leq 20$	22

The shortest time was 2 minutes 50 seconds.

- (a) The shortest time was 2 minutes 50 seconds.

Work out the greatest possible range of times.

Answer _____ minutes _____ seconds

(2)

- (b) Jack says,

“The median time is exactly 10 minutes.”

Give a reason why he **must** be incorrect.

(1)

(Total 3 marks)

Indices

Q1.

Croc is simplifying $6n^5 \times 2n^4$

His answer is $8n^{20}$

Identify the **two** mistakes he has made.

Mistake 1 _____

Mistake 2 _____

(Total 2 marks)

Q2.

Lucy wants to simplify $3p^2 \times 5p^7$

She says,

“Add 3 and 5, then add 2 and 7”

Her answer is $8p^9$

Tick a box for each part of her method.

	Correct	Not correct
Add 3 and 5	<input type="checkbox"/>	<input type="checkbox"/>
Add 2 and 7	<input type="checkbox"/>	<input type="checkbox"/>

(Total 1 mark)

Q3.

Match each expression in Column P with the equivalent expression in Column Q.

One has been done for you.

Column P

Column Q

$$a^2 \times a$$

$$6a$$

$$2a \times 3$$

$$5a$$

$$12a^2 \div 2$$

$$a^3$$

$$10 \times \frac{1}{2}a^2$$

$$5a^2$$

$$6a^2$$

(Total 3 marks)

Q4.

Work out $\sqrt{7.5^2 + 18^2}$

Circle your answer.

19.5

25.5

331.5

380.25

(Total 1 mark)

Q5.

Kris is simplifying $3n^5 \times 2n^4$

His answer is $5n^{20}$

Identify any mistakes he has made.

(Total 2 marks)

Q6.

(a) Circle the number that is an integer power of 4

2

8

16

32

(1)

(b) Work out $5^{12} \div 5^3 \times 5^2$ as a power of 5
Circle your answer.

5^6

5^8

5^9

5^{11}

(1)

(Total 2 marks)

Q7.

(a) Work out the value of $3^3 + 4^2$

Answer _____

(2)

(b) Work out $5^3 - 10^2$

Give your answer as a power of 5.

Answer _____

(3)

(Total 5 marks)

Q8.

k is a whole number between 40 and 50

The cube root of k is 3, to the nearest whole number.

Work out the **largest** possible value of k .

Answer _____

(Total 2 marks)

Q9.

Work out $2.8^4 + \sqrt{158.76}$

Give your answer as a decimal.

Answer _____

(Total 2 marks)

Standard Form

Q1.

What is 1.8×10^{-4} as an ordinary number?

Circle your answer.

-180 000

-18 000

0.000 18

0.000 018

(Total 1 mark)

Q2.

Work out $80\,000\,000 \div 200$

Give your answer in standard form.

Answer _____

(Total 2 marks)

Q3.

Work out the value of 300^2

Give your answer in standard form.

(Total 2 marks)

Q4.

Write 61.6×10^3 in standard form.

Answer _____

(Total 1 mark)

Q5.

Write 0.000 046 in standard form

Answer _____

(Total 1 mark)

Q6.

(a) Write 0.0078 in standard form.

Answer _____

(2)

(b) Work out $(7.68 \times 10^9) \div (3.2 \times 10^4)$

Give your answer in standard form.

Answer _____

(2)

(Total 4 marks)

Q7.

Write these numbers in ascending order.

9812

9.82×10^2

9.81×10^3

Answer _____

(Total 2 marks)

Q8.

Work out $2000 \times 70\,000$

Give your answer in standard form.

Answer _____

(Total 2 marks)

Q9.

Write $360\,000$ in standard form.

Answer _____

(Total 1 mark)

Q10.

Write 9.2×10^{-3} as an ordinary number.

Answer _____

(Total 1 mark)

Q11.

Circle the number that is written in standard form.

0.9×10^{-3}

$6 \times 10^{0.5}$

5.2×10^{-4}

12×10^7

(Total 1 mark)

Q12.

- (a) Write 0.000 97 in standard form.

Answer _____

(1)

- (b) Work out $\frac{3 \times 10^5}{4 \times 10^3}$

Give your answer as an ordinary number.

Answer _____

(2)

(Total 3 marks)

Q13.

- (a) Work out $\frac{2 \times 10^{14}}{8 \times 10^9}$

Give your answer in standard form.

Answer _____

(2)

(b) $6200.07 = 6.2 \times 10^c + 7 \times 10^d$

Work out the values of c and d .

$c = \underline{\hspace{2cm}}$ $d = \underline{\hspace{2cm}}$

(2)

(Total 4 marks)

Q14.

Circle the number that is in standard form.

0.25×10^4

6×10^7

38×10^{-3}

$4 \times 10^{\frac{1}{2}}$

(Total 1 mark)

Q15.

Work out $\frac{9.12 \times 10^{10}}{3.2 \times 10^4}$

Give your answer in standard form.

Answer $\underline{\hspace{4cm}}$

(Total 2 marks)

Compound Interest

Q1.

The value of a second-hand car is £9000

Each year it loses 20% of its value at the start of that year.

Work out its value in four years time.

Answer £ _____

(Total 3 marks)

Q2.

House prices rise at a rate of 10% each year.

In January 2020, Greta bought a house for £200 000

What is the value of the house in January 2022?

Answer £ _____

(Total 2 marks)

Q3.

Daniel invests £2500 for 3 years.
The compound interest rate is 2.9% per year.

- (a) Which calculation works out the total value after 3 years?
Circle your answer.

$$£2500 \times 1.029 \times 3$$

$$£2500 \times 2.9 \times 3$$

$$£2500 \times 2.9^3$$

$$£2500 \times 1.029^3$$

(1)

- (b) Anna invests £2500 for 3 years.

The interest rate is

3.5% for the first year

2.3% for the second year onwards.

Whose investment is worth more after 3 years?

You **must** show your working.

Answer _____

(4)

(Total 5 marks)

Q4.

£6000 is invested at 2.5% compound interest.

- (a) Show that the value of the investment after 2 years is £6303.75

(2)

- (b) In the third year the interest rate falls to 2.4%
In the fourth year the interest rate falls to 2.35%

Will the interest for year 4 be more or less than the interest for year 3?

Tick a box.

More Less

You **must** show your working.

(4)
(Total 6 marks)

Q5.

Mia wants to borrow £6000 and repay it, with interest, after two years.

She sees two offers for loans.

<p>Offer 1 Compound interest 3% per year</p>

<p>Offer 2 Compound interest First year 1% Second year 5%</p>
--

Mia says,

“I will pay back the same amount because the average of 1% and 5% is 3%”

Is she correct?

You **must** show your working.

(Total 3 marks)

Q6.

The value of a house is £120 000.

The value is expected to increase by 5% each year.

Work out the expected value after 4 years.

Give your answer to 2 significant figures.

You **must** show your working.

Answer £ _____

(Total 4 marks)

Q7.

Investment A Save £150 per month for 2 years.
2.5% interest is added to the total amount saved.

Investment B Invest £3500
Compound interest is added at 3% per year.

After 2 years, how much **more** is investment B worth than investment A?

Answer £ _____

(Total 4 marks)

Q8.

Doug owes an amount of £600

He wants to pay back this amount in five months.

He says,

“Each month, I will pay back 20% of the amount I still owe.”

Show working to check if his method is correct.

(Total 3 marks)

Q9.

The value of a second-hand car is £8000

Each year it loses 20% of its value at the start of that year.

Work out its value in 5 years time.

Answer £ _____

(Total 3 marks)

Q10.

A ball is dropped from a height of 50 metres.
After each bounce, the ball reaches 20% of its previous height.

How high does it reach after the second bounce?

Answer metres
(Total 2 marks)

Q11.

Dev invests £1500 for 2 years.
The compound interest rate is 1.6% per year.

- (a) Which calculation works out the total value after 2 years?
Circle your answer.

$£1500 \times 1.6 \times 2$	$£1500 \times 1.6^2$
$£1500 \times 1.016 \times 2$	$£1500 \times 1.016^2$

(1)

- (b) Emma invests £1500 for 2 years.

The interest rate is
1.8% for the first year
1.3% for the second year.

Whose investment is worth more after 2 years?
You **must** show your working.

Answer _____

(4)

(Total 5 marks)

Q12.

£4000 is invested at 1.5% compound interest.

- (a) Show that the value of the investment after 2 years is £4120.90

(2)

- (b) In the third year the interest rate falls to 1.4%
In the fourth year the interest rate falls to 1.35%

Will the interest for year 4 be more or less than the interest for year 3?
Tick a box.

More

Less

You **must** show your working.

(4)

(Total 6 marks)

Sequences

Q1.

A sequence of patterns uses black squares and white squares.

Here are the first three patterns.

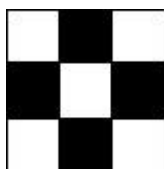

Pattern 1

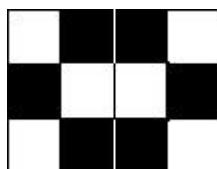

Pattern 2

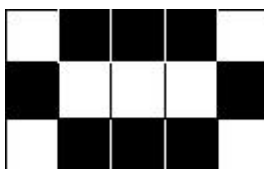

Pattern 3

(a) How many black squares are in Pattern 4?

Answer _____

(1)

(b) Circle the expression for the number of black squares in Pattern n

$4n$

$n + 2$

$6n - 2$

$2n + 2$

(1)

(c) Will the number of black squares always be even?

Tick a box.

Yes

No

Give a reason for your answer.

(1)

(Total 3 marks)

Q2.

The n th term of a sequence is n^2

(a) Work out the value of the 15th term.

Answer _____

(2)

(b) Which term in the sequence is the first one with a value **greater** than 1000 ?

Answer _____

(3)

(Total 5 marks)

Q3.

A linear sequence starts

11 21 31 41 ...

Work out an expression for the n th term of the sequence.

Answer _____

(Total 2 marks)

Q4.

The n th term of a sequence is $19 - 4n$

What is the **smallest** value of n that gives a negative term?

Answer _____

(Total 2 marks)

Q5.

(a) The term-to-term rule for a sequence is

add 4 then divide by 2

The 1st term of the sequence is 36

Work out the 3rd term.

Answer _____

(2)

(b) The term-to-term rule for a different sequence is

divide by 3 then add 10

The 2nd term of this sequence is 60

Work out the 1st term.

Answer _____

(2)

(Total 4 marks)

Q6.

Match each sequence to its description.

One has been done for you.

1 1 2 3 5 8

1 2 4 8 16 32

1 2 3 4 5 6

1 3 6 10 15 21

1 4 9 16 25 36

1 8 27 64 125 216

Arithmetic progression

Geometric progression

Fibonacci sequence

Triangular numbers

Cube numbers

Square numbers

(Total 4 marks)

Q7.

Here is a rule for a sequence.

After the first two terms, each term is half the sum of the previous two terms

(a) Here is a sequence that follows this rule.

2 10 6

Show that the 6th term is the first one that is **not** a whole number.

(3)

(b) A different sequence follows the same rule.

The 1st term is 4

The 3rd term is 9.5

4 9.5

Work out the 2nd term.

Answer _____

(3)

(Total 6 marks)

Q8.

The n th term of a sequence is $12n - 5$

Work out the numbers in the sequence that
have two digits
and
are **not** prime.

Answer £ _____

(Total 3 marks)

Q9.

The n th term of a sequence is $5n - 2$

Work out the 3rd term.

Circle your answer.

51

5

123

13

(Total 1 mark)

Q10.

The first four terms of a linear sequence are

7

11

15

19

Circle the expression for the n th term.

$n + 6$

$4n + 3$

$7n + 4$

$n + 4$

(Total 1 mark)

Q11.

(a) The term-to-term rule of a sequence is

Add 8 and divide by 2

The first term of the sequence is -24

Work out the next two terms.

Answer _____ and _____

(2)

(b) The term-to-term rule of a different sequence is

Subtract 1 and multiply by 5

The third term of this sequence is 120

..... 120

Work out the first term.

Answer _____

(2)

(Total 4 marks)

Q12.

Here are some numbers.

10 13 15 20 27 39

10 15 20 is an arithmetic progression.

Use **three** of the numbers to make a different arithmetic progression.

Describe the rule

Answer _____

Rule _____

(Total 2 marks)

Q13.

A sequence has three terms.

The term-to-term rule for the sequence is

multiply by 8 and then add 11

(a) The first term of the sequence is -1

Work out the third term.

Answer _____

(2)

(b) The order of the three terms is reversed to make a new sequence.

Work out the term-to-term rule for this sequence.

Answer _____

(1)

(Total 3 marks)

Q14.

A sequence of patterns uses black squares and white squares.

Here are the first three patterns.

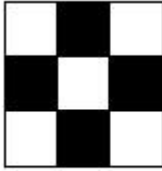

Pattern 1

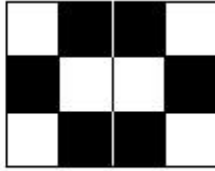

Pattern 2

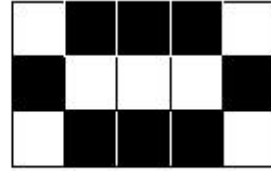

Pattern 3

- (a) Circle the expression for the number of black squares in Pattern n .

$4n$

$n + 2$

$6n - 2$

$2n + 2$

(1)

- (b) Will the number of black squares always be even?

Tick a box.

Yes

No

Give a reason for your answer.

(1)

(Total 2 marks)

Q15.

(a) Here are the fourth and fifth terms of a Fibonacci-type sequence.

..... 28 43

Each term is the sum of the previous two terms.

Show that the first term is 2

(2)

(b) Here are the first and third terms of a different Fibonacci-type sequence.

a b

Each term is the sum of the previous two terms.

Work out an expression in terms of a and b for the fifth term.

Answer _____

(3)

(Total 5 marks)

Q16.

The n th term of a sequence is $3n^2$

- (a) Work out the value of the 15th term.

Answer _____

(2)

- (b) What is the position of the term in the sequence that is the first one with a value greater than 1000?

Answer _____

(3)

(Total 5 marks)

Q17.

- (a) The n th term of a sequence is $6 - 2n$

Work out the first three terms of the sequence.

Answer _____ , _____ , _____

(2)

- (b) Here is the term-to-term rule for a different sequence.

Multiply previous term by 2 and then subtract 3
--

The third term in this sequence is 31

Work out the **first** term.

Answer _____

(3)

(Total 5 marks)

Q18.

(a) Here is a sequence.

5 8 11 14 17

Write down the next number in the sequence.

Write down the rule for continuing the sequence.

Next number _____

Rule _____

(2)

(b) Here is a different sequence.

Work out the n th term of the sequence.

7 13 19 25 31

Answer _____

(2)

(Total 4 marks)

Q19.

A sequence begins 1 6 16

The rule for the sequence is

Double the previous term and add 4

Work out the next **two** terms in the sequence.

Answer _____ and _____

(Total 2 marks)

Q20.

This sequence of patterns is made using sticks.

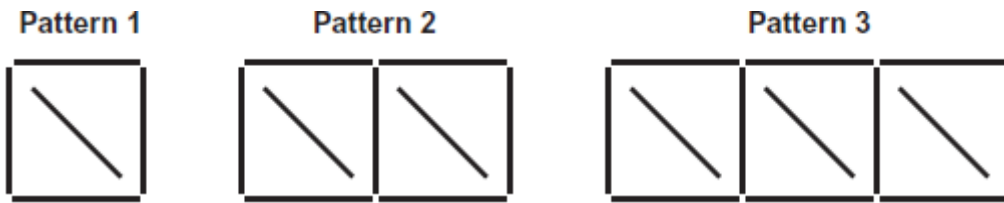

(a) Complete the table for Pattern 4 and Pattern 5

Pattern	1	2	3	4	5
Number of sticks	5	9	13		

(1)

(b) Work out the n th term of the sequence 5 9 13 ...

Answer _____

(2)

(c) Which pattern is made using 53 sticks?

Answer _____

(2)

(Total 5 marks)

Pythagoras

Q1.

Here is a triangle.

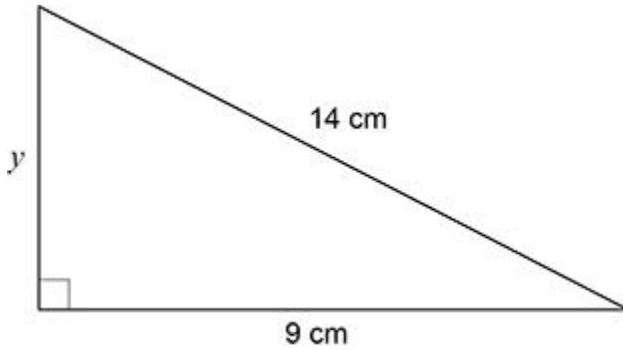

Not drawn
accurately

Use Pythagoras' theorem to work out the value of y .

Give your answer as a decimal.

$y =$ _____ cm
(Total 3 marks)

Q2.

Here is triangle ABC .

Not drawn accurately

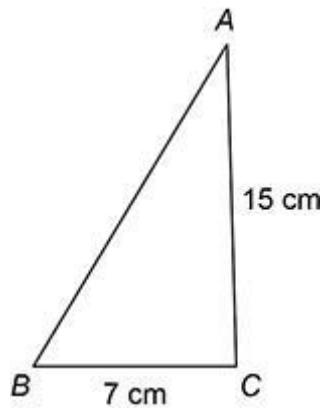

- (a) Assume that angle $ACB = 90^\circ$

Work out the length AB .

Answer _____ cm

(3)

(b) The actual length AB is greater than the answer to part (a).

What does this mean about angle ACB ?

Tick **one** box.

It is 90°

It is less than 90°

It is more than 90°

It could be any of the above.

Q3.

Work out the length of the hypotenuse.

Not drawn accurately

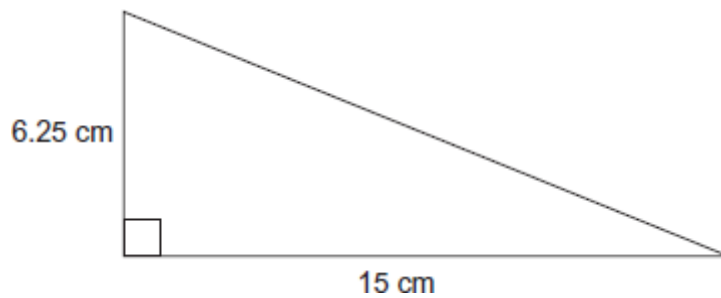

Answer _____ cm

(Total 3 marks)

Q4.

Not drawn accurately

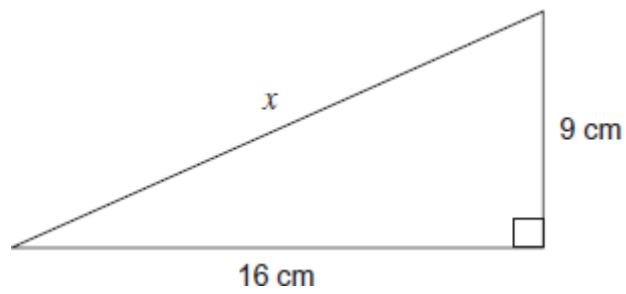

Work out the length x .
Give your answer to 1 decimal place.

Answer _____ cm
(Total 4 marks)

Q5.

Use Pythagoras' theorem to work out the value of x .

Not drawn accurately

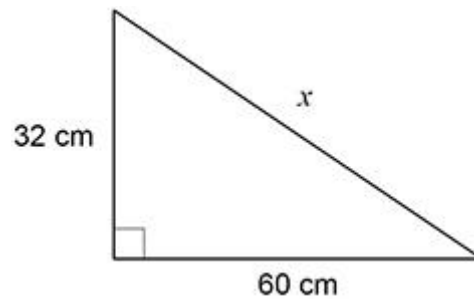

Answer _____ cm

(Total 3 marks)

Q6.

Robin is attempting to work out the base of **several** right-angled triangles.

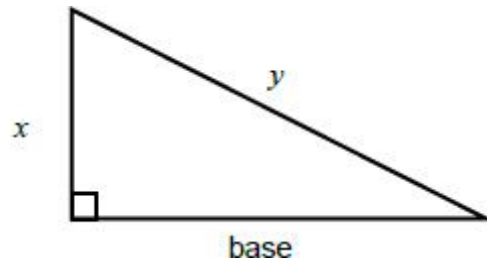

Not drawn accurately

Here is his method with the working for $y = 5$ and $x = 3$

Work out the value of y^2 $5^2 = 25$

Work out the value of x^2 $3^2 = 9$

Work out the value of $y^2 - x^2$ $25 - 9 = 16$

The base is $\sqrt{y^2 - x^2}$ $\text{base} = \sqrt{16}$

Tick the correct statement.

The method will **always** give an answer which is a whole number.

The method will **sometimes** give an answer which is a whole number.

The method will **never** give an answer which is a whole number.

Give examples to support your answer.

(Total 3 marks)

Q7.

Here is a right-angled triangle.

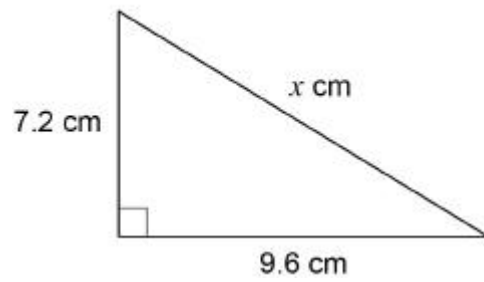

Not drawn
accurately

Show that $x = 12$

(Total 2 marks)

Q8.

The diagram shows rectangle $ABDE$ and right-angled triangle ABC .

$AC = 17 \text{ cm}$

$BC = 8 \text{ cm}$

Not drawn accurately

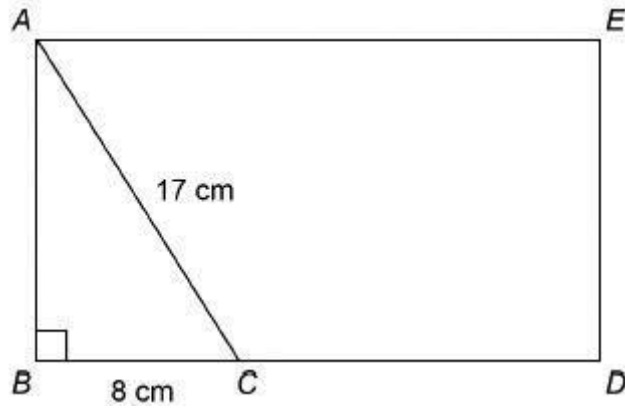

$BC : CD = 1 : 2$

Work out the area of rectangle $ABDE$.

Answer _____ cm^2

(Total 4 marks)

Q9.

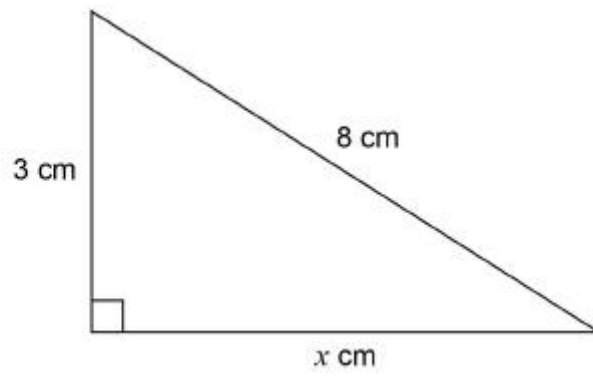

Not drawn accurately

Work out the value of x as a decimal.

Answer _____

(Total 3 marks)

Q10.

In the diagram the area of triangle ABD is 56 cm^2

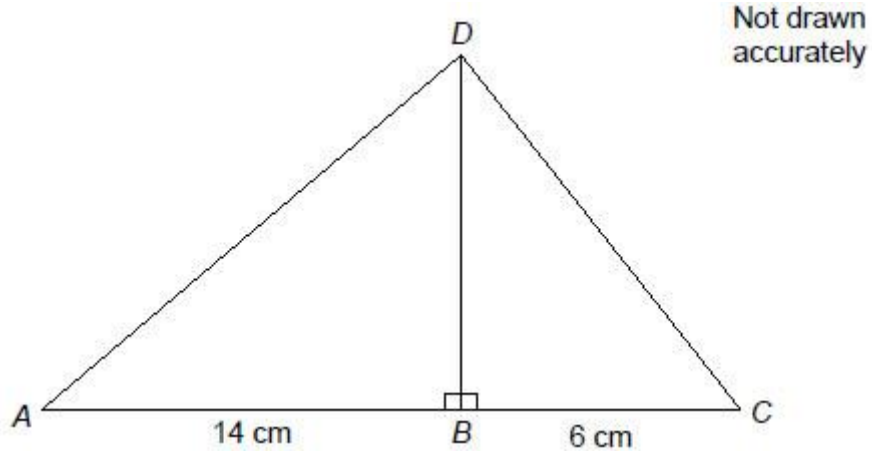

Work out the length of CD .

Answer _____ cm

(Total 4 marks)

Q11.

A circle has diameter 10 cm.
A square has side length 6 cm.

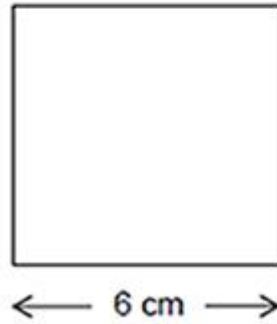
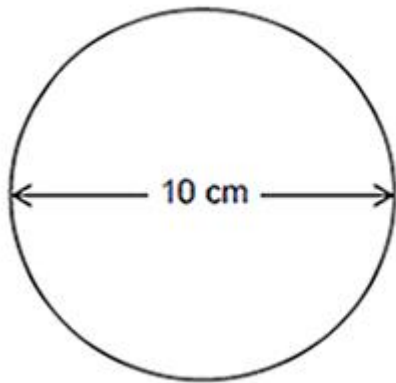

Not drawn
accurately

Use Pythagoras' theorem to show that the square will fit inside the circle without touching the edge of the circle.

(Total 3 marks)

Q12.

E is the centre of rectangle $ABCD$.

Not drawn accurately

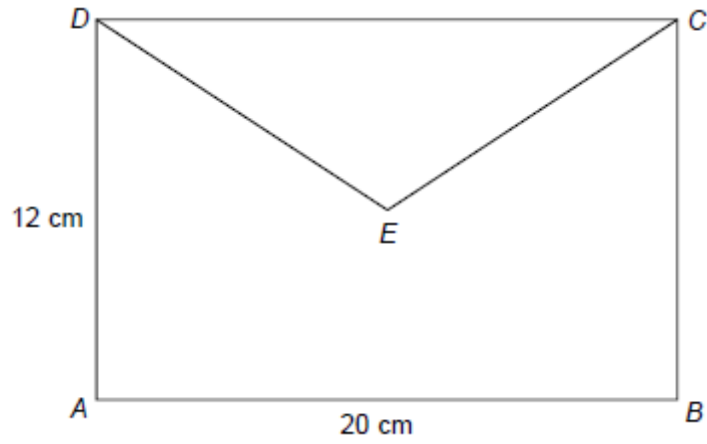

Work out the length DE .

Answer _____ cm

(Total 3 marks)

Q13.

In the diagram the area of triangle ACD is 45 cm^2

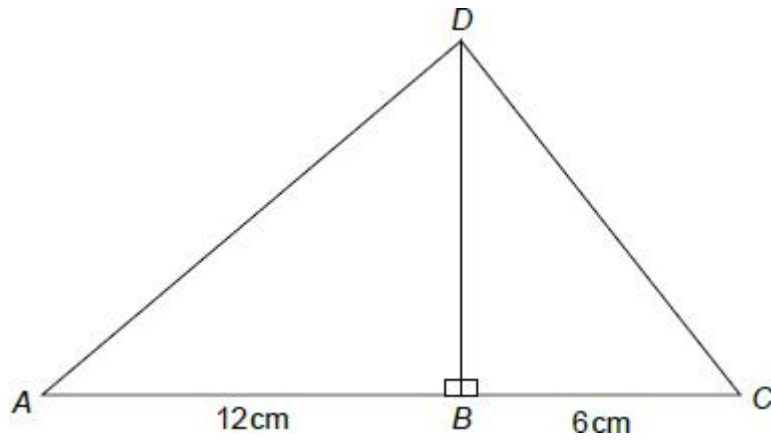

Not drawn accurately

Work out the length of AD .

Answer _____ cm
(Total 4 marks)

Q14.

Not drawn accurately

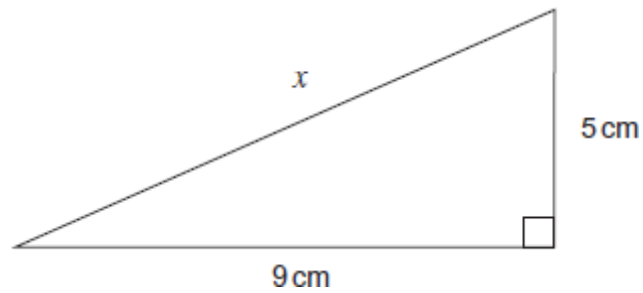

Work out the length x
Give your answer to 1 decimal place.

Answer _____ cm

(Total 4 marks)

Q15.

Not drawn accurately

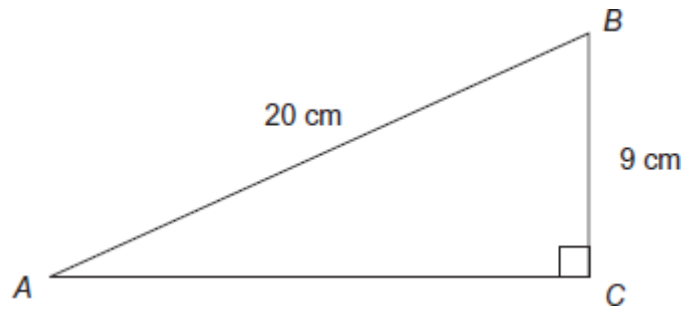

Work out the length AC.
Give your answer to 1 decimal place.

Answer _____ cm

(Total 4 marks)

Frequency Trees

Q1.

480 people are asked if they eat sushi.

20% say Yes.

$\frac{2}{3}$ of the people who say Yes eat sushi at least once a month.

Complete the frequency tree.

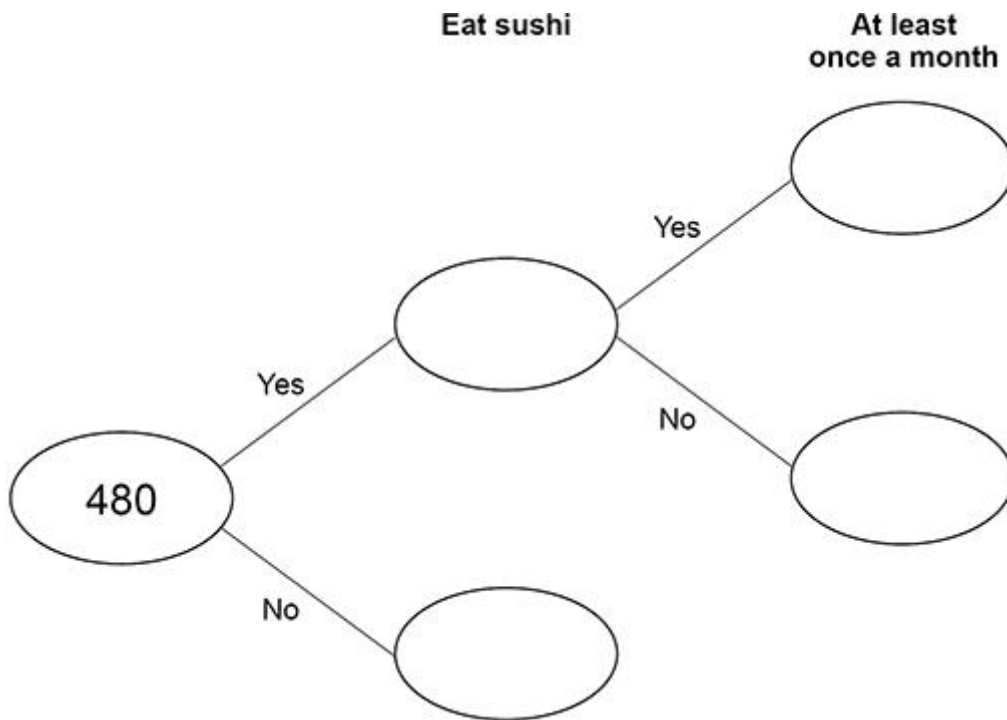

(Total 4 marks)

Q2.

Some students were asked about their daily exercise.

- (a) 12 **more** students answered Yes than answered No.

Complete the frequency tree.

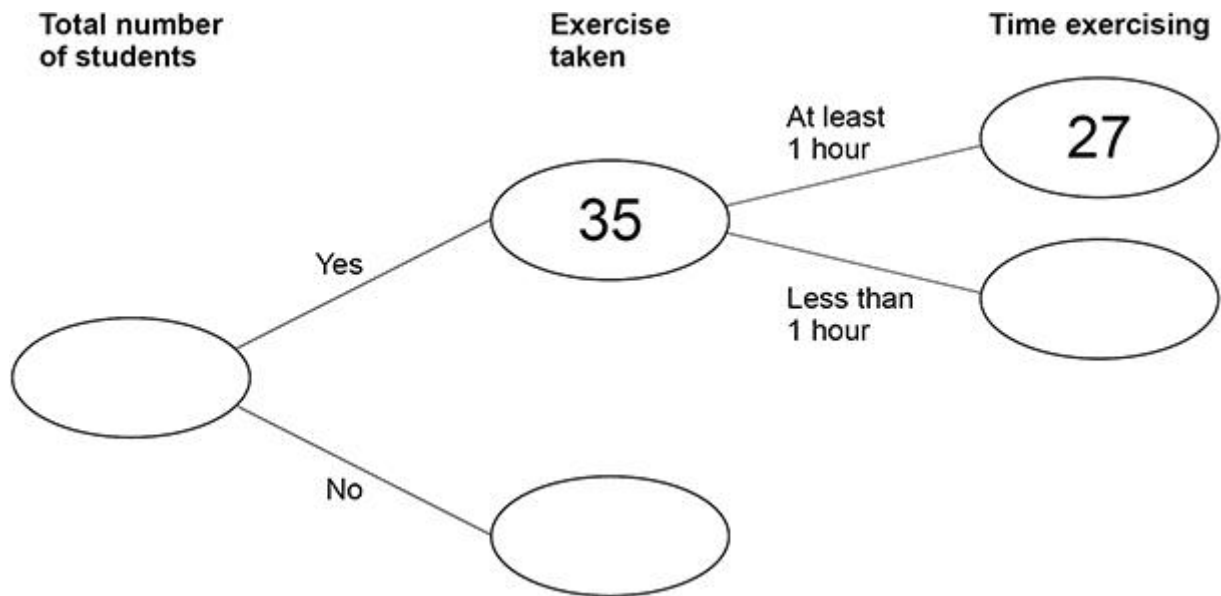

(3)

- (b) One of the 35 students who answered Yes is chosen at random.

What is the probability that they exercise for at least 1 hour?

Answer _____

(1)

(Total 4 marks)

Q3.

A sports team played 40 games.
Half were home games and half were away games.

Each game was a win, a draw or a loss.

Of the **home** games, $\frac{2}{5}$ were losses.

Of the **away** games, $\frac{1}{10}$ were wins.

(a) Complete the frequency tree.

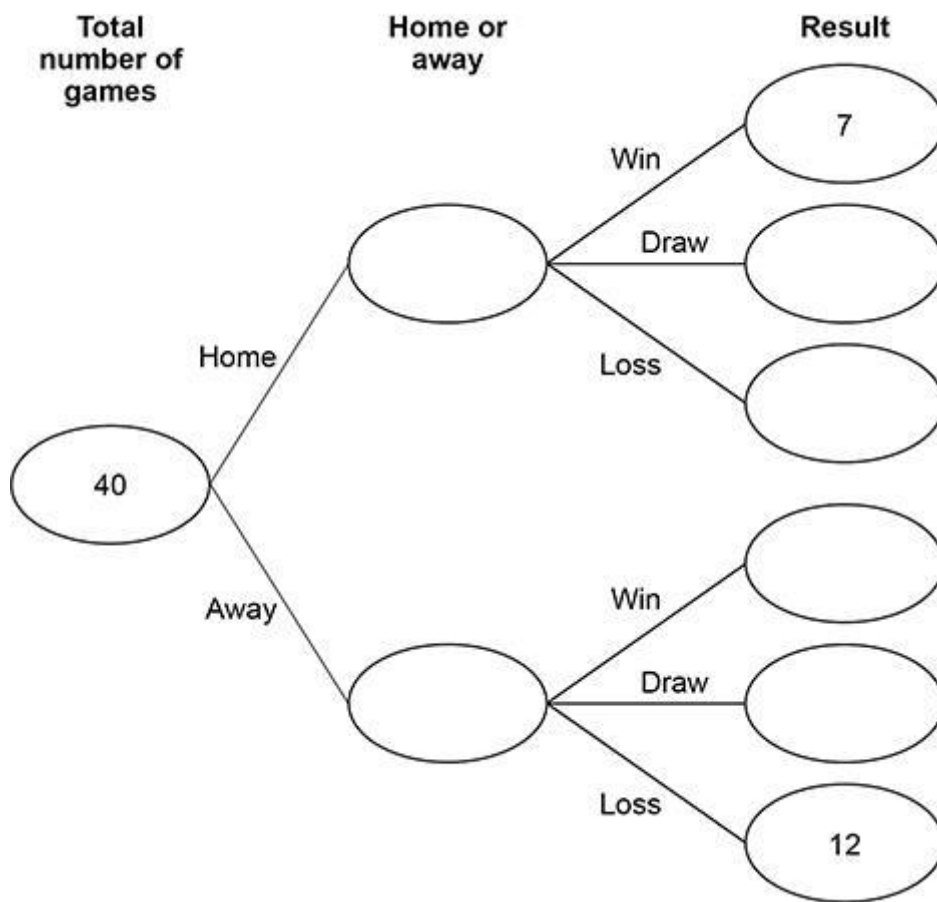

(4)

- (b) The team gets
6 points for a win
3 points for a draw
0 points for a loss.

Work out the **total** number of points that the team got.

Answer _____

(2)
(Total 6 mark

Q4.

500 people started a race.

280 were men and the rest were women.

80% of the men finished the race.

30 women did **not** finish the race.

Complete the frequency tree.

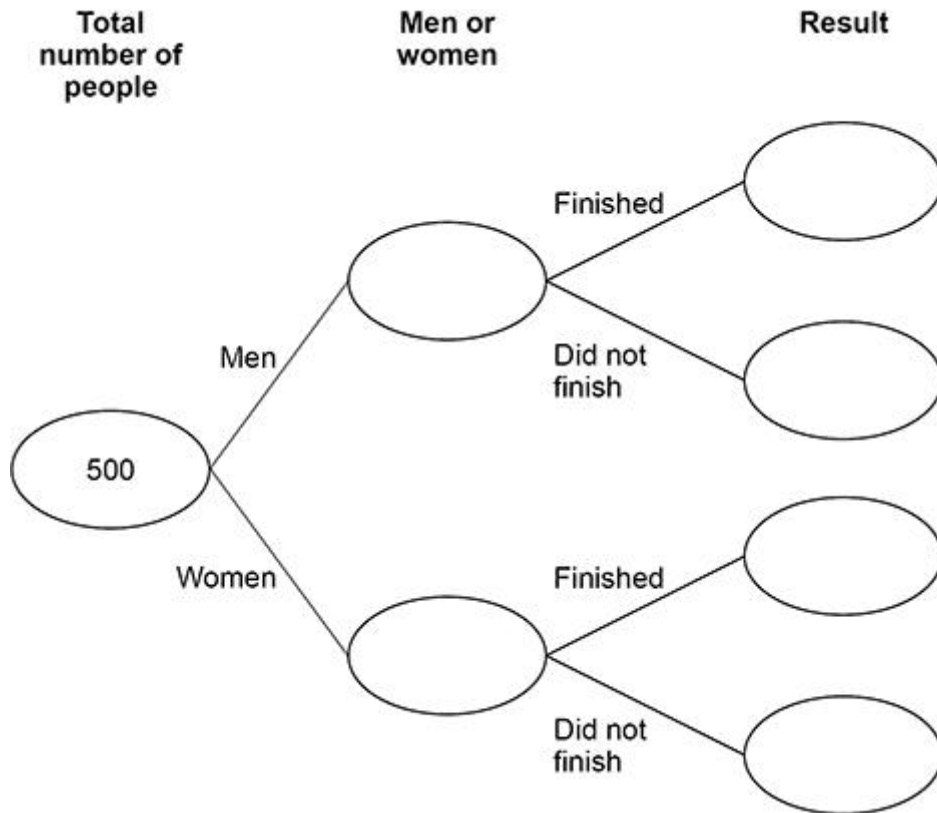

(Total 5 marks)

Q5.

56 customers pay for satellite television.

They **all** have the Basic package for £24.50 per month.

Some also have

the Sports package for £27.50 extra per month

the Movie package for £18 extra per month.

The frequency tree shows the number of customers with each package.

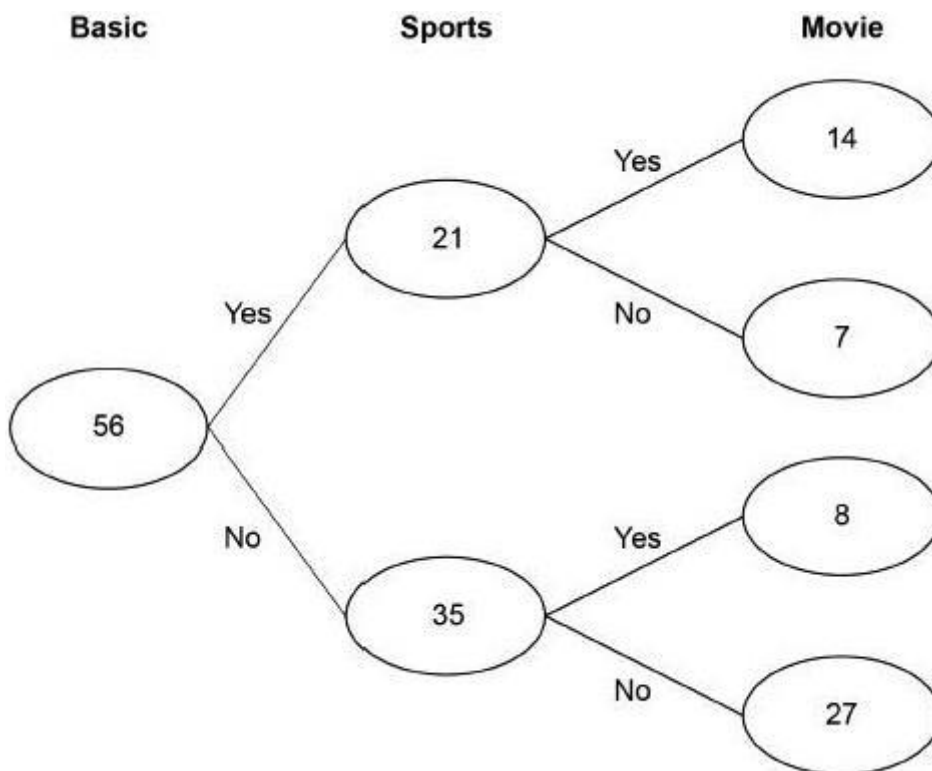

In total, how much per month do the 56 customers pay?

Answer £ _____

(Total 4 marks)

Q6.

A takeaway sells 10-inch pizzas and 12-inch pizzas.

Here is some information about the numbers sold in two weeks.

Week 1

10-inch	512
12-inch	231
Total	743

Week 2

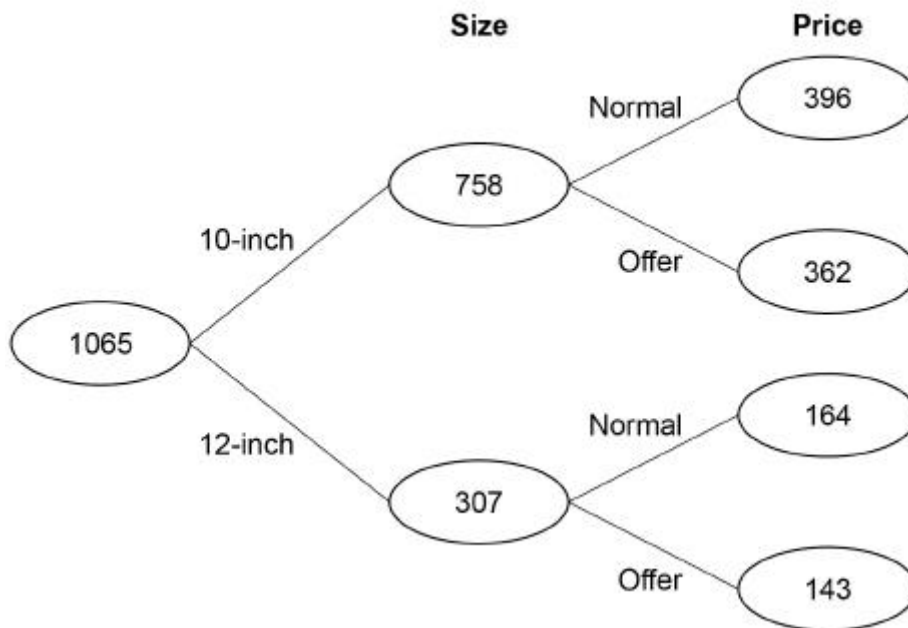

(a) In each week a proportion of the pizzas sold were 10-inch.

In which week was this proportion greater?

Show working to support your answer.

Answer _____

(2)

Q7.

At a cinema, films are shown on Screen 1 and Screen 2

Customers pay full price or child price.

There are three times as many customers in Screen 2 as Screen 1

68 customers paid child price.

Complete the frequency tree.

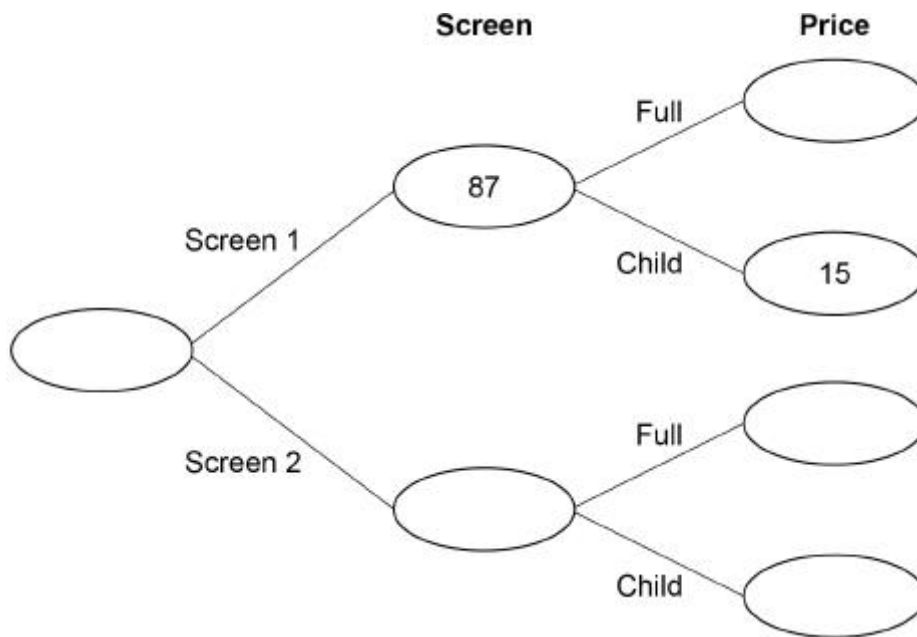

(Total 5 marks)

Q8.

500 people are asked if they drink coffee.

$\frac{9}{10}$ say Yes.

20% of the people who say Yes drink at least three cups each day.

(a) Complete the frequency tree.

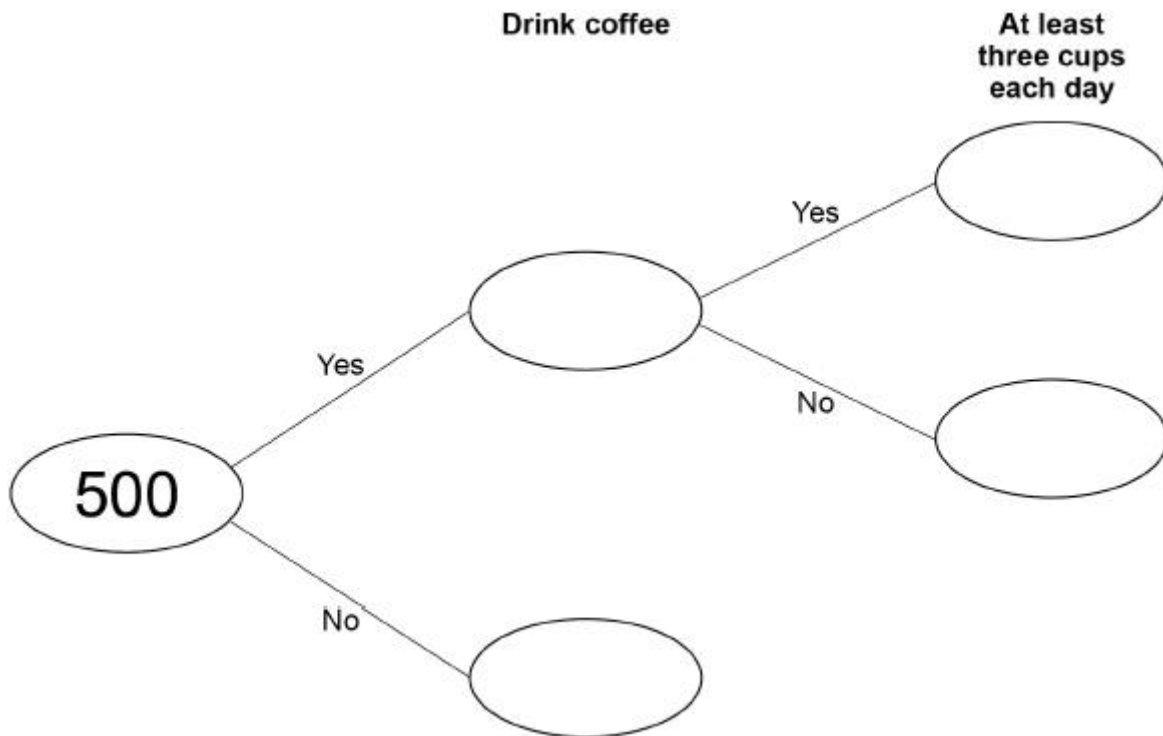

(4)

(b) What fraction of the 500 people drink at least three cups of coffee each day?

Give your answer in its simplest form.

Answer _____

(2)

(Total 6 marks)

Q9.

Two ordinary fair dice are rolled.

(a) Complete the tree diagram.

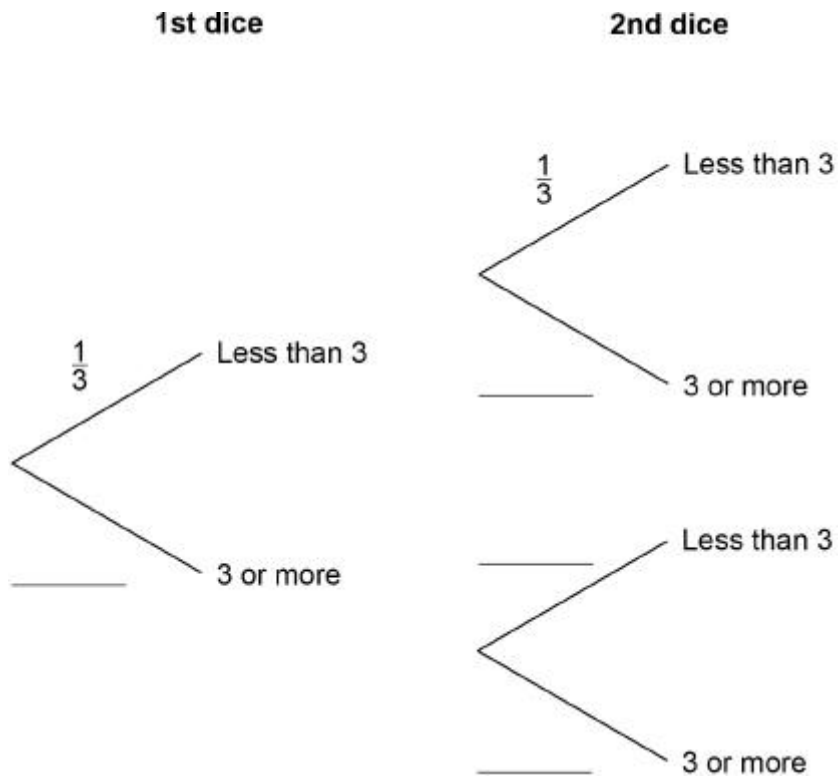

(1)

(b) Work out the probability that **both** dice land on a number less than 3

Answer _____

(1)

(Total 2 marks)

Q11.

Anna plays a game with an ordinary, fair dice.

If she rolls 1 she wins.

If she rolls 2 or 3 she loses.

If she rolls 4, 5 or 6 she rolls again.

When she has to roll again,

if she rolls an odd number she wins

if she rolls an even number she loses.

(a) Complete the tree diagram with the four missing probabilities.

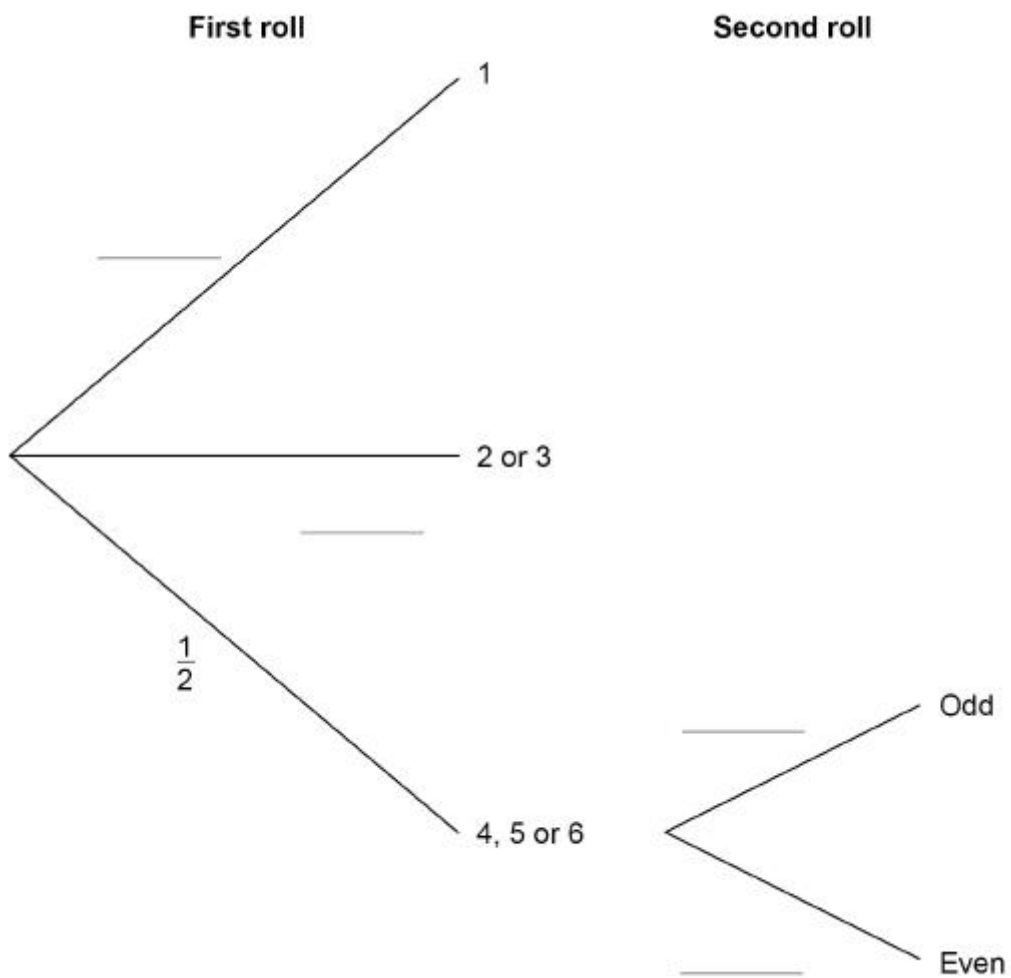

(2)

Venn

Q1.

Circle the expression that means the probability of A and **not** B.

$P(A' \cup B)$

$P(A \cup B')$

$P(A' \cap B)$

$P(A \cap B')$

(Total 1 mark)

Q2.

Here is some information about 120 people who visit a shop.

$\frac{3}{4}$ of the people buy neither a coat nor a dress.

19 people buy a coat.

14 people buy a dress.

Complete this Venn diagram to represent the information.

ξ = 120 people who visit the shop

C = people who buy a coat

D = people who buy a dress

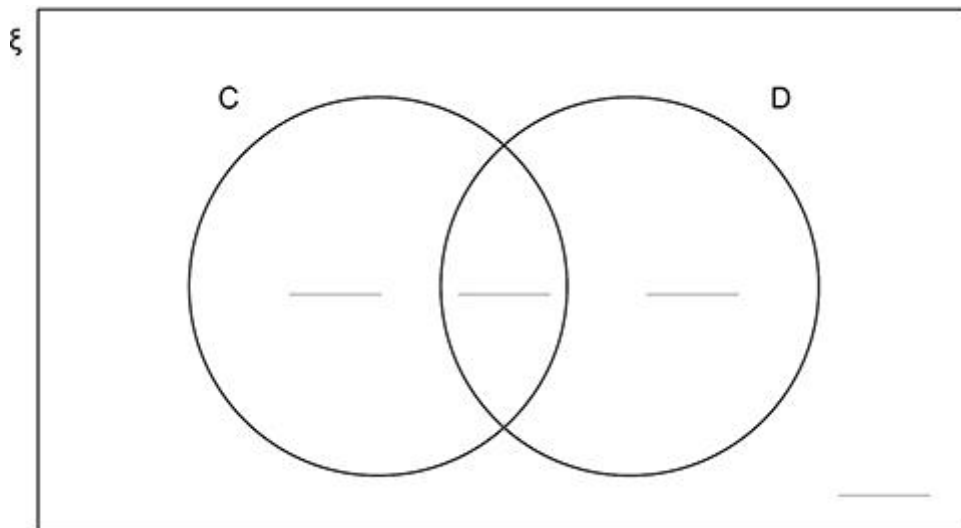

(Total 3 marks)

Q3.

In a group of 98 students

25 study both Art and French

10 study Art but do not study French

41 study French.

Joel draws this Venn diagram to represent the information.

ξ = the group of 98 students

A = the students who study Art

F = the students who study French

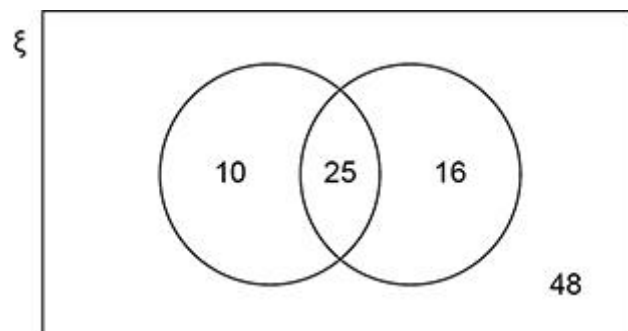

Make **two** criticisms of his diagram.

Criticism 1 _____

Criticism 2 _____

(Total 2 marks)

Q4.

The Venn diagram shows information about a coin collection.

ξ = 150 coins in the collection

T = coins from the 20th century

B = British coins

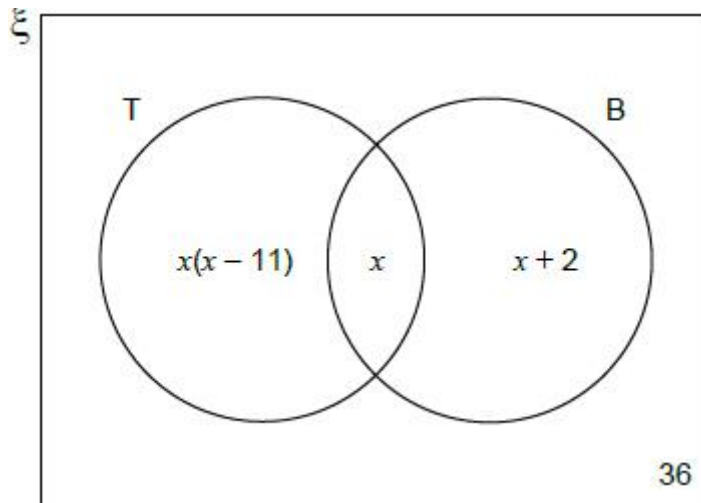

A coin is chosen at random.

It is British.

Work out the probability that it is from the 20th century.

Answer _____

(Total 5 marks)

Q5.

30 pupils are asked about their pets.

The Venn diagram shows some information about their answers.

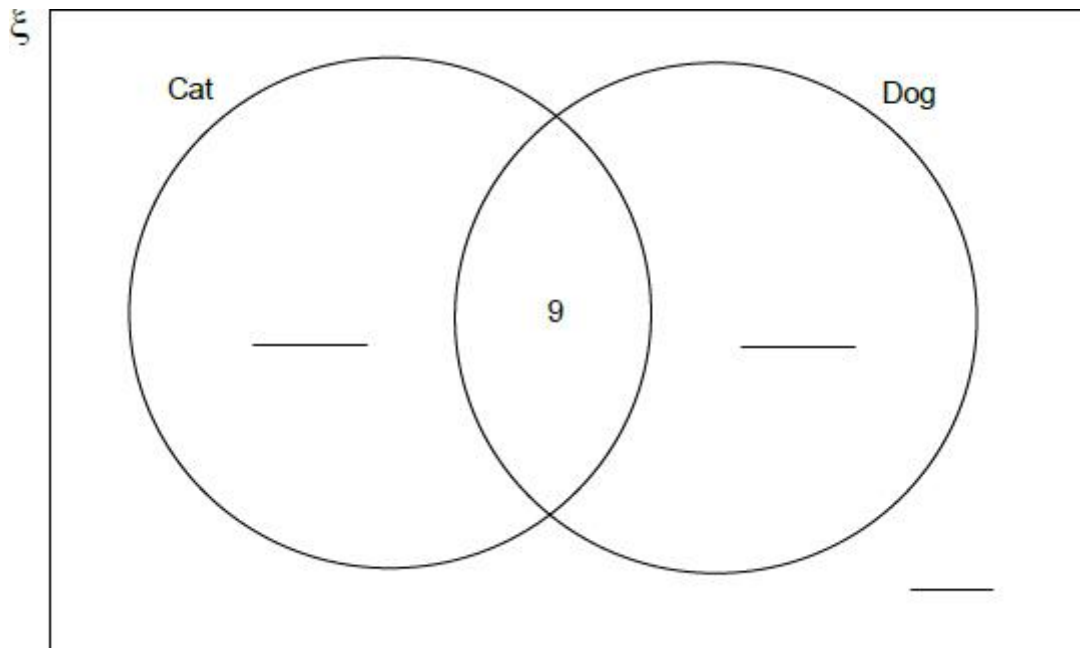

- (a) What does the number 9 on the diagram represent?

(1)

- (b) 16 pupils have a cat and 17 pupils have a dog.

Complete the Venn diagram.

(3)

(Total 4 mark)

Q6.

In the Venn diagram

ξ = 75 students in a Year Group

V = students that play the violin

P = students that play the piano

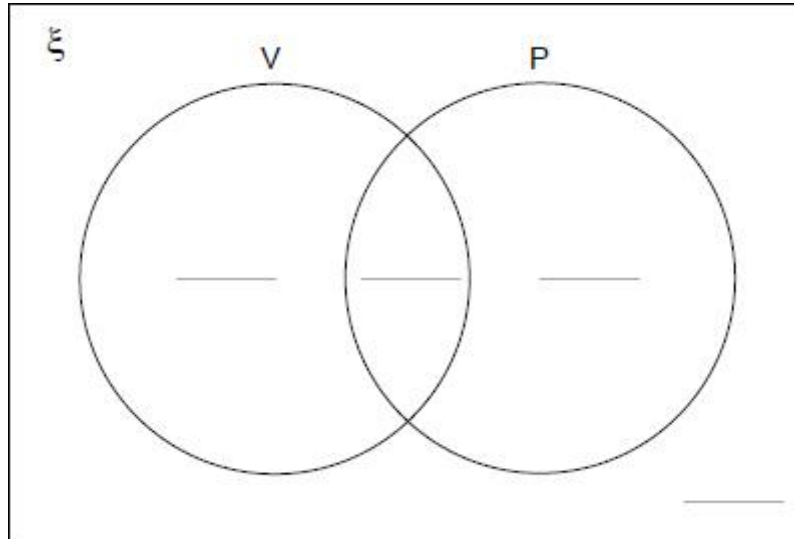

54 students play **only** the violin or **only** the piano.

$\frac{5}{6}$ of these 54 students play **only** the violin.

The number of students that play the violin is four times the number that play the piano.

Complete the Venn diagram.

(Total 5 marks)

Q7.

In the Venn diagram

ξ = 350 students in a college

B = students who take Biology

C = students who take Chemistry

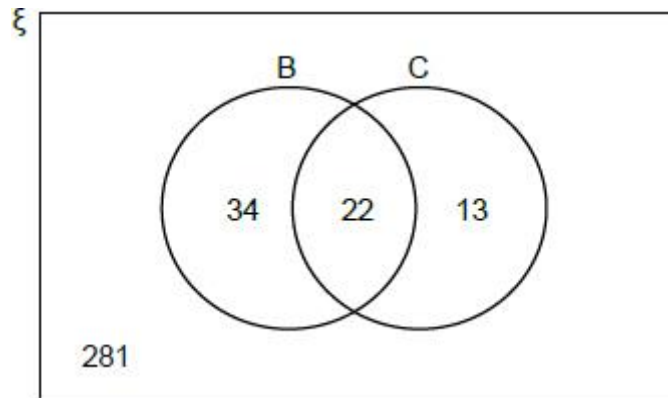

- (a) One student is chosen at random.

Work out the probability that the student takes Biology.

Answer _____

(1)

- (b) One student who takes Chemistry is chosen at random.

Work out the probability that the student **also** takes Biology.

Answer _____

(1)

- (c) In this Venn diagram

ξ = 350 students in the college

IT = students who take IT

BS = students who take Business Studies

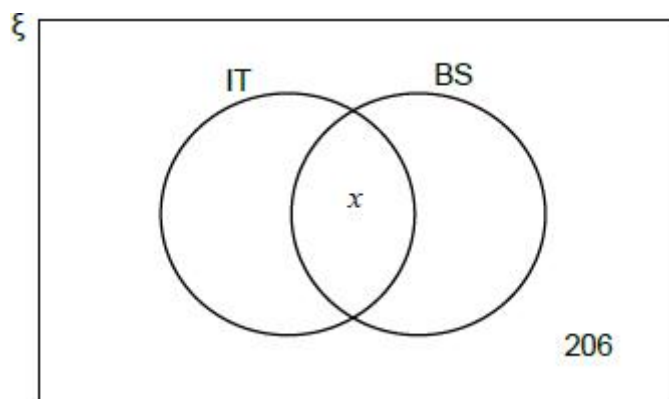

The number of students who take IT and Business Studies is half the number who take IT only.

The number who take Business Studies is double the number who take IT.

Work out the value of x

Answer _____

(3)
(Total 5 marks)

Q8.

100 children are asked if they can ride a bike or swim.

20 can do both, 30 can do neither.

Twice as many can ride a bike as can swim.

Complete the Venn diagram.

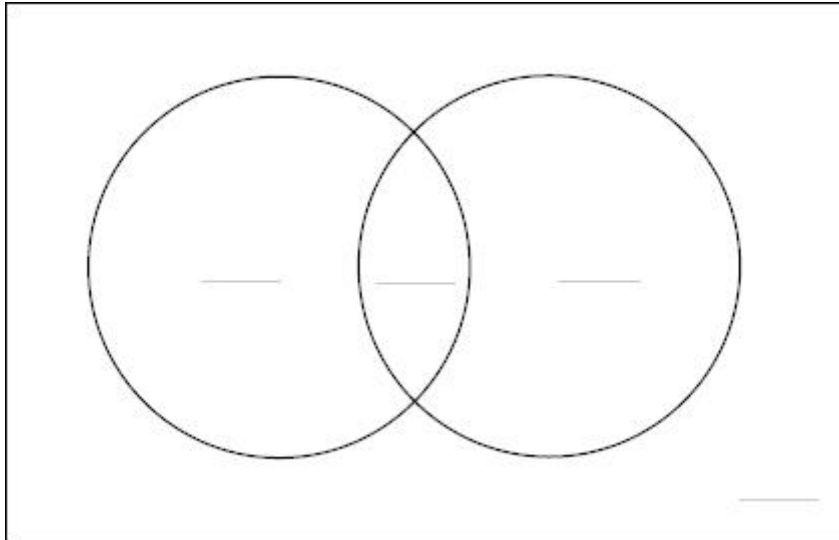

(Total 4 marks)

Q9.

During Year 9 a school runs a trip to the cinema and a trip to bowling.

125 students go to the cinema.

120 students go to bowling.

52 students go to both the cinema and bowling.

47 students do **not** go on either trip.

How many students are there in Year 9?

You may use the Venn diagram to help you.

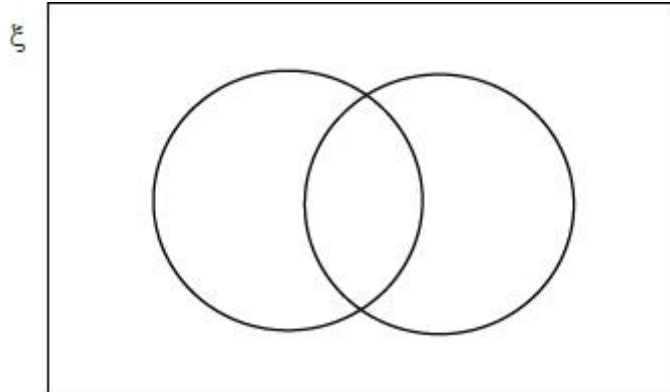

Answer _____

(Total 3 marks)

Q10.

In the Venn diagram

ξ = Whole numbers from 1 to 12 inclusive

M = Multiples of 3

F = Factors of 24

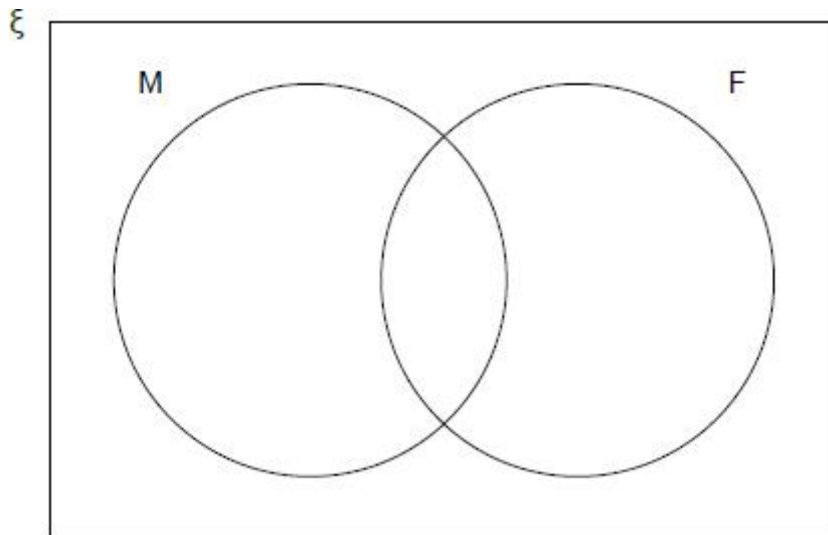

Put the numbers from 1 to 12 in the Venn diagram.

(Total 4 marks)

Q11.

A whole number from 1 to 16 inclusive is picked at random.

ξ = Whole numbers from 1 to 16 inclusive

M = Multiples of 4

F = Factors of 12

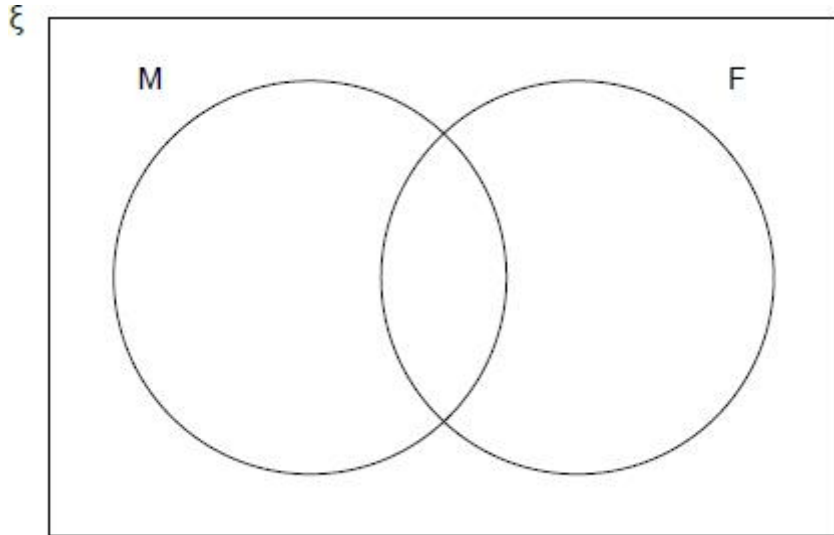

Using the Venn diagram, work out which of these probabilities is greater:

P (the number is a multiple of 4 given it is a factor of 12)

or

P (the number is a factor of 12 given it is a multiple of 4)

You **must** show your working.

Answer _____

(Total 5 marks)

Q12.

At a country park there is a house, a museum and a garden.

The table shows the prices per person to visit the park.

	Price per person
Garden only	Free
House and museum	£12.50
House only	£8
Museum only	£7

One day, 480 people visit the park.

67 visit the garden **only**.

40% visit the house **and** the museum.

$\frac{3}{8}$ visit the house **only**.

The rest visit the museum **only**.

In total, how much do the 480 people pay to visit the park?

You may use the Venn diagram to help you.

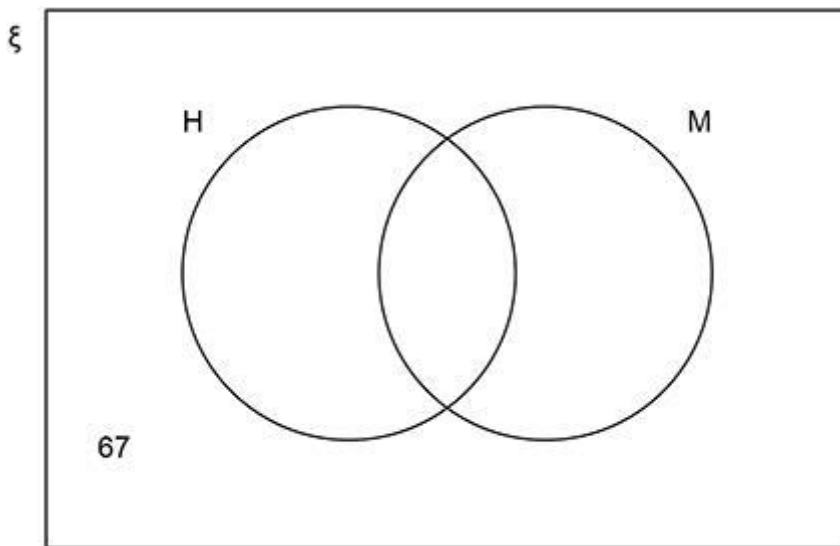

Answer £ _____

(Total 5 marks)

